

Scaffalature serie Alfa

Alfa line shelving | Rayonnages série Alfa

COLORE color | couleur

standard	Grigio RAL 7035
----------	-----------------



Scaffalatura particolarmente adatta ad immagazzinare prodotti medio-leggeri, per magazzini ed archivi. Fissaggio del piano alla fiancata mediante ganci. Dotata di numerosi accessori: cassettiere, contenitori e divisori.

Normativa di sicurezza

Le portate indicate si intendono per carichi uniformemente distribuiti e nella condizione di massima sollecitazione. Dopo il montaggio della scaffalatura è necessario l'allineamento della stessa nel senso della profondità e della lunghezza. Lo spostamento perpendicolare non deve superare 1/200° dell'altezza o lunghezza della scaffalatura. Gli scaffali fissi, caricabili a mano, per i quali l'ultimo piano in alto superi di oltre cinque volte la profondità degli stessi, devono essere fissati a muro o equivalente. Progetti e montaggi devono essere eseguiti da personale esperto e qualificato ed utilizzato in maniera corretta. Le portate delle spalle sono calcolate con il primo piano a 200 mm. da terra, ed i rimanenti a 500 mm. costanti tra loro, ed un minimo di quattro campate collegate fra loro. Prima di ogni installazione accertare l'adeguata consistenza dei solai e pavimenti.

Shelving suitable for storing middle-light products in warehouse and archives. The shelf is fastened on the side by means of hooks. Equipped with many optionals: chests of drawers, containers and partitions.

Safety rules

The capacities are given for uniformly distributed charges in maximal stress condition. After assembling the shelving must be aligned in the sense of its depth and of its length. The perpendicular displacement must not exceed 1/200° of the height or length of the shelving. The fixed shelving, for which the upper shelf is higher more than 5 times than the depth of the same shelving, they must be fastened to the wall. Designs and assembling must be carried out by expert and skilled staff. The capacities are calculated with the first shelf placed at 200 mm from ground, and the other shelves each at 500 mm distance, the length must be at least four modules. Before assembling, check the right resistance of the floor.

Rayonnages pour le stockage de produits moyen-légers pour stock et archives. Fixation du plan au côté à moyen de crochets. Equipée avec plusieurs accessoires: caissons-tiroirs, conteneurs et cloisons.

Normes de sécurité

Les charges indiquées se réfèrent à charges uniformément distribuées dans la condition de maximale sollicitation. Après le montage de l'étagère il faut l'aligner en direction de la profondeur et de la longueur. Le déplacement perpendiculaire ne doit pas dépasser 1/200° de l'hauteur ou longueur de l'étagère. Les rayonnages fixes, chargement manuel, où le dernier étage doit dépasser plus de cinq fois la profondeur, doivent être fixées au mur, ou pareille. Projets et assemblages doivent être fait par personnel expert et qualifié. Les portées sont calculées avec le premier étage à 200 mm de terre et les autres à 500 mm chaque, et aussi au moins 4 modules unies entre eux. Avant de monter, vérifier la tenue des plancher et sol.



Kit Alfa base
Alfa base kit | Kit Alfa module de départ



Kit Alfa aggiuntivo
Additional alpha kit | Kit Alfa module suivant

KIT COMPLETI

complete kits / kit Alfa complet

				PIANO PROF. 300	PIANO PROF. 400	PIANO PROF. 500	PIANO PROF. 600
	elemento	altezza	numero piani	articolo	articolo	articolo	articolo
piano lunghezza 770 mm	base	2000	5	MG6013077KT	MG6014077KT	MG6015077KT	MG6016077KT
	aggiuntivo	2000	5	MG6013077AKT	MG6014077AKT	MG6015077AKT	MG6016077AKT
	base	2500	6	MG6023077KT	MG6024077KT	MG6025077KT	MG6026077KT
	aggiuntivo	2500	6	MG6023077AKT	MG6024077AKT	MG6025077AKT	MG6026077AKT
piano lunghezza 870 mm	base	2000	5	MG6013087KT	MG6014087KT	MG6015087KT	MG6016087KT
	aggiuntivo	2000	5	MG6013087AKT	MG6014087AKT	MG6015087AKT	MG6016087AKT
	base	2500	6	MG6023087KT	MG6024087KT	MG6025087KT	MG6026087KT
	aggiuntivo	2500	6	MG6023087AKT	MG6024087AKT	MG6025087AKT	MG6026087AKT
piano lunghezza 970 mm	base	2000	5	MG6013097KT	MG6014097KT	MG6015097KT	MG6016097KT
	aggiuntivo	2000	5	MG6013097AKT	MG6014097AKT	MG6015097AKT	MG6016097AKT
	base	2500	6	MG6023097KT	MG6024097KT	MG6025097KT	MG6026097KT
	aggiuntivo	2500	6	MG6023097AKT	MG6024097AKT	MG6025097AKT	MG6026097AKT
piano lunghezza 1170 mm	base	2000	5	MG60130117KT	MG60140117KT	MG60150117KT	MG60160117KT
	aggiuntivo	2000	5	MG60130117AKT	MG60140117AKT	MG60150117AKT	MG60160117AKT
	base	2500	6	MG60230117KT	MG60240117KT	MG60250117KT	MG60260117KT
	aggiuntivo	2500	6	MG60230117AKT	MG60240117AKT	MG60250117AKT	MG60260117AKT



FIANCATE sides / echelles		articolo	dimensioni mm
	Componibili, comprese di piedino in gomma e traverse di collegamento. Modular sides equipped with rubber foot and connection crossbars. Éléments équipés avec pied en caoutchouc et barres de connexion	MG 601/30	2000x300
		MG 601/40	2000x400
		MG 601/50	2000x500
		MG 601/60	2000x600
		MG 602/30	2500x300
		MG 602/40	2500x400
		MG 602/50	2500x500
		MG 602/60	2500x600
		MG 603/30	3000x300
		MG 603/40	3000x400
		MG 603/50	3000x500
		MG 603/60	3000x600

FIANCATE PANNELLATE sides with panels / echelles avec panneaux		articolo	dimensioni mm
	Rivestite con pannello metallico. Sides covered with metal panel. Couvertes avec panneau métallique.	MG 621/30	2000x300
		MG 621/40	2000x400
		MG 621/50	2000x500
		MG 621/60	2000x600
		MG 622/30	2500x300
		MG 622/40	2500x400
		MG 622/50	2500x500
		MG 622/60	2500x600
		MG 623/30	3000x300
		MG 623/40	3000x400
		MG 623/50	3000x500
		MG 623/60	3000x600

RETRI SCAFFALE shelving's back / derrière rayonnage		articolo	dimensioni mm
	Agganciabili sulle asole delle fiancate. Can be connected on slides'holes. Accrochables sur les trous des côtés.	MG 6251	870x2000
		MG 6252	970x2000
		MG 6253	1170x2000
		MG 6254	870x2500
		MG 6255	970x2500
		MG 6256	1170x2500

PIANI shelves / plans		articolo	dimensioni mm	portata kg
	Le portate sono intese per carichi uniformemente distribuiti. Piani completi di ganci. Capacities are given for uniformly distributed charges. Shelves equipped with hooks. Charges indiquées pour poids uniformément distribués. Plans avec crochets.	MG 604/30	770x300	90
		MG 604/40	770x400 (1R)	135
		MG 604/50	770x500 (1R)	135
		MG 604/60	770x600 (2R)	160
		MG 605/30	870x300	80
		MG 605/40	870x400 (1R)	120
		MG 605/50	870x500 (1R)	120
		MG 605/60	870x600 (2R)	140
		MG 609/30	970x300	60
		MG 609/40	970x400 (1R)	110
		MG 609/50	970x500 (1R)	110
		MG 609/60	970x600 (2R)	135
		MG 611/30	1170x300	55
		MG 611/40	1170x400 (1R)	90
		MG 611/50	1170x500 (1R)	90
		MG 611/60	1170x600 (2R)	110

CONTENITORI containers / conteneurs		articolo	dimensioni mm
	Composti da sponda anteriore e posteriore, 4 divisori, piano. Consisting of front and back edge, 4 partitions, shelf. Se composent par bord antérieur et postérieur, 4 cloisons, plan.	MG 606/30	970x300
		MG 606/40	970x400
		MG 606/50	970x500
		MG 606/60	970x600
		MG 612/30	1170x300
		MG 612/40	1170x400
		MG 612/50	1170x500
		MG 612/60	1170x600
		MG 618	Divis. 300
		MG 607	Divis. 400
		MG 613	Divis. 500
		MG 617	Divis. 600

SEPARATORI PER PIANI divisions / séparateurs		articolo	dimensioni mm
	Separatori per piani. Divisions for shelves. Séparateurs pour plans.	MG 608/30	300x280
		MG 608/40	400x280
		MG 608/50	500x280
		MG 608/60	600x280

ANTE A BATTENTE swing doors / porte battante		articolo	dimensioni mm
	Coppia ante a battente per chiusura h. 970x2000 mm. Pair of swing doors for closing H. 970x2000 mm. Porte battant	MG 620/40 prof. 400	
		MG 620/50 prof. 500	
		MG 620/60 prof. 600	

CROCIERE steel profiles / croisillons		articolo	dimensioni mm
	Profili in acciaio da applicare al bordo posteriore delle fiancate in alternativa ai retri scaffale, servono a mantenere le caratteristiche di stabilità e robustezza della scaffalatura. Steel profile to connect to the back edge of the sides or back walls, they keep the shelving steady and sturdy. Profils en acier à monter sur le bord postérieur des echelles en alternative aux parois postérieures, ils gardent les caractéristiques de stabilité et solidité de l'étagère.	MG 609CR	

ACCESSORI accessories / accessoires		articolo	dimensioni mm
	Staffa per il fissaggio al muro. Stirrup for wall fastening. Étrier pour la fixation au mur.	MG 600 M	
	Staffa per unire coppia di montanti. Stirrup to join couple of uprights. Étrier pour unir couple de montants.	MG 600 C	
	Perno regolabile per il fissaggio al soffitto. Adjustable pivot for ceiling fastening. Pivot réglable pour la fixation au plafond.	MG 600 P	
	Gancio zincato per piano. Galvanized hook each shelf. Crochet galvanisé pour plan.	MG 612	
	Staffa per montaggio piani ad angolo. Assembly stirrups for corner shelves Accoupleur pour assemblage tablette coin	MG 600 S	

Scaffalature serie Beta

Beta line shelving | Rayonnages série Beta

Scaffalatura realizzata in lamiera zincata a freddo, con lo scopo di risolvere i problemi dello stoccaggio medio e leggero e con la possibilità di realizzare anche strutture a passerelle. Caratteristiche importanti della serie BETA sono: velocità di montaggio, stabilità, portata. L'assemblaggio dei vari componenti avviene ad incastro, ed una vasta gamma di accessori permette di trovare la soluzione adatta alle proprie esigenze. I componenti vengono forniti smontati.

La scaffalatura BETA viene proposta in due versioni: BETA 1 e BETA 2, ciascuna con differenti capacità di portata offrendo quindi una maggiore possibilità di scelta per soddisfare le specifiche esigenze di ciascuno. Per il loro assemblaggio seguire le normative di sicurezza.

Normativa di sicurezza

Prima di ogni installazione dev'essere accertata l'adeguata consistenza dei solai e del pavimento. L'assemblaggio delle scaffalature deve essere eseguito da personale specializzato, rispettando le normative di sicurezza e prestando particolare attenzione alla chiusura dei dispositivi antigianciamento. Dopo il montaggio è necessario allineare la scaffalatura nel senso della profondità e della lunghezza. Fiancate con altezza maggiore di 5 volte la profondità, devono essere tassellate a terra. È vietato l'utilizzo di scaffalature monofronte con altezze maggiori di 8 volte la profondità. Scaffalature con meno di 4 campate o con distanza dei piani maggiore di 700 mm, o con fiancate di altezza maggiore di 3000 mm devono essere controventate e tassellate a terra. Le strutture Beta1 e Beta2 sono destinate a operazioni di picking manuale, non è previsto quindi l'immagazzinaggio con carrelli elevatori o transpallets lungo i corridoi. Le portate delle fiancate sono state calcolate con il primo livello da terra a mm 700, ed i livelli successivi a 500 mm costanti fra loro, con un minimo di 4 campate tassellate a terra. Le portate dei piani si intendono con carico uniformemente distribuito (C.U.D.) e con freccia massima di 1/200 della lunghezza del piano. La MG srl declina ogni responsabilità per danni o incidenti provocati da un errato utilizzo o montaggio delle scaffalature e degli accessori.

Shelving made of cold galvanised sheet metal. They are used to solve the problems connected with light storage and in order to build loft structures. The main characteristics of the line BETA are: quick assembling, stability,

capacity. The different parts are jointed, and a wide range of optionals allows to find the right solution for any exigencies. The parts are delivered disassembled. Shelving line BETA is proposed in two versions: BETA 1 and BETA 2 with different loading capacities and thus with a wider range of choice in order to satisfy all various requests. Follow security rules for assembling.

Safety rules

Before assembling, check the due resistance of the floor. Design and assembling must be carried out by specialized staff, respecting safety rules and paying the utmost attention in ensuring the anti-unhooking mechanism. After assembling, the shelving must be aligned in the sense of its depth and of its length.

Shelving higher than 5 times the base must be fastened to the ground. It is not possible to assemble single-sided shelving high more than 8 times the depth. Shelving composition with less than 3 spans or with shelves distance more than 700 mm or with height more than 3000 mm must be fastened to the ground.

Shelving Beta1 and Beta2 are intended for manual picking, they are not suited for store handling with forklift or transpallet on the corridors. The capacities are intended with first level at 700 mm, and shelving distance of 500 mm, with minimum 4 spans fastened to the ground. The capacities are intended for uniformly distributed charges (CUD) and with perpendicular displacement not exceeding 1/200 of the length of the shelving. MG srl is not responsible for any damage or in-

cident occurred because of misuse or incorrect assembling of shelving and accessories.

Rayonnages réalisées en tôle galvanisée à froid. Projetée pour la solution de problèmes de stockage léger et pour donner la possibilité de réaliser structures à mezzanine.

Les caractéristiques importantes de la série BETA sont: rapidité de montage, solidité, charge. Le montage des éléments est à encastrement, et beaucoup d'accessoires permettent de trouver la solution meilleure pour toutes exigences. Les éléments sont livrés démontés. Le rayonnage BETA est proposé en deux versions: BETA 1 et BETA 2 avec différentes capacités de portée, donc une plus grande possibilité de choix pour satisfaire les exigences spécifiques de chaque client.

Normes de sécurité

Avant de monter, vérifier la tenue des plancher et sol. Le montage doit être assuré par du personnel spécialisé, en respectant les normes de sécurité et en veillant en particulier au verrouillage des dispositifs antidécrochage. Après le montage de l'étagère il faut l'aligner en direction de la profondeur et de la longueur. Les parois d'une hauteur supérieure à 5 fois la profondeur doivent être fixées au sol à l'aide de chevilles.

L'emploi de rayonnages monofront de hauteurs supérieures à 8 fois la profondeur est interdit. Les rayonnages de moins de 4 travées ou d'une distance entre les étagères de plus de 700 mm, ou avec des épaulements d'une hauteur de plus de 3000 mm, doivent être fixés au sol. Structures avec moins de 4 modules ou

distances supérieures à 700 mm, ou avec des épaulements d'une hauteur de plus de 3000 mm doivent être fixés au sol. Les cadres Beta 1 et Beta 2 sont destinés à des opérations de prélèvement manuel, le stockage par chariots élévateurs ou transpallets n'est donc pas prévu dans les couloirs. Les charges sont calculées avec le premier étage à 700 mm de terre et les autres à 500 mm chaque, et aussi au moins 4 modules unies entre eux. Les charges indiquées se réfèrent à charges uniformément distribuées dans la condition de maximale sollicitation. MG srl décline toute responsabilité en cas de dommages ou accidents survenus suite à une utilisation mauvaise ou un mauvais montage des rayonnages et des accessoires.



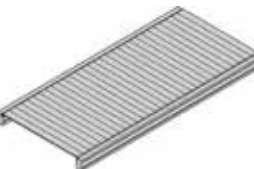

FIANCATE BETA1 sides / échelles		articolo	articolo smontato	dimensioni mm	portata kg
	Complete di montanti, distanziali, diagonali e piedini in gomma. <i>Sides equipped with uprights, spacing, bars, crossbars and rubber feet. Équipées avec montants, barres, axes et pieds en caoutchouc.</i>	MG 6713	MG6713S	1972x320	1500
		MG 6714	MG 6714S	2500x320	1500
		MG 6715	MG 6715S	3028x320	1500
		MG 6716	MG 6716S	1972x400	1500
		MG 6717	MG 6717S	2500x400	1500
		MG 6718	MG 6718S	3028x400	1500
		MG 6719	MG 6719S	1972x500	1500
		MG 6720	MG 6720S	2500x500	1500
		MG 6721	MG 6721S	3028x500	1500
		MG 6722	MG 6722S	1972x600	1500
		MG 6723	MG 6723S	2500x600	1500
		MG 6724	MG 6724S	3028x600	1500

FIANCATE BETA2 sides / échelles		articolo	articolo smontato	dimensioni mm	portata kg
	Complete di montanti, distanziali, diagonali e piedini in acciaio. <i>Sides equipped with uprights, spacing, bars, crossbars and steel feet. Équipées avec montants, barres, axes et pieds en tôle.</i>	MG 6725	MG 6725S	1972x320	2000
		MG 6726	MG 6726S	2500x320	2000
		MG 6727	MG 6727S	3028x320	2000
		MG 6728	MG 6728S	3424x320	2000
		MG 6729	MG 6729S	1972x400	2000
		MG 6730	MG 6730S	2500x400	2000
		MG 6731	MG 6731S	3028x400	2000
		MG 6732	MG 6732S	3424x400	2000
		MG 6733	MG 6733S	1972x500	2000
		MG 6734	MG 6734S	2500x500	2000
		MG 6735	MG 6735S	3028x500	2000
		MG 6736	MG 6736S	3424x500	2000
		MG 6737	MG 6737S	1972x600	2000
		MG 6738	MG 6738S	2500x600	2000
		MG 6739	MG 6739S	3028x600	2000
		MG 6740	MG 6740S	3424x600	2000

PIANI BETA1 shelves / plans		articolo	dimensioni mm	portata kg
	Complet di n°2 correnti h. 47 mm e pianetti h. 12 mm. <i>Shelves equipped with 2 bars h. 47 mm and shelves h. 12 mm. Équipées avec n° 2 axes h. 47 mm et plans h. 12 mm.</i>	MG 6801	900x320	280
		MG 6802	900x400	235
		MG 6803	900x500	180
		MG 6804	900x600	150
		MG 6805	1200x320	200
		MG 6806	1200x400	200
		MG 6807	1200x500	200
		MG 6808	1200x600	200
		MG 6809	1500x320	140
		MG 6810	1500x400	140
		MG 6811	1500x500	140
		MG 6812	1500x600	140

PIANI BETA2 shelves / plans		articolo	dimensioni mm	portata kg
	Complet di n°2 correnti h. 47 mm e pianetti h. 12 mm. <i>Shelves equipped with 2 bars h. 47 mm and shelves h. 12 mm. Équipées avec n° 2 axes h. 47 mm et plans h. 12 mm.</i>	MG 7001	900x320	300
		MG 7002	900x400	230
		MG 7003	900x500	180
		MG 7004	900x600	150
		MG 7005	1200x320	270
		MG 7006	1200x400	270
		MG 7007	1200x500	260
		MG 7008	1200x600	210
		MG 7009	1500x320	170
		MG 7010	1500x400	170
		MG 7011	1500x500	170
		MG 7012	1500x600	170

TAMPONAMENTO LATERALE slide covering / couverture latéral		articolo	dimensioni mm
	Compreso di profilo superiore ed inferiore e di ganci per il fissaggio. <i>Equipped with upper and lower profile and fastening hooks. Équipées avec profil supérieur et inférieur et de crochets pour la fixation.</i>	MG 6820	1972x320
		MG 6821	1972x400
		MG 6822	1972x500
		MG 6823	1972x600
		MG 6824	2500x320
		MG 6825	2500x400
		MG 6826	2500x500
		MG 6827	2500x600
		MG 6828	3028x320
		MG 6829	3028x400
		MG 6830	3028x500
		MG 6831	3028x600
		MG 7020	3424x320
		MG 7021	3424x400
		MG 7022	3424x500
		MG 7023	3424x600

TAMPONAMENTO POSTERIORE back covering / couverture postérieur		articolo	dimensioni mm
	Compreso di profilo superiore ed inferiore e di ganci per il fissaggio. <i>Equipped with upper and lower profile and fastening hooks. Équipées avec profil supérieur et inférieur et de crochets pour la fixation.</i>	MG 6832	1972x900
		MG 6833	1972x1200
		MG 6834	2500x900
		MG 6835	2500x1200
		MG 6836	3028x900
		MG 6837	3028x1200
		MG 7024	1972x1500
		MG 7025	2500x1500
		MG 7026	3028x1500
		MG 7027	3424x1500
		MG 7028	3424x1200
		MG 7029	3424x900

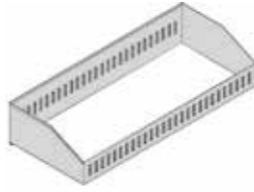
CONTENITORI containers / conteneurs		articolo	dimensioni mm
	Composti da sponda anteriore h. 100 mm, sponda posteriore h. 200 mm, 2 divisori trapezoidali di unione. Escluso piano. <i>Containers made up of: front edge H 100 mm, rear edge H 200 mm, 2 trapezoidal dividers for fastening the edges. Shelf not included. Composé par un rebord antérieur H 100 mm. Postérieur H 200 mm, 02 cloisons trapézoïdal. Etagère exclu.</i>	MG 6880	900x320
		MG 6881	900x400
		MG 6882	900x500
		MG 6883	900x600
		MG 6884	1200x320
		MG 6885	1200x400
		MG 6886	1200x500
		MG 6887	1200x600
		MG 6920	1500x320
		MG 6921	1500x400
		MG 6922	1500x500
		MG 6923	1500x600

DIVISORI partitions / claisons		articolo	dimensioni mm
	Divisori trapezoidali per contenitori. <i>Trapezoidal partitions for containers. Claisons trapezoidals pour conteneurs</i>	MG 6890	320
		MG 6891	400
		MG 6892	500
		MG 6893	600

scaffalature *Shelving* | *Rayonnages*

CONTENITORI A VASCA

tub containers / conteneurs a bassin

		articolo	dimensioni mm
	Composti da contenitori a vasca, 2 correnti, 2 divisori laterali. <i>Consisting of front and back edge, 2 sides, shelf</i> <i>Équipées avec bord antérieur et postérieur, 2 côtés, plan</i>	MG 6860	900x320
		MG 6861	900x400
		MG 6862	900x500
		MG 6863	900x600
		MG 6864	1200x320
		MG 6865	1200x400
		MG 6866	1200x500
		MG 6867	1200x600
		MG 6924	1500x320
		MG 6925	1500x400
MG 6926	1500x500		
MG 6927	1500x600		

DIVISORI PER CONTENITORI A VASCA

partitions / séparateur

		articolo	dimensioni mm
	Divisori per contenitori a vasca. <i>Partition for tub containers.</i> <i>Séparateur pour conteneurs a bassin.</i>	MG 6868	320
		MG 6869	400
		MG 6870	500
		MG 6871	600

SEPARATORE PER PIANI *shelf division / séparateur*

		articolo	dimensioni mm
	Separatore per piani. <i>Division for shelves.</i> <i>Séparateur pour plans.</i>	MG 6910	320
		MG 6911	400
		MG 6912	500
		MG 6913	600

DISTANZIALI PORTATUBI

pipe-holder spacing bar / barres porte-tube

		articolo	dimensioni mm	numero asole
	Applicati ai montanti sostengono i tubi portagruce. Con asole portatubi. <i>Assembled on the uprights, they support dress-hanger pipes. With pipe-holder holes.</i> <i>Assemblées aux montants soutiennent les barres porte-cintres.</i>	MG 6839	300	3 asole
		MG 6840	400	5 asole
		MG 6841	500	7 asole
		MG 6842	600	9 asole

TUBI DA APPLICARE SUI DISTANZIALI *pipes / tubi*

		articolo	dimensioni mm
	Si applicano sui distanziali, nel caso di utilizzo dei tubi portagruce, è necessario rinforzare lo scaffale con tre coppie di correnti distribuiti in altezza. <i>Pipes to be assembled on spacing bars - In case of use of dress-hanger pipes, the shelving must be strengthened with three couple of bars placed in the sense of the height.</i> <i>Barres a monter sur les entresoisés, en case emplie des tubes portecintres, il faut renforcer l'étagère avec trois couples d'axes montées en hauteur.</i>	MG 6850	900
		MG 6851	1200
		MG 6849	1500

CORRENTE TUBOLARE

tubular bar / longerons entubolare

		articolo	dimensioni mm	portata per coppia con C.U.D <i>Load capacity for a pair (evenly distributed load)</i> <i>Charge pour a couple (poids uniformément distribué)</i>
	Da applicare sulle fiancate, utilizzabile per portagomme. <i>To be assembled on the sides, can be used as a tyre-holder.</i> <i>A monter sur les ecuelles, à employer aussi comme porte-pneus.</i>	MG 6852	900	300 kg.
		MG 6853	1200	210 kg.
		MG 6857	1500	120 kg.

STAFFA PER ACCOPPIAMENTO MONTANTI

stirrup / étrier

	Staffa per accoppiamento montanti. <i>Stirrup for uprights couplin.</i> <i>Étrier pour couplage montant.</i>	MG 6855
---	---	---------

STAFFA PER FISSAGGIO A MURO

stirrup / étrier



	Staffa per fissaggio a muro. <i>Stirrup for wall fastening.</i> <i>Étrier pour fixation au mur.</i>	MG 6856
---	--	---------

ETICHETTA IN PLASTICA

plastic labels / étiquette en plastique

	Completa di cartoncino e PVC trasparente. <i>Equipped with card and transparent pvc.</i> <i>Avec carte et pvc transparent.</i>	MG 6854
---	--	---------

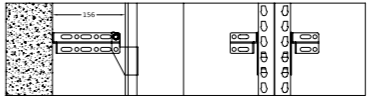
ACCESSORI PER PORTA GOMME *components for tire-holder shelving / accessoires porte pneus*

			
● MG 67006 Base speciale completa <i>Complete special base</i> <i>Pied métal</i>	● MG 67007 Staffa fissaggio a muro 150 mm <i>Wall fastening stirrup 150 mm</i> <i>Accoupleur pour fixation au mur 150 mm</i>	● MG 67400 Distanziatore fissaggio campate 400 mm <i>Aisle fastening spacer mm 400</i> <i>Séparations entre travées</i>	● MG 67016 Particolare anti sganciamento <i>Movement-proof device</i> <i>Goupilles de sécurité</i>



Scaffalature serie Gamma

Gamma line shelving | Rayonnages série Gamma

COLORE CORRENTE tubular bar color | couleur lisse

standard ARANCIO Orange / Orange RAL 2004

FIANCATE sides / côtés

Zincate | galvanized | galvanisée

La scaffalatura GAMMA è un sistema strutturale ad incastro, che garantisce portate elevate ed offre una vasta gamma di componenti. Particolarmente indicata per lo stoccaggio di pallet. È costituita da componenti base ed accessori. Le fiancate sono assemblate con bulloni speciali, il profilo è dotato di asole con passo mm 50. I correnti sono in lamiera scatolata, di diverse sezioni e portate, capaci di offrire specifiche risposte ad ogni esigenza. I pianetti zincati ed altri accessori completano l'offerta di varietà di soluzioni per stoccare varie tipologie di materiali.

Normativa di sicurezza

Le portate indicate si intendono per carichi uniformemente distribuiti e nella condizione di massima sollecitazione. In apposito punto devono essere fissate delle targhette indicanti il carico massimo per piano e per fiancata. Dopo il montaggio della scaffalatura è necessario l'allineamento della stessa nel senso della profondità e della lunghezza.

Gli scaffali devono essere fissati a muro o pavimento. Prima di ogni installazione accertare l'adeguata consistenza dei solai e pavimenti. Progetti e montaggi devono essere eseguiti da personale specializzato, rispettando le normative di sicurezza specificate nel "Manuale di montaggio, uso e manutenzione" e prestando particolare attenzione alla chiusura dei dispositivi antiganciamento. La MG srl declina ogni responsabilità per danni o incidenti provocati da un errato utilizzo o montaggio delle scaffalature e degli accessori.

GAMMA shelving is a structural jointing system, indicated for pallet storing, and offers a wide variety of components. It is composed by main parts and accessories. Sides are assembled with specific bolts; the profile has buttonholes with distance of 50mm height. Bars are of boxed sheet, of various sections and capacities, and offer specific solutions to various requests. Galvanized shelves and various fittings complete the offer for storing different kind of materials.

Safety rules

The capacities are given for uniformly distributed charges in maximal stress condition. Labels indicating the maximal charge for each shelf and for each side must be placed in the right point. After assembling the shelving must be aligned in the sense of its depth and of its length. Before assembling, check the right resistance of the floor. Design and assembling must be done by specialized staff, respecting safety rules and paying the utmost attention in ensuring the anti-unhooking mechanisms. MG srl is not responsible for any damage or incident occurred because of misuse or incorrect assembling of shelving and accessories.

Le rayonnage GAMMA est un système structurel à encastrer, qui garantit des charges élevées et propose une vaste gamme d'éléments. Particulièrement indiqué pour le stockage de palettes. Est constitué par des éléments de base et d'accessoires. Les parois latérales sont assemblées avec des boulons spéciaux, le profil est muni de perforations à pas de 50 mm. Les courants sont en tôle en forme de caisson de différentes sections et portées, afin d'apporter des solutions spécifiques à tous les besoins. Les étagères galvanisées et autres accessoires complètent l'offre de variété de solutions pour stocker plusieurs types de matériel.

Normes de sécurité

Les charges indiquées se réfèrent aux poids uniformément distribués dans la condition de maximale sollicitation.

Dans le point exact doivent être fixées des étiquettes indiquant la charge maximale à chaque étage et côté. Après le montage de l'étagère il faut l'aligner en direction de la profondeur et de la longueur. Avant de monter, vérifier la tenue des plancher et sol. Les projets et montages doivent être confiés à du personnel spécialisé, en respectant les normes de sécurité et en veillant en particulier au verrouillage des dispositifs antidécrochage. MG srl décline toute responsabilité en cas de dommages ou d'accidents survenus suite à une utilisation mauvaise ou un mauvais montage des rayonnages et des accessoires.

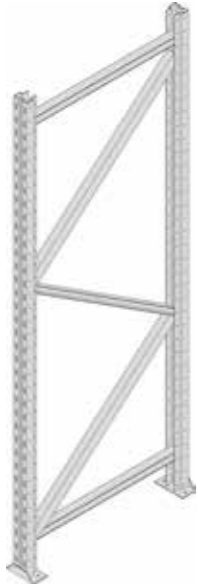

FIANCATE sides / côtés

	articolo	dimensioni mm
 <p>Fiancate zincate. Galvanized sides. Echelles galvanisés.</p>	MG 801N	2025 x 600 x 90
	MG 802N	2025 x 800 x 90
	MG 803N	2025 x 1000 x 90
	MG 804N	2025 x 1200 x 90
	MG 805N	2550 x 600 x 90
	MG 806N	2550 x 800 x 90
	MG 807N	2550 x 1000 x 90
	MG 808N	2550 x 1200 x 90
	MG 809N	3000 x 600 x 90
	MG 810N	3000 x 800 x 90
	MG 811N	3000 x 1000 x 90
	MG 812N	3000 x 1200 x 90
	MG 813N	4050 x 600 x 90
	MG 814N	4050 x 800 x 90
	MG 815N	4050 x 1000 x 90
	MG 816N	4050 x 1200 x 90

PORTATA FIANCATA - 15/10 S235 | Sides load capacity - 15/10 S235 | Charge échelle - 15/10 S235

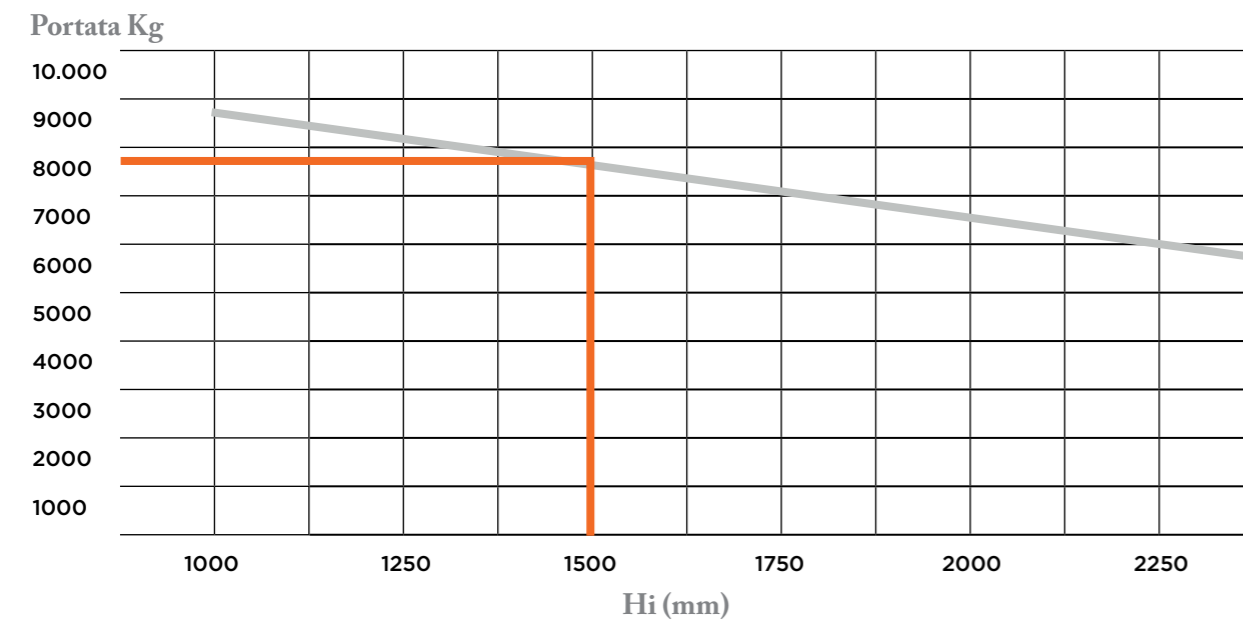

Esempio Example / Exemple

Hi > altezza primo piano da terra
 Hi > Height of the first shelf from the ground
 Hi > Distance du sol de la première tablette

Portata fiancata
 Sides load capacity | Charge échelle
7800 kg.

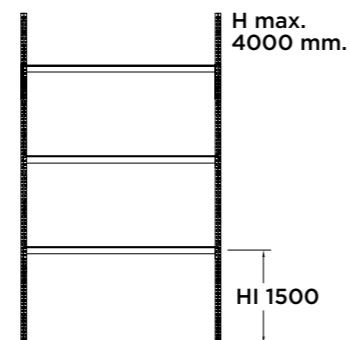

COPPIE CORRENTI
couple of bars / couple lisses

	articolo	sez. P	sez. H	lunghezza	portata kg coppia	portata kg coppia con pianetti
 <p>Coppie correnti. Le portate sono da considerarsi per coppie correnti per carichi uniformemente distribuiti. Colore arancio RAL 2004. Pair of bars. Colour orange RAL 2004. Couple lisses. Couleur orange RAL 2004.</p>	MG 837N	100	40	1350	2800	1000
	MG 838N	100	40	1800	2200	850
	MG 839N	100	40	2250	1900	600
	MG 840N	120	40	1800	3400	2400
	MG 841N	120	40	2250	2800	1990
	MG 842N	120	40	2700	2400	1700

ROMPITRATTA section breaker / traverse

	articolo	profondità fiancata
 <p>Rompitratta, zincati per unire i correnti tra loro. Zinc-coated section breaker. Traverse galvanisés.</p>	MGRT80N	800
	MGRT100N	1000
	MGRT120N	1200

PARACOLPI PROTEZIONE BASE base protection buffer / butoir protection base

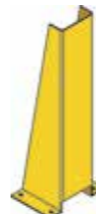
 <p>Paracolpi protezione. 140 x 200 x 250 mm. Base protection buffer. Protection en metal.</p>	MGPC 09
--	---------

PIANETTI ZINCATI shelves / plans

	articolo	dimensioni mm
 <p>Pianetti zincati. Quando si usano i pianetti la portata massima è quella minore fra correnti e pianetti. Zinc coated shelves. When using shelves the maximum load capacity is the lowest one between that of the sides and that of the shelves. Plans galvanisés. Quand il y a des plans galvanisés la charge max est la plus petite indiquée entre lisses et plans.</p>	MG 921	150 x 515 x 25
	MG 922	150 x 712 x 25
	MG 923	150 x 912 x 25
	MG 924	150 x 1112 x 25

