



**Lubrication Solutions from iwis**  
Guide for the correct use of iwis lubricants

**Did you know?**



of chain failures can be prevented  
by **appropriate relubrication**.

## Correct relubrication reduces wear and prolongs chain service life

Regular maintenance and lubrication are essential to ensure low wear and longer chain drive service life.

The operating conditions of the system determine maintenance and lubrication intervals. Scheduled maintenance and lubrication must be **carried out regularly**. Around two thirds of chain failures can be prevented by **suitable relubrication**, so the choice of a suitable (re)lubricant is the most important factor in ensuring **long chain service life**, since the individual links of a chain act as bearings while the constantly oscillating chain is in operation.

Inadequate lubrication and additional contamination can cause a reduction of chain performance by as much as 20%, thereby **reducing service life** more than any other influencing factors.

Our lubricants were **developed especially for and with iwis**, so their ingredients and properties are **optimally suited to the product 'chain'**. Thanks to countless trials on specially developed test rigs and our close collaboration with reputable lubricant manufacturers, **iwis is an expert partner on all aspects of chain lubrication**.

### SUMMARY

Adequate and effective lubrication of chain joints prolongs the service life of a chain many times over. Selection of the right lubricant and appropriate lubrication method guarantee reduced wear and additional corrosion protection.

Our technical **Service-Team** will be glad to advise you on chain maintenance and handling.  
Please get in touch!

Tel: +49 89 76909-1500 | Fax: -1198  
E-Mail: sales-muenchen@iwis.com



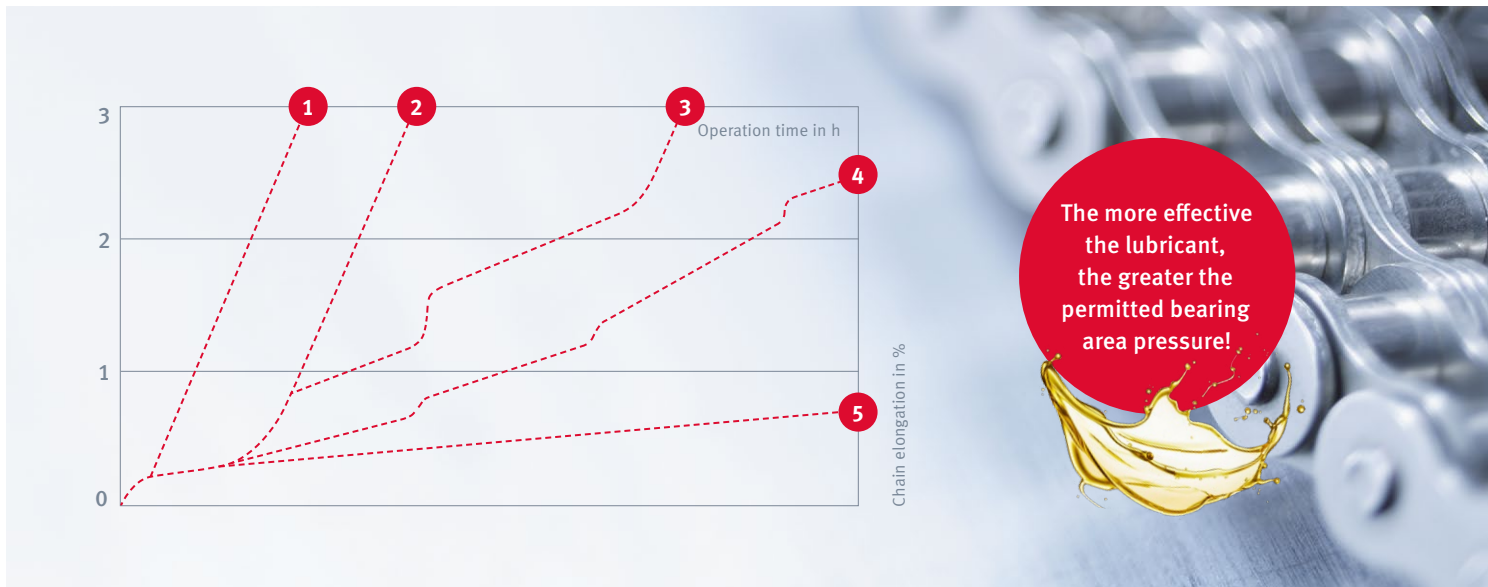

## About chain elongation, lubrication conditions and roller chains: The correlation between chain elongation and lubrication

### 1 Dry running

Heavy wear results in rapid destruction of the chain.

### 2 One-time initial lubrication

Wear is delayed until the lubricant has been used up.

### 3 Occasional dry running

when relubrication intervals are too long.

### 4 Partly inadequate lubrication

results in irregular wear – caused by poor-quality, contaminated, unsuitable or insufficiently applied lubricant.

### 5 All-round lubrication

Significant wear reduction resulting in chain reliability and long service life.

Our maintenance-free, self-lubricating MEGAlife chains can be fitted as an alternative.

## Longer chain service life with the right relubrication

If you find that your chain is insufficiently lubricated, we recommend the following action: clean the chain with a very low-viscosity oil or suitable wax product to loosen dirt particles and

remove old lubricant and other contaminants from the chain joints. After the chain has been cleaned, relubricate it – following our practical hints – using a suitable relubricant.

### PRACTICAL HINT

Continuous relubrication with a suitable quantity of lubricant is much more effective than long lubrication intervals with large quantities of lubricant. To determine the **optimum quantity of lubricant**, we recommend starting with 3 ml of lubricant per 1 m of chain (for 10B-1) and gradually increasing the dosage until you have found the correct quantity.

As a rule, the **lubrication status in the chain joint** can be checked by opening a connecting link. The surface of the pins must be covered by a clear, clean layer of lubricant.

### The following abnormalities could be signs of insufficient relubrication:

- Formation of metal dust/rust
- Unusual noise level, squeaking
- Unusually high chain elongation
- Twisted pins
- Heavy wear of sprockets
- Increased power consumption of drive motor
- Heat discoloration/tarnishing

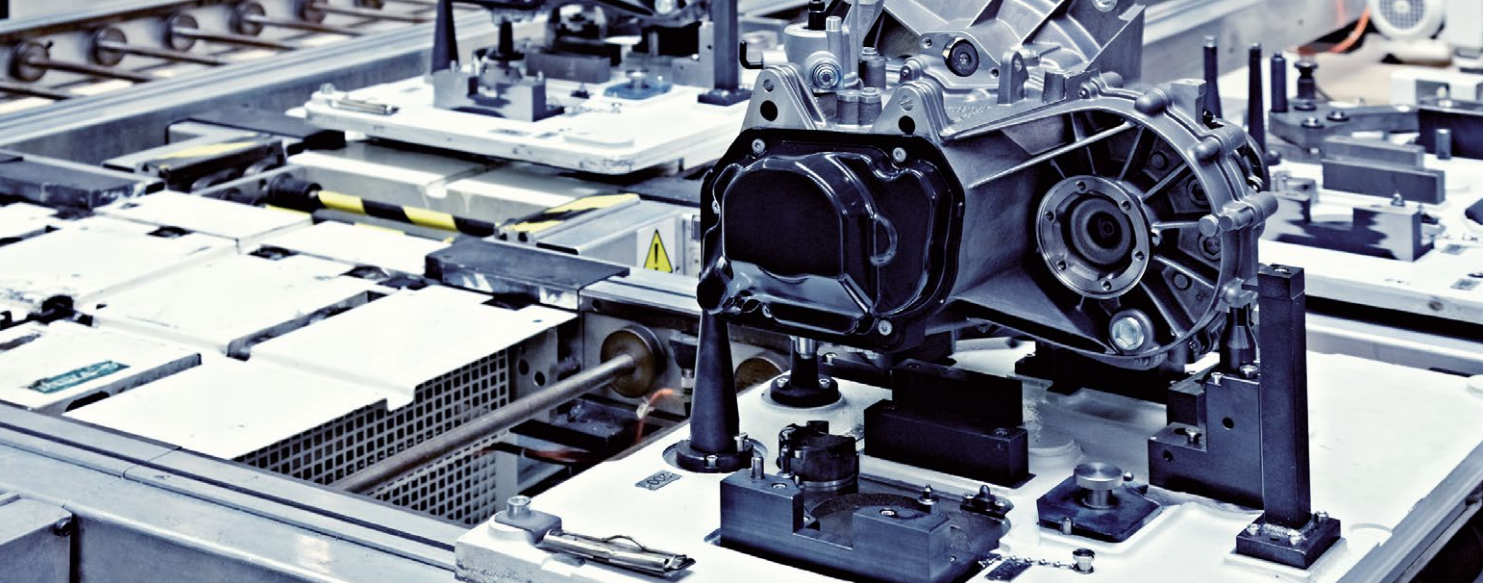

## Correct relubrication in practice



### 1. Preparation

Chain wear most frequently starts in the joint area, so it is essential to ensure that there is always sufficient lubricant around the pins and bushes. Ensure that the chain is thoroughly cleaned before relubrication to guarantee optimum penetration of the lubricant. The best cleaning technique is to use a brush and cleaning spray. In most cases, complete degreasing of the chain is very complex and time-consuming, so it is not recommended.

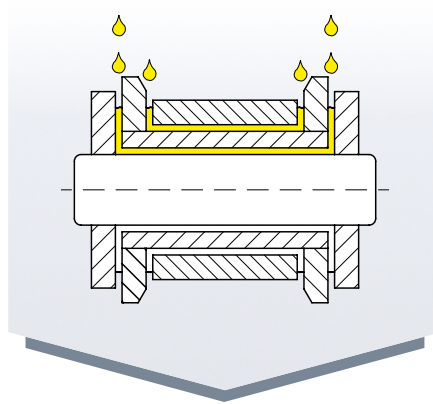

### 2. Lubricant application

Selecting the most suitable relubricant in combination with the right application technique is the best way to guarantee maximum chain service life.

Regardless of how the relubricant is applied, it must always penetrate the joint (the space between pin and bush). To ensure this, the lubricant is applied between the outer and inner plate. The viscosity of the lubricant also plays a major part. The iwis range of relubricant sprays has proved highly successful in day-to-day use.

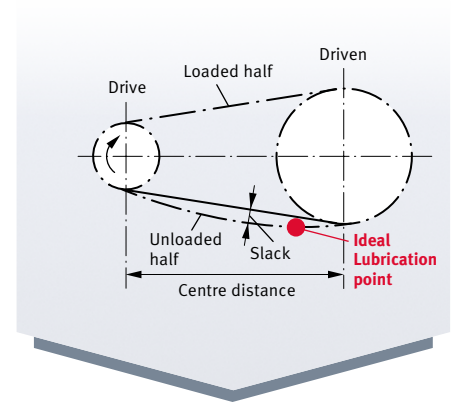

### 3. Lubrication point

To ensure that the lubricant penetrates the chain joint, it should be applied directly to the gap between inner and outer plate and between roller and bush. The ideal application point is positioned on the slack strand, because this gives the lubricant plenty of time to reach the areas of the chain where it is required to act.



## Recommended relubricants

Selecting an effective lubricant and the right relubrication technique are essential to ensure efficient relubrication. We offer the following range:



### VP6 SuperPlus Spray

VP6 Kombi SuperPlus Spray is a fully synthetic, high-adhesion, high-temperature chain oil. Suitable for all industrial chain applications.

#### Highlights:

- Temperature range from 0 °C to 250 °C
- Wide range of applications
- Easy to apply
- High-performance lubricant developed especially for chain applications
- Optimum penetration
- Silicone-free

**VP6 SuperPlus is suitable for use as a relubricant with the following iwis initial lubricants:<sup>1</sup>**

- JWIS : IP2, IP3, IPW, IP4, IP9, IP14
- ELITE : EL-1, EL-3, EL-4, EL-6, EL-8, EL-9



### **NEW** VP8 FoodPlus Spray

VP8 FoodPlus Spray is a relubricant for chains in food applications. Thanks to its outstanding wear protection properties, combined with a wide temperature range and corresponding food safety certificates, it can be used in a wide range of applications in the food industry.

#### Highlights:

- NSF H1 food-grade approval (No. 157999)
- MOSH/MOAH-free
- Precise, economic application possible
- Optimum penetration of chain joint
- Temperature range from -35 °C to +135 °C
- Free of animal products and ethanol
- Silicone-free

**VP8 FoodPlus is suitable for use as a relubricant with the following iwis initial lubricants:<sup>2</sup>**

- JWIS: IP16, also compatible with IPO
- ELITE: EL-2, iwiDUR

VP8 FoodPlus can also be used in applications with temperatures below 0 °C.

<sup>1</sup> Application-specific conditions such as ambient temperature must be taken into account.

<sup>2</sup> On request, compatibility of our relubricant sprays with other iwis lubricants not listed here can be considered, taking the respective application into account.



## The right initial lubricant

The iwis lubricant portfolio offers the right initial lubricant for a wide range of different applications. Choosing the right initial lubricant with care is vital, as it plays a crucial role in ensuring controlled running-in elongation and a long chain service life. Besides the lubricant itself, the right lubricant application technique is also decisive for subsequent chain performance in continuous operation.

The drip time can be adjusted according to customer requirements, guaranteeing that there will always be sufficient lubricant in the chain joint and the outside of the chain covered only with a thin film of lubricant. This will, for instance, reduce the risk of oil dripping or spinning off in sensitive environments.

### Various aspects are crucial when choosing an initial lubricant:

1

Temperatures in the application

2

Contamination (type and quantity)

3

Moisture

4

Substances that may come into contact with the chain

5

Frequency and method of cleaning

6

Compatibility with the relubricant

7

Drive chain speeds

**We will be glad to help you to choose suitable lubricants.**



## Our recommendation for the right initial lubricant, depending on application and chain type used

Application/environment	Requirement(s)	Chain type	JWIS lubricant	ELITE lubricant
Standard drives		Standard roller chain	IP2	EL4
	High loads	JWIS SL nickel-plated roller chain	IP2	EL4 eliDUR+
	High loads + no contamination by lubricant	JWIS MEGAlife	–	–
Damp/corrosive environment		JWIS CF ELITE CF	Dry, iwiDUR*	Dry, eliDUR+*, iwiDUR*
	Maintenance-free	JWIS b.dry	Dry, iwiDUR*	–
	Medium loads	JWIS CR	Dry, IP3*	–
	High loads	Nickel-plated roller chain	IP2, IP9	eliDUR+, EL3
Dusty environment		Standard roller chain	IPW	iwiDUR
	Maintenance-free	JWIS MEGAlife	IPW	–
Sensitive environment	No contamination by lubricant	JWIS MEGAlife	Dry, IPW*	–
	No contamination by lubricant + Drive chain speed > 3m/s	JWIS MEGAlife II	Dry, IPW*	–
High temperatures	< 70 °C	JWIS SL JWIS MEGAlife JWIS CR Nickel-plated roller chain	IP3/IP4	EL4, eliDUR+
	> 70 °C	JWIS SL JWIS CR Nickel-plated roller chain	IP3/IP4	EL1, EL4, EL5
High standards of hygiene		JWIS MEGAlife Nickel-plated roller chain	Dry, IPW*	Dry, iwiDUR*
	Corrosive environment	JWIS CR	Dry, IP3*	–
	Corrosive environment + maintenance-free	JWIS b.dry	Dry, iwiDUR*	–
Food processing			IP16	iwiDUR, EL2
	Corrosive environment	JWIS b.dry	Dry, iwiDUR*	–
	Corrosive environment + high loads	JWIS CR	Dry, IP3*	–

\* if possible



## Initial lubricants

Overview of temperature ranges

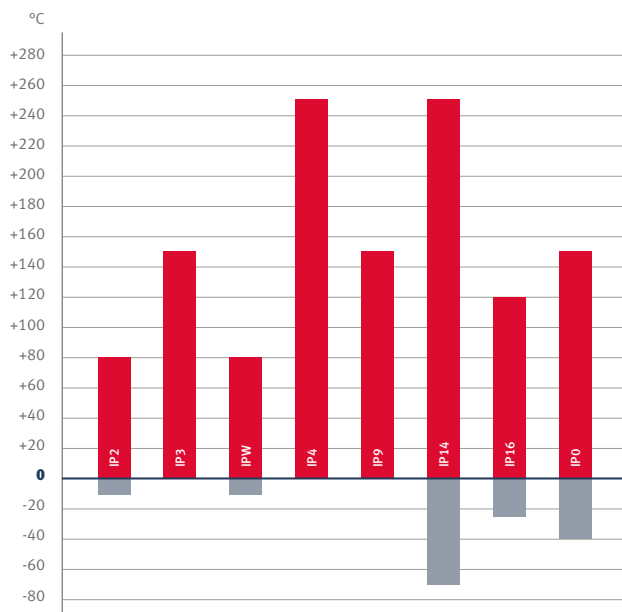

### IP2

Standard lubricant with good lubricating effect and outstanding corrosion protection for all applications.

### IP3

Long-term lubricant for high-speed drives, absolutely non-drip and non-splash.

### IPW

High-performance lubricating wax with good adhesion and outstanding wear protection, permitting significantly longer relubrication intervals. Can be used without problems in dusty or powdery environments.

### IP4

Thermally stable high-temperature lubricant that provides good protection against wear and corrosion.

### IP9

Corrosion protection for preservation with minimal lubricating effect.

### IP14

Dry lubricant for slow-running chain drives and low to medium loads.

### IP16

Food-grade lubricant with good wear and corrosion resistance. Meets the stringent requirements of USDA-H1 and LMBG (NSF No. 154891).

### IPO

Low-temperature lubricant with optimum lubricating effect. Free-flowing across entire temperature range.

### IMPORTANT

Choosing the right initial lubricant for the application in question plays a crucial role in ensuring controlled running-in elongation and a long chain service life. Besides the lubricant itself, the right lubricant application technique is also decisive for subsequent chain performance in operation.

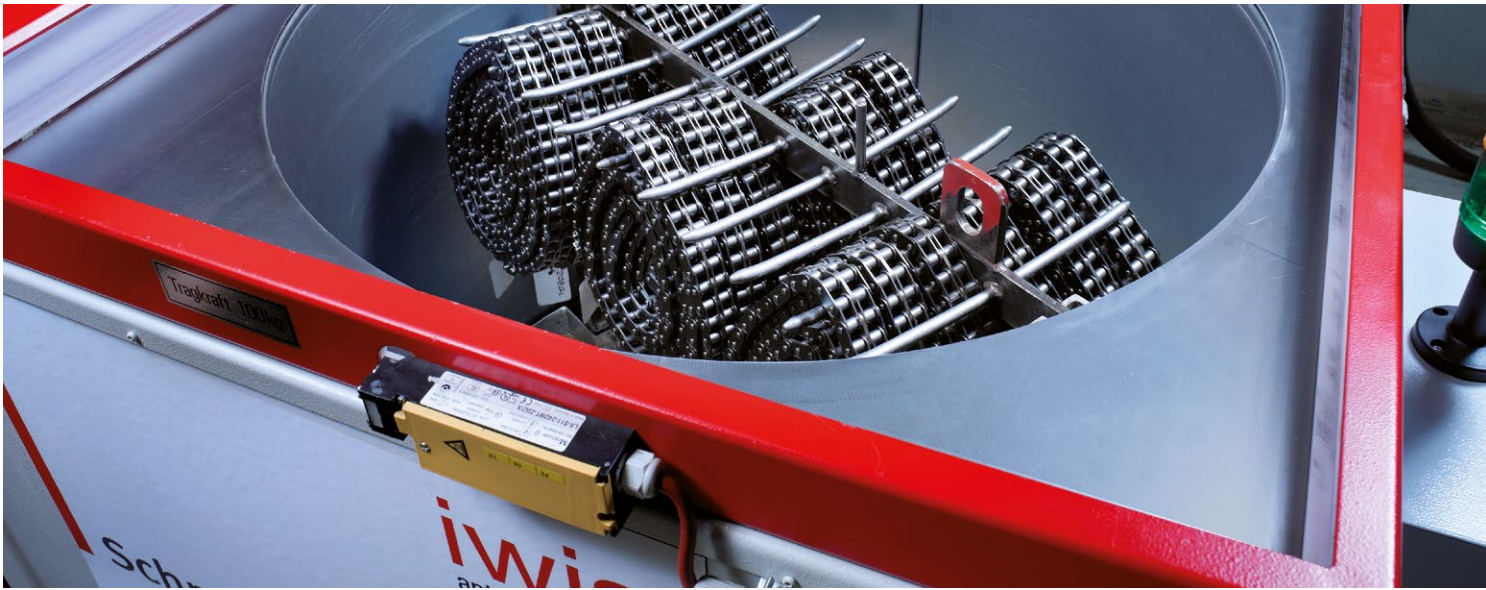

## Initial lubricants

Overview of temperature ranges

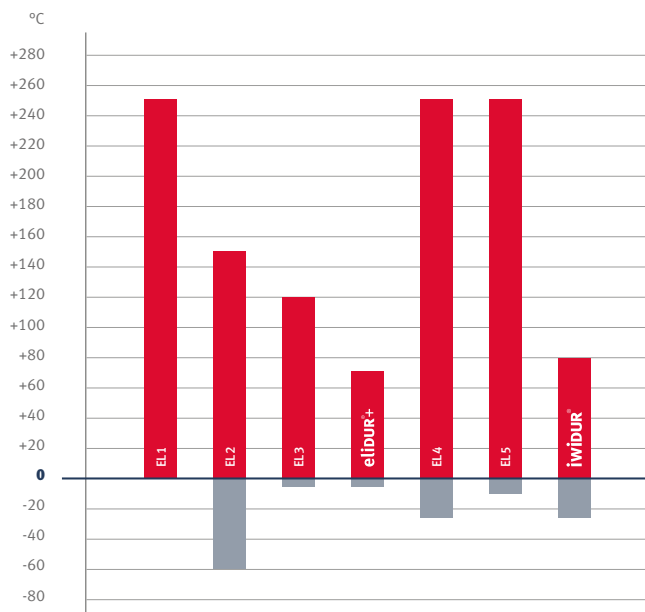

### EL1

High-performance lubricant for operating temperatures up to 250 °C.

### EL2

FDA H1-rated food-grade lubricant.

### EL3

Long-term, mineral oil-based lubricant with special additives to improve adhesion and corrosion protection.

### eliDUR+

Lubrication and corrosion protection, specially designed for use on roller chains.

### EL4

Synthetic high-temperature lubricant with maximised operating temperature range.

### EL5

Synthetic Teflon long-term lubricant for high-temperature applications.

### iwIDUR

New generation of food-grade wax lubricant with FDA-H1 classification (NSF No. 154890).

### Highlights eliDUR+

**eliDUR+** is an outstanding lubricant and anti-corrosive agent that was specially developed for roller chains. It contains additives that provide protection against extreme pressure, wear and corrosion. It has **excellent wear values** and **improves the performance** of ELITE roller chains on wear test benches by **up to 300 %**.



## Maintenance-free roller chains: When relubrication is not possible

The purpose of correct (re-)lubrication is to minimise friction in the chain joint i.e. between pin and bush. The more friction occurs, the greater the incidence of wear.

However, some applications do not permit the use of “liquid” oil as an initial lubricant or relubricant. In order to achieve the longest possible chain service life in such cases, a chain can be treated with grease or wax as an initial lubricant. This can complicate relubrication at a later date, however.

There are other ways of protecting the chain joint against wear by treating the surfaces of pins and bushes, the “partner components” subject to the most friction. What are known as “**maintenance-free**” versions have also proved to be a practical solution. These include chains with bushes made from sintered material which permit the long-term “storage” of lubricant in the chain joint, so that the outside of the chain stays dry but the joint area is well lubricated. This iwis range of maintenance-free chains is marketed under the **JWIS-MEGAlife** brand.

Another way of reducing friction is to use bushes made from special high-performance plastic, which takes over the friction reduction task normally performed by lubricant and allows the chain to run completely without lubrication. The leading products in this field are **JWIS-b.dry** chains made from CF stainless steel – ideal for use in sensitive environments!

The same rule applies to maintenance-free chains as to other versions: relubrication is recommended as soon as it possible/permissible, as this can significantly prolong the service life of the chain.

Please feel free to contact us if you need help or advice in relation to concrete application cases.



## Maintenance-free iwis chains for added value



### MEGAlife

MEGAlife maintenance-free roller chains feature chemically nickel-plated individual components for corrosion protection, and can be used in a temperature range from -40 ° to +150 °C.

Special oil-impregnated sintered bushes are a **highlight in terms of wear resistance and prolonged service life**, as they provide long-term self-lubrication of the chain bearing – no additional lubricants are required.

#### Highlights

- **Seamless sintered bush ①** made of a material developed specifically for this application, hardened and treated to optimize its tribological properties
- Pin ② with **wear-resistant, friction-optimized coating**
- Seamless roller ③ with **corrosion-resistant coating** and optimized geometry for the sintered bush

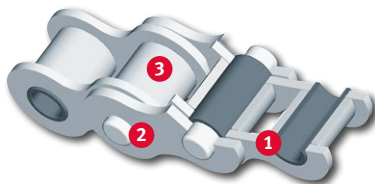

### b.dry

b.dry roller chains are made from rust- and maintenance-free CF stainless steel, and their optimized link design is a **high-precision highlight**. The secret of the b.dry range: “steel-on-steel” is a thing of the past!

Our b.dry bushes are made from a special high-performance polymer and are completely lubricant-free. To date, the properties of this material are unrivalled and unique.

#### Highlights

- **High-performance polymer bush ①** made from FDA-compliant material
- Thin-walled seamless **stainless steel bush ②**, ball-drifted
- Base chain: **Jwis CF stainless steel chain ③**



#### Benefits of our maintenance-free roller chains:

Optimized wear properties, very high fatigue strength and breaking strength, high-quality long-lasting corrosion protection, reduced downtime and maintenance costs for machines and plant, reduced risk of product or production facility contamination.

For more information, see our product flyer or online at [www.iwis.com/megalife](http://www.iwis.com/megalife)



For more information, see our product flyer or online at [www.iwis.com/bdry](http://www.iwis.com/bdry)



# Our subsidiaries

## Germany

iwis antriebssysteme GmbH & Co. KG  
Albert-Roßhaupter-Straße 53  
81369 München  
Tel. +49 89 76909-1500  
Fax +49 89 76909-1198  
sales-muenchen@iwis.com

## Germany

iwis antriebssysteme GmbH  
Essener Straße 23  
57234 Wilnsdorf  
Tel. +49 2739 86-0  
Fax +49 2739 86-22  
sales-wilnsdorf@iwis.com

## Germany

iwis agrisystems  
Schützenweg 5  
36205 Sontra  
Tel. +49 5653 9778-0  
Fax +49 5653 9778-26  
agrisystems@iwis.com

## Brazil

iwis Sistemas de Transmissão  
de Energia Mecânica Ltda.  
Rua Bento Rosa, nº 1816  
Bairro Hidráulica  
95.900-000 Lajeado, RS  
Tel. +55 51 3748-7402  
salesbrazil@iwis.com

## China

iwis drive systems (Suzhou) Co., Ltd.  
No. 266 LvliangShan Road  
215153 Suzhou SND  
Tel. +86 512 8566-3010  
Fax +86 512 8566-3009  
salescn@iwis.com

## France

iwis systèmes de transmission  
10, rue du Luxembourg  
69330 Meyzieu  
Tel. +33 4374515-70  
Fax +33 4374515-71  
salesfr@iwis.com

## Great Britain

iwis drive systems Ltd.  
Unit 8c Bloomfield Park  
Bloomfield Road, Tipton  
West Midlands, DY4 9AP  
Tel. +44 12 15213600  
Fax +44 12 15200822  
salesuk@iwis.com

## India

iwis engine systems India Pvt. Ltd.  
Teerth Technospace  
Unit No. C 409, Survey No. 103  
Adjoining Mercedes Benz showroom  
Baner Pune 411045 India  
Tel. +91 7030922297  
salesin@iwis.com

## Italy

iwis drive systems Srl  
Via Carlo Rota, 10  
20090 Monza (MB)  
Tel. +39 340 9296142  
Fax +49 89 7690949-1726  
salesit@iwis.com

## Canada

iwis drive systems, Inc.  
101-19097, 26th Avenue,  
Surrey BC V3Z 3V7  
Tel. +1 604 560-6395  
Fax +1 604 560-6397  
salesca@iwisusa.com

## South Korea

iwis engine systems Korea Co., Ltd.  
Office No. 403-2, 322 Yanghyeon-ro  
(Yatap-dong, Korea Design Center)  
Bundang-Gu, Seongnam Si,  
Gyeonggi-Do, Korea (ZIP) 13496  
Tel. +82 31 788-7545  
saleskor@iwis.com

## Switzerland

iwis AG Kettentechnik  
Bahnweg 4 (Postfach)  
5504 Othmarsingen  
Tel. +41 62 8898999  
Fax +41 62 8898990  
info@iwis-ketten.ch

## South Africa

iwis drive systems, (Pty) Ltd.  
Unit 3, 127 Koornhof Road  
Meadowdale, 1613  
Tel. +27 11 392-2306  
Fax +27 11 392-3295  
salessa@iwis.com

## Czechia

iwis antriebssysteme spol. s r.o.  
Přísecká 893  
38601 Strakonice  
Tel. +420 383 411811  
Fax +420 383 321695  
salescz@iwis.com

## Turkey

iwis tahrik sistemleri ltd. şti.  
Kağıthane Ofis Park 4C-Blok  
Bağlar Cad. No: 14  
34406 Kağıthane-Istanbul  
Tel. +90 212 939-3843  
Fax +90 212 939-3701  
salestr@iwis.com

## USA

iwis drive systems, LLC  
Building 100, 8266 Zionsville Road  
Indianapolis, IN 46268  
Tel. +1 317 821-3539  
Fax +1 317 821-3569  
sales-us@iwis.com

[www.iwis.com](http://www.iwis.com)

Your sales representative

**iwis**  
antriebssysteme  
wir bewegen die welt