



# WORKSHOP EQUIPMENT RSC55



To answer the requirements of a market where the emphasis is increasingly on quality, design and customization, Beta Utensili has developed "Racing System C55", modular garage furniture shaped on your needs, while allowing you to create a modern work environment.



## QUALITY

Beta's best Italian-made quality to furnish your garage



## ORGANIZATION

A sensibly organized workstation, synonymous with optimized work



## DESIGN

Refined, captivating finishes for a tidy, attractive workstation



## MODULARITY

Modular garage fitting your spaces and requirements





# WORKSHOP EQUIPMENT RSC55



**MADE IN ITALY**



Configure your workshop online  
Go to **www.rsc55.com**

## YOUR COLOURS FOR YOUR WORKSHOP!

RSC55 allows you to order the benches and tool wall system with shutter in a neutral (grey) version and customize the vertical coloured inserts by choosing from 7 different adhesive tapes.

**Order the vertical insert  
in a neutral colour**

**Order the vertical insert**

Choose the colour to your taste or according  
to your company's colours



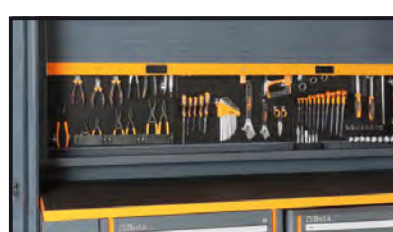

Comprehensive combination comprising:

- Single-door tool cabinet (C55A1)
- Two-door tool cabinet (C55A2)
- Workbench (C55BO/2)
- Workbench with sockets (C55PRO BO/2)
- Mobile roller cab with 7 drawers (C55C7)
- Fixed module with 2 storage drawers (C55M2)
- Fixed module with 7 drawers (C55M7)
- Fixed service module (C55MS)
- Tool panel with suspended cabinets (C55/2PM)
- Tool panel with shutter (C55PS-O)

## C55AB

workshop equipment combination

Combination comprising:

- Two-door tool cabinet (C55A2)
- Workbench (C55BO/2)
- Fixed module with 7 drawers (C55M7)
- Fixed service module (C55MS)
- Tool panel with suspended cabinets (C55/2PM)

407 kg



C55AB

1 055000020



## C55PB/3

workshop equipment combination

Combination comprising:

- Workbench (C55BO/2)
- Roller cab module with 8 drawers (C55C8)
- Fixed module with 2 storage drawers (C55M2)
- Wall tool system with shutter (C55PS-O)

334 kg



C55PB/3

1 055000035



## C55PB-PRO/7

workstation for workshop equipment combination RSC55

Composed of:

### C55B

Workbench with worktop (2050x700 mm) covered with a shockproof, nonscratch ABS coat resistant to oils and hydrocarbons.

Fitted with:

- Holes for a vice (1599F/150 - 1599GI/150, to be ordered separately)
- Vertically adjustable feet

### C55M7

Fixed module with seven drawers (588x367 mm) with ball bearing slides

- Aluminium opening system throughout length of drawer
- Drawer bases protected by foamed rubber mats
- Front centralized lock
- Can be fitted with thermoformed trays

### C55MS

Fixed service module

- Built-in waste bin
- Paper roll compartment
- Storage drawer, 305x270 mm

### C55/2PM + C55/PF

Tool wall system with 2 suspended cabinets

- 2 suspended cabinets, 1024x400x300 mm, with gas springs
- 2 under-cabinet panels, 1024x620x25 mm
- 2 under-cabinet perforated tool panels, 1024x620x25 mm

350 kg

C55PB-PRO/7

1 055000065



## C55PB-PRO/8

workstation for workshop equipment combination RSC55

Composed of:

### C55B

Workbench with worktop (2050x700 mm) covered with a shockproof, nonscratch ABS coat resistant to oils and hydrocarbons.

Fitted with:

- Holes for a vice (1599F/150 - 1599GI/150, to be ordered separately)
- Vertically adjustable feet

### C55C7

Mobile roller cab with seven drawers (588x367 mm) with ball bearing slides

- 4 castors Ø 100 mm, 2 fixed and 2 steering (one with brake)
- Aluminium opening system throughout length of drawer
- Drawer bases protected by foamed rubber mats
- Front centralized lock
- Can be fitted with thermoformed trays

### C55MA

Fixed two-door module

- Push-pull opening system
- With lock
- Interior shelf, vertically adjustable

### C55PS

Tool wall system with shutter and framework

- Aluminium shutter, vertically adjustable, with lock
- Removable perforated tool panel

347 kg

C55PB-PRO/8

1 055000066



## C55B/2

2-m-long workbench, for workshop equipment combination

With worktop (2050x700 mm) covered with a shockproof, non-scratch PVC coat, resistant to hydrocarbons

- Holes for a vice (1599F/150 - 1599GI/150, to be ordered separately)
- Vertically adjustable feet

105 kg

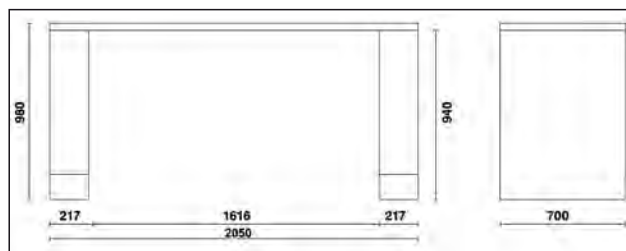
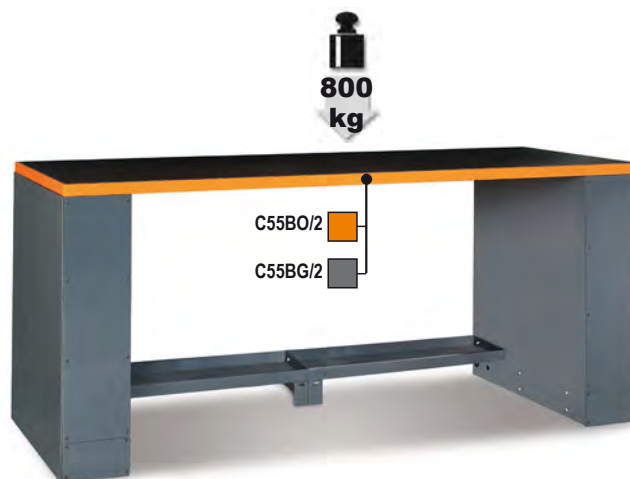

C55BO/2	1	055000101
C55BG/2	1	055000111

## C55PRO B/2

2-m-long workbench, for workshop equipment combination

With worktop (2050x700 mm) covered with a shockproof, non-scratch PVC coat, resistant to hydrocarbons

Built-in sockets and hose reel:

- Schuko socket +16+10A
- EU Plug 10A
- Compressed air outlet with hose reel, Ø 8 mm, hose length: 10 m.
- Holes for a vice (1599F/150 - 1599GI/150, to be ordered separately)
- Vertically adjustable feet

110 kg

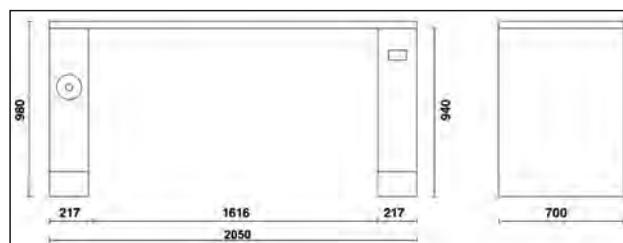
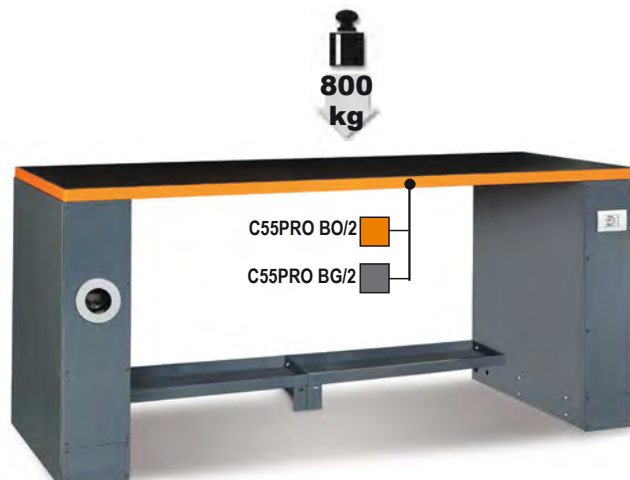

C55PRO BO/2	1	055000151
C55PRO BG/2	1	055000171

## C55B/2,8

2.8-m-long workbench, for workshop equipment combination

Worktop (2850x700 mm) covered with a shockproof, non-scratch PVC coat, resistant to hydrocarbons

- Holes for a vice (1599F/150 - 1599GI/150, to be ordered separately)
- Vertically adjustable feet

131 kg

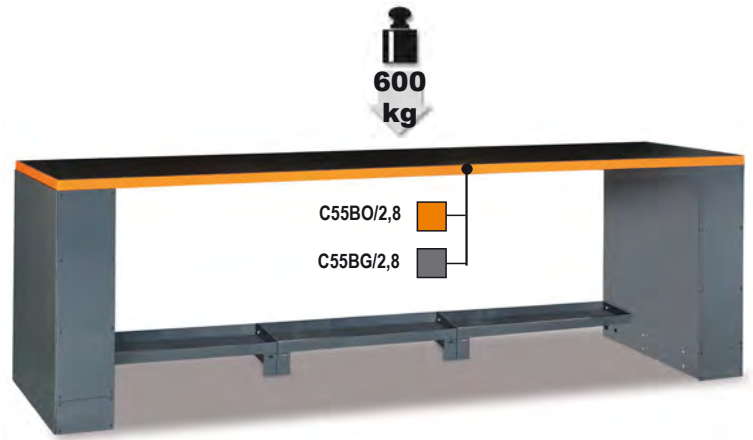

C55BO/2,8

C55BG/2,8

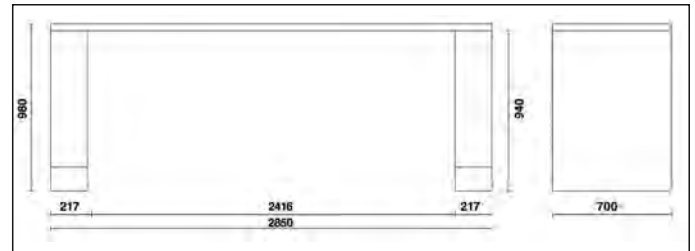

C55BO/2,8	1	055000261
C55BG/2,8	1	055000281

## C55PRO B/2,8

2.8-m-long workbench, for workshop equipment combination

With worktop (2850x700 mm) covered with a shockproof, non-scratch PVC coat, resistant to hydrocarbons

Built-in sockets and hose reel:

- Schuko socket +16+10A
- EU Plug 10A
- Compressed air outlet with hose reel, Ø 8 mm, hose length: 10 m.
- Holes for a vice (1599F/150 - 1599GI/150, to be ordered separately)
- Vertically adjustable feet

134 kg

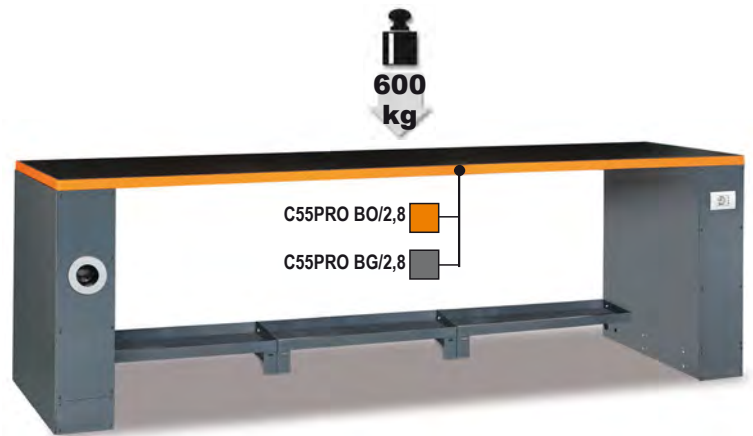

C55PRO BO/2,8

C55PRO BG/2,8

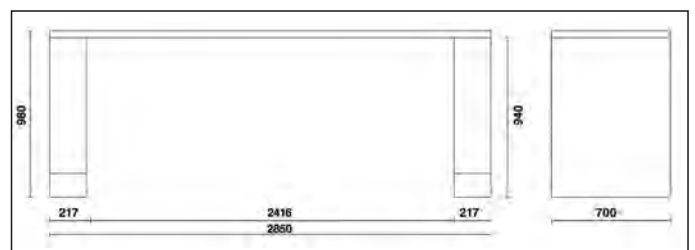

C55PRO BO/2,8	1	055000271
C55PRO BG/2,8	1	055000283

## C55B-D4

double 4-m-long workbench with central leg

Worktop (4100x700 mm) covered with a shockproof, non-scratch PVC coat, resistant to hydrocarbons

- Holes for a vice 1599F/150 - 1599GI/150 (to be ordered separately)
- Vertically adjustable feet
- Double central leg with compartment and slide-away door, 350x750 mm

185 kg

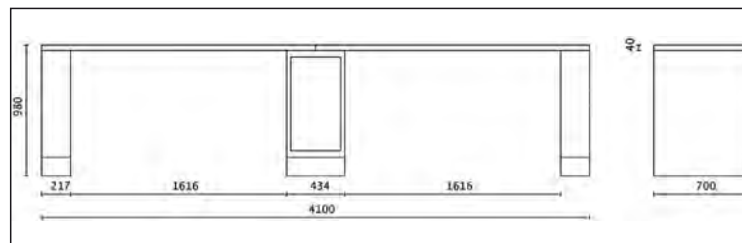
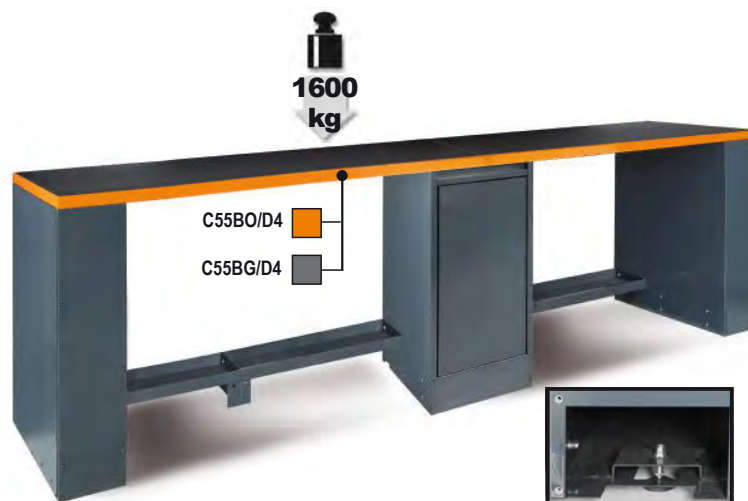

C55BO/D4	1	055000109
C55BG/D4	1	055000119

## C55PRO B-D4

double 4-m long workbench with central leg

With worktop (4100x700 mm) covered with a shockproof, non-scratch PVC coat, resistant to hydrocarbons

Built-in sockets and cable reel:

- Schuko socket +16+10A
- EU Plug 10A
- Compressed air outlet with hose reel, Ø 8 mm, cable length: 10 m.
- Holes for a vice (1599F/150 - 1599GI/150, to be ordered separately)
- Vertically adjustable feet
- Double central leg with tool compartment and door, 365x750 mm

190 kg

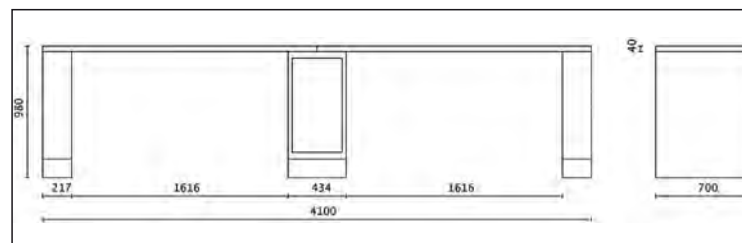
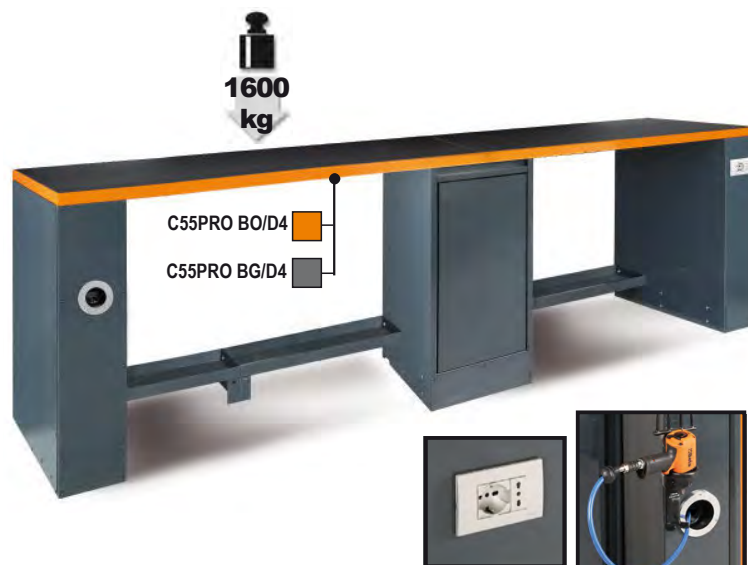

C55PRO-BO/D4	1	055000159
C55PRO-BG/D4	1	055000179

 **Beta**

## C55B/G

universal leg for workshop equipment workbench

- With vertically adjustable feet

32 kg

C55B/G

1 055000096

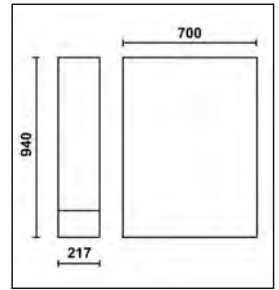

## C55B/GAA

universal leg for workbench with built-in hose reel

- Built-in automatic hose reel for compressed air or cold water, Ø 8 mm
- Hose length: 10 m 1900S 8x10
- With vertically adjustable feet
- Front and side access

36,4 kg

C55B/GAA

1 055000099

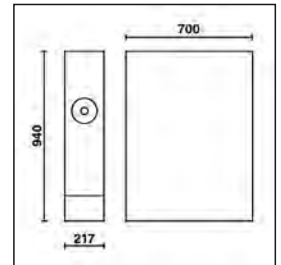

## C55B/GDP

double leg for adjoining workshop equipment workbenches

- Paper roll holder compartment
- Compartment with door
- With vertically adjustable feet

45 kg

C55B/GDP

1 055000292

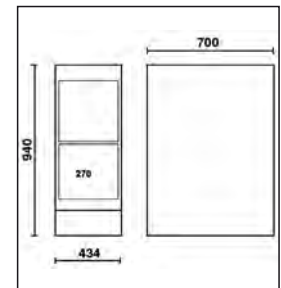

## C55B/GDS

double leg for adjoining workshop equipment workbenches

- Compartment with slide-away door, 365x750 mm
- With vertically adjustable feet

45 kg

C55B/GDS

1 055000291

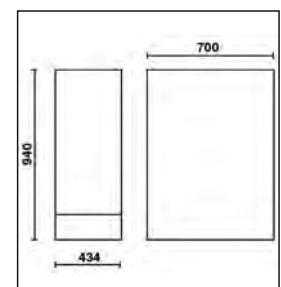

## C55B/GE

universal leg with power sockets for workshop equipment workbench

- Schuko socket+16+10A
- EU Plug +10A
- With vertically adjustable feet

30,4 kg

C55B/GE

1 055000097

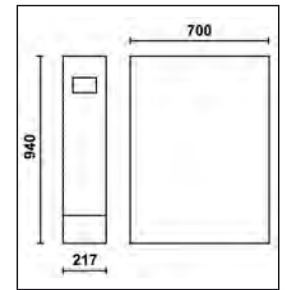

## C55B/GAE

universal leg with built-in electrical cable reel for workbench, for workshop equipment combination

- Built-in automatic cable reel with Schuko type socket 1844 15H05SCK
- Cable length: 15 m
- With thermal protection switch
- With vertically adjustable feet
- Front and side access

37,5 kg

C55B/GAE

1 055000094

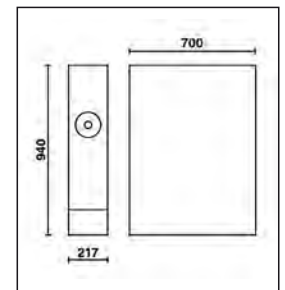
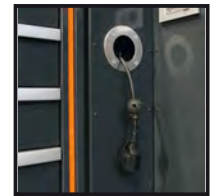

# Beta

## C55/PL-1,024

1-m-long worktop for workbench extension

Painted sheet metal worktop (1024x700 mm) covered with a shockproof, non-scratch PVC coat, resistant to hydrocarbons

21 kg

C55/PLO-1,024	1	055000130
C55/PLG-1,024	1	055000131



## C55B PT/2

2-m-long worktop for workbench, for workshop equipment combination

Painted sheet metal worktop (2050x700 mm) covered with a shockproof, non-scratch PVC coat, resistant to hydrocarbons  
Holes for a vice (1599P/150 - 1599GI/150, to be ordered separately)

43 kg

C55BO PT/2	1	055000106
C55BG PT/2	1	055000116



## C55B PT/2,8

2.8-m-long worktop for workbench, for workshop equipment combination

Painted sheet metal worktop (2850x700 mm) covered with a shockproof, non-scratch PVC coat, resistant to hydrocarbons  
Holes for a vice (1599P/150 - 1599GI/150, to be ordered separately)

67 kg

C55BO PT/2,8	1	055000266
C55BG PT/2,8	1	055000286



## C55RB

shockproof, non-scratch PVC coat, resistant to hydrocarbons

For protecting worktop.

C55RB/2: for 2-m-long worktop

C55RB/2.8: for 2.8-m-long worktop

C55RB/0.7: for 700x700mm worktop

C55RB/1: for 1-m-long worktop



C55RB/2	1	055000195
C55RB/2,8	1	055000196
C55RB/0,7	1	055000199
C55RB/1	1	055000198

## C55B/VS

lower workbench bracket, 0.8 m long

Dimensions: 800x230x60 mm

4,2 kg

C55B/VS	1	055000095
---------	---	-----------

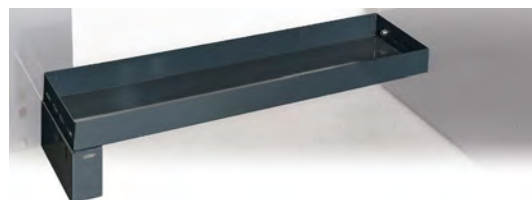

## C55C7

mobile roller cab with seven drawers, for workshop equipment combination

- 7 drawers (588x367 mm), with ball bearing slides
- 4 castors Ø 100 mm, 2 fixed (one with brake) and 2 steering
- Aluminium opening system throughout length of drawer
- Drawer bases protected by foamed rubber mats
- Front centralized lock
- Can be fitted with foam trays

79 kg

1000 kg



h	max
70 mm	30 kg
245 mm	40 kg

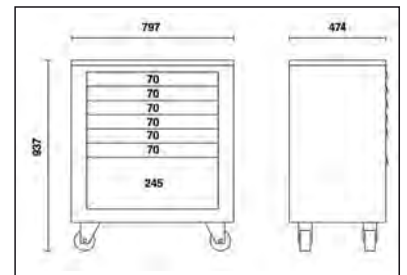
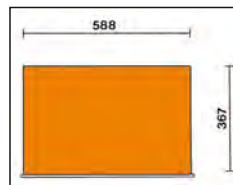

C55C7

1 055000201

# Beta



## C55C8

roller cab module with eight drawers, for workshop equipment combination

- 8 drawers(588x367 mm) with ball bearing slides
- 4 castors Ø 100 mm, 2 fixed (one with brake) and 2 steering
- Aluminium opening system throughout length of drawer
- Drawer bases protected by foamed rubber mats
- Front centralized lock
- Can be fitted with foam trays

80,8 kg



h	max
70 mm	30 kg
175 mm	40 kg

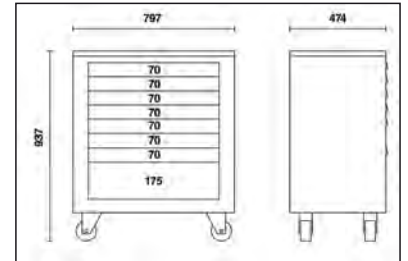
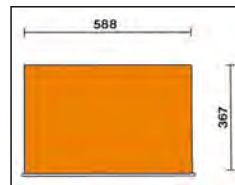

C55C8

1 055000206

## C55M2

fixed module with 2 drawers, for workshop equipment combination

- 2 drawers (588x367mm) with ball bearing slides
- Aluminium opening system throughout length of drawer
- Drawer bases protected by foamed rubber mats
- Front centralized lock

66 kg



h	max
280 mm	40 kg
385 mm	40 kg

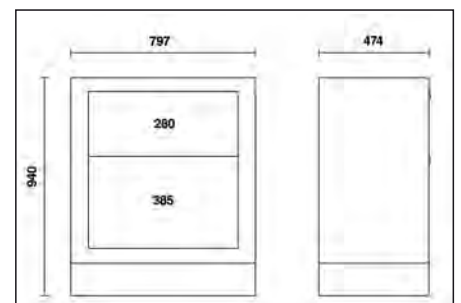
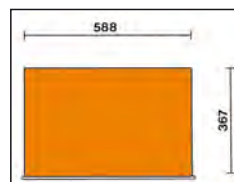

C55M2

1 055000202

## C55M4

fixed module with 4 drawers, for workshop equipment combination

4 drawers (588x367 mm) with ball bearing slides

- Aluminium opening system throughout length of drawer
- Drawer bases protected by foamed rubber mats
- Front centralized lock

75 kg

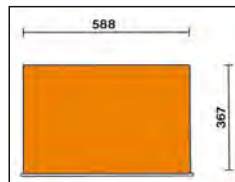

h	max
140 mm	30 kg
245 mm	40 kg

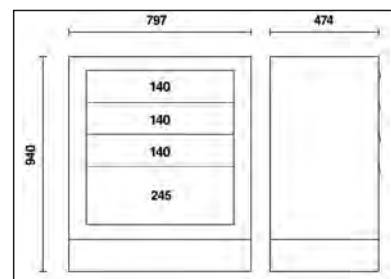

C55M4

1 055000212

## C55M7

fixed module with seven drawers, for workshop equipment combination

7 drawers (588x367 mm) with ball bearing slides

- Aluminium opening system throughout length of drawer
- Drawer bases protected by foamed rubber mats
- Front centralized lock
- Can be fitted with foam trays

78 kg

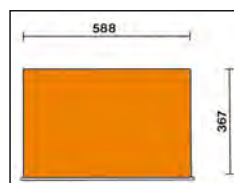

h	max
70 mm	30 kg
245 mm	40 kg

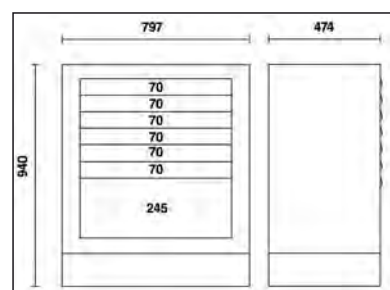

C55M7

1 055000203

## C55M8

fixed module with 8 drawers for workshop equipment combination

8 drawers (588x367 mm) with ball bearing slides

- Aluminium opening system throughout length of drawer
- Drawer bases protected by foamed rubber mats
- Front centralized lock
- Can be fitted with foam trays

📦 78,9 kg



h	max
70 mm	30 kg
175 mm	40 kg

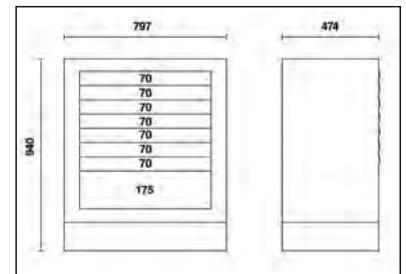
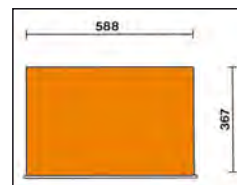

C55M8

1 055000207

## C55CS

fixed sorted waste collection module for workshop equipment combination

- Pull-out waste compartment (588x465) with ball bearing slides
- 2 capacious pull-out interior containers for sorting waste

📦 61,4 kg

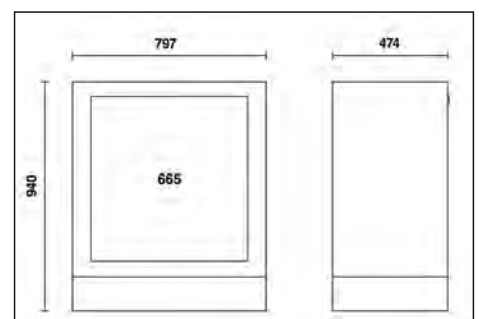

C55 CS

1 055000208

## C55MA

fixed two-door module, for workshop equipment combination

- Push Pull opening
- With lock • Interior shelf, vertically adjustable

📦 75 kg

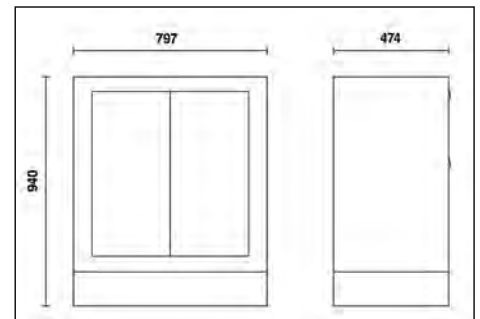

C55MA

1 055000205

## C55MDO

fixed oil distribution module  
for workshop equipment combination

- 2 reels with 7m - 1/2" hose included
- Complete with 2 guns with digital litre counter and automatic drip catcher.
- max. flow rate: 30 l/min
- viscosity: 8÷2000 mPas

📦 93,4 kg

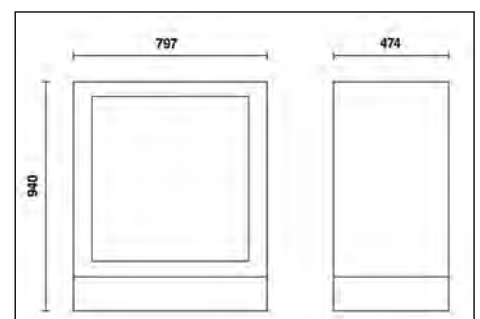

C55MDO

1 055000210

## C55MS

fixed service module, for workshop equipment combination

- Built-in waste bin
- Perforated paper roll compartment
- Storage drawer, 305x270 mm

75 kg

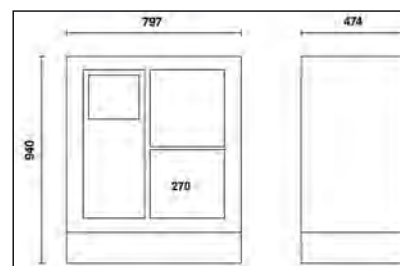

C55MS

1 055000204

## C55T3

trolley

- 3 tops covered in antislip ribbed rubber
- Ergonomic handle
- Two fixing options for central worktop
- Four castors Ø 100 mm (two with brakes)
- Static load capacity: 200 kg (distributed between 3 shelves)

22,8 kg

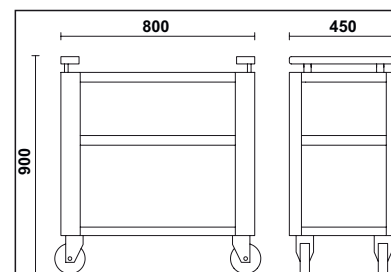

C55T3

1 055000219

## C55P/MCD

double central intermediate uprights

10 kg

C55P/MCD

1 055000257



## C55P/2MDX-SX

right/left wall uprights, pair

10 kg

C55P/2MDX-SX

1 055000253



## C55PM

suspended cabinet for workshop equipment combination, 1 m long

• Dimensions: 1024x400x300 mm; fitted with gas springs, making it easier to open and close door

23,4 kg

C55PM

1 055000302

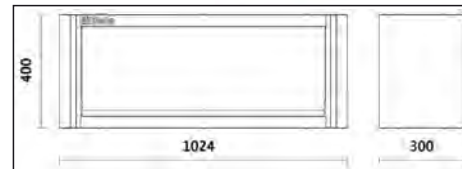

## C55PFA-1,0

self-supporting perforated panel, 1 m long, for workshop equipment combination

Perforated steel tool panel (1024x1020x25 mm)

11 kg

C55PFA-1,0

1 055000316

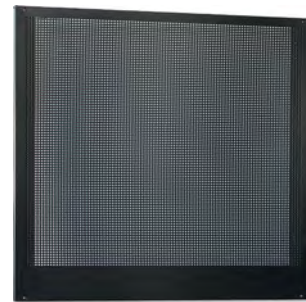

## C55/PF

perforated under-cabinet panel for workshop equipment combination, 1 m long

• Perforated tool panel (1024x600 mm)

6 kg

C55/PF

1 055000307

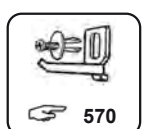

## C55PT1,0X0,6

under-cabinet panel, 1 m long

Dimensions: 1024x620x25 mm

8 kg

C55PT1,0X0,6

1 055000314



## C55PTE-1,0

under-cabinet panel, 1 m long

Dimensions: 1024x620x25 mm

Accommodates 2 power sockets (not included)

8 kg

C55PTE-1,0

1 055000319



## C55/2PM

tool wall system with 2 suspended cabinets, for workshop equipment combination

- 2 suspended cabinets, 1024x400x300 mm, fitted with gas springs, making it easier to open and close doors.
- Wall panel, 2050x620 mm; can accommodate perforated tool panels C55/PF (to be ordered separately)
- Supplied with framework
- Matches 2-m-long workbench

82,7 kg

C55/2PM

1 055000301

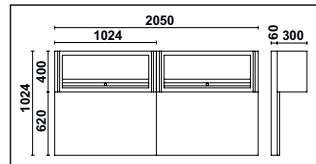
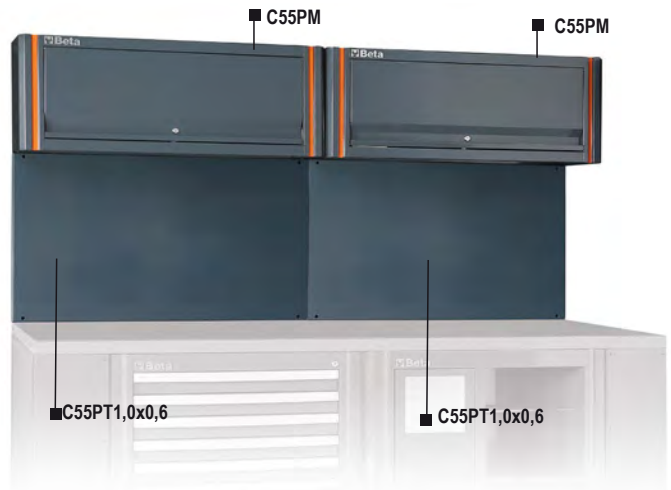

## C55PFA-0,8

self-supporting perforated panel, 0.8 m long, for workshop equipment combination

Perforated steel tool panel (800x1020x25 mm)

10 kg

C55PFA-0,8

1 055000315

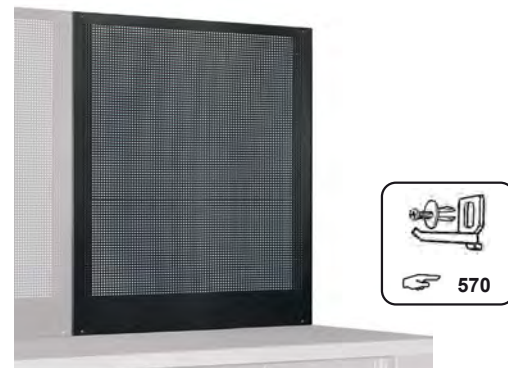

## C55PM/M0,8

suspended cupboard, 0.8 m long, for workshop equipment combination

Dimensions: 800x400x300 mm; fitted with gas springs making it easier to open and close door

19 kg

C55PM/M0,8

1 055000312



## C55PTE-0,8

under-cabinet panel, 0.8 m long

Dimensions: 800x620x25 mm

Accommodates 1 power socket (not included)

6 kg

C55PTE-0,8

1 055000318



## C55PT0,8X0,6

under-cabinet panel, 0.8 m long

Dimensions: 800x620x25 mm

7,8 kg

C55PT0,8X0,6

1 055000313



## C55/1PF

perforated tool panel, for workshop equipment combination

• Perforated tool panel (800x600 mm)

4,6 kg

C55/1PF

1 055000309

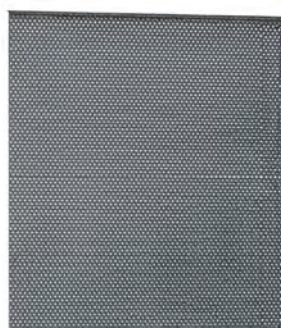

## C55PS

tool wall system with shutter, for workshop equipment combination

- Aluminium shutter, vertically adjustable, with lock
- Removable perforated tool panel
- Supplied with framework
- 50-hook GPS kit included
- Matches 2-m-long workbench

85,7 kg

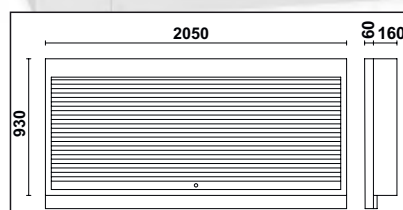

C55PS-O	1	055000250
C55PS-G	1	055000255

## C55PSE

tool wall system with shutter  
accommodating 2 power sockets

- Aluminium shutter, vertically adjustable, with lock
- Removable perforated tool panel
- Supplied with framework
- 50-hook GPS kit included
- Accommodates power sockets
- Matches 2-m-long workbench

85,7 kg

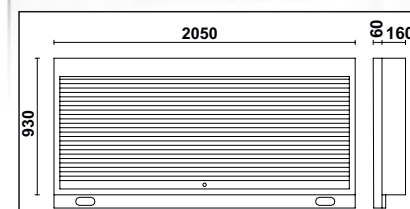
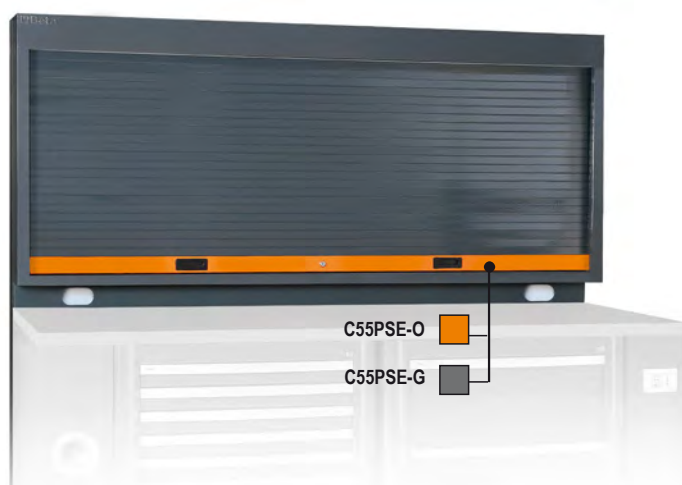

C55PSE-O	1	055000258
C55PSE-G	1	055000260

## C55AE

profile, 2 m long, accommodating power sockets

Dimensions: 2050x25x90mm  
Accommodates 2 power sockets

3 kg



C55AE	1	055000325
-------	---	-----------

## C55AC

self-supporting complete corner

Worktop (700x700 mm) with legs  
2 upper tool wall systems complete with 2 fixing shelves (665x150 mm)

63 kg

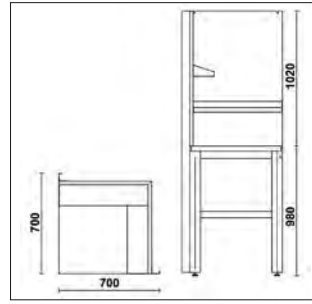

C55AC-O	1	055000360
C55AC-G	1	055000380

## C55KAI

corner worktop for workshop equipment combination

• Painted sheet metal worktop (700x700 mm) covered with a shockproof, non-scratch PVC coat, resistant to hydrocarbons

33 kg



C55KAI-O	1	055000365
C55KAI-G	1	055000385

## C55MP

steel corner wall shelves

Dimensions: 700x160x80 mm

3 kg



C55MP	1	055000374
-------	---	-----------

# Beta

## C55A1

sheet metal single-door tool cabinet, for workshop equipment combination

- 3 removable, vertically adjustable shelves
- convenient folding clothes rail under first shelf
- with lock
- usable interior dimensions: 1770x420x420 mm

47,3 kg

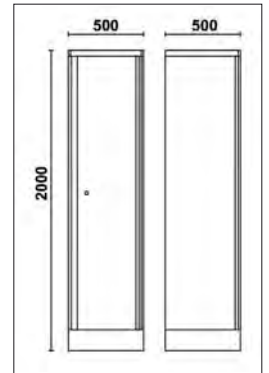
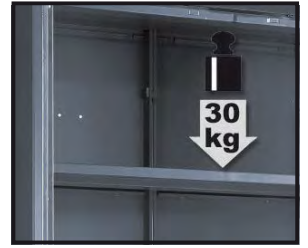

C55A1

1 055000411

## C55A1/R42

interior shelf for tool cabinet C55A1/C55AT1

1,9 kg



C55A1/R42

497x403 mm

1 055000461

## C55 A1/RB42

interior shelf for tool cabinet C55A1/C55AT1, with clothes rail

2,3 kg



C55 A1/RB42

mm  
497x403

1 055000463



# Beta



## C55A2

sheet metal two-door tool cabinet, for workshop equipment combination

- 3 removable, vertically adjustable shelves
- With lock
- Usable interior dimensions: 1798x797x403 mm

69,5 kg

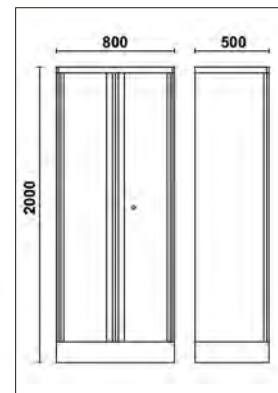

C55A2

1 055000412

## C55A2/R70

interior shelf for tool cabinet C55A2/C55AT2

3,6 kg

50 kg



C55A2/R70

700x420 mm

1 055000462

# Beta

## C55AT1

sheet metal tool cabinet with clear polycarbonate door, for workshop equipment combination

- 3 removable, vertically adjustable shelves
- With lock
- Usable interior dimensions: 1798x497x403 mm

41 kg

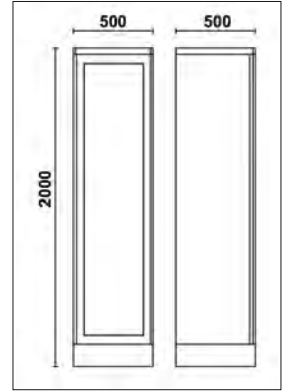

C55AT1

1 055000421

## C55AT2

sheet metal tool cabinet with two clear polycarbonate doors, for workshop equipment combination

- 3 removable, vertically adjustable shelves
- With lock
- Usable interior dimensions: 1798x797x403 mm

56 kg

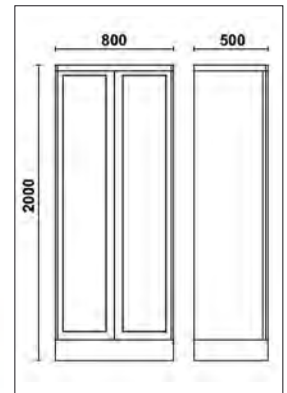

C55AT2

1 055000422

## C55STR

adhesive tape 25 m

allows to tailor the vertical tapes of garage furniture item C55



RAL2011  
RAL3000  
RAL6029  
RAL9016  
RAL1023  
RAL5015  
RAL1035  
RAL9006

C55STR-O/2011		1	055000901
C55STR-R/3000		1	055000903
C55STR-V/6029		1	055000906
C55STR-Y/1023		1	055000905
C55STR-B/5015		1	055000904
C55STR-S/9006		1	055000902





# WORKSHOP EQUIPMENT RSC50 2.0



Beta keeps evolving in line with market trends, to successfully take up the challenges of the future.

As a result, the workshop equipment combination, RSC50, has been upgraded into **the new, revolutionary system, RSC50 2.0**. The new **70-cm-long worktop**, the three types of material to choose from (sheet metal, **multi-ply wood** and **stainless steel coated MDF**) make RSC50 2.0 a one-of-a-kind ITALIAN-MADE line.

RSC50 2.0 means a perfect combination of modern design and unparalleled functionality. Designed to satisfy today's professionals' requirements.



## QUALITY

Our acclaimed care in choosing the materials, painstaking attention for detail and, last but not least, the captivating design make the RSC50 2.0 a one-of-a-kind workshop equipment range.



## FUNCTIONALITY AND STURDINESS

The **70-cm-deep worktop** means having a large, convenient, functional work surface available. It can be fitted with a vice, thereby allowing heavy-duty jobs to be carried out.



## EFFICIENCY

**Simple, quick installation**, based on the optimized production of the various parts of the range.



## FLEXIBILITY

Each workshop equipment combination can be extended or modified at any time as required. **You can choose the material of your worktop:** sheet metal, multi-ply wood or stainless steel coated MDF.



## COMPATIBILITY

The drawers in Beta's standard dimensions (588x367 mm) can accommodate the numerous tool modules, which are available in both soft and hard versions, made from EVA and ABS respectively.

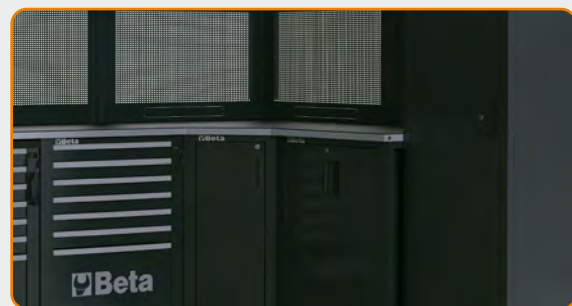
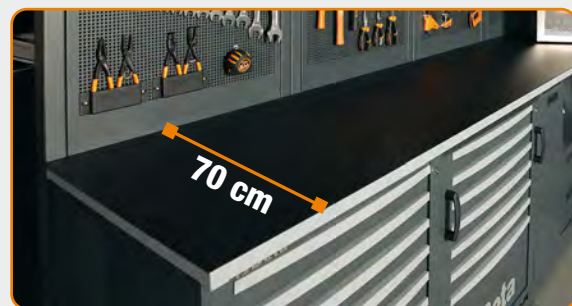



# WORKSHOP EQUIPMENT RSC50 2.0



Configure your workshop  
in 3D online on  
[www.beta-tools.com/rsc50](http://www.beta-tools.com/rsc50)

The new workshop equipment range, RSC50 2.0, comprises preassembled combinations, developed by Beta for professionals; alternatively, you can design your workplace on your own, choosing from many under-bench modules, wall-mounted cabinets and furnishing accessories.

The workshop equipment range, RSC50 2.0, comprises preassembled combinations, developed by Beta for professionals; alternatively, you can design your workplace on your own, choosing from many under-bench modules, wall-mounted cabinets and furnishing accessories.

## RSC50 2.0 I

workshop equipment combination RSC50 2.0

Combination comprising the following:

- 1 worktop, 2,240x700 mm (RSC50 2.0 NPG/3-2.2MT)
- 1 worktop, 1,495x700 mm (RSC50 2.0 NPG/2-1,5MT)
- 1 fixed module with 7 drawers (RSC50 2.0 M7)
- 1 mobile roller cab with 7 drawers (RSC50 2.0 C7)
- 1 fixed service module with 2 drawers (RSC50 2.0 MS-2C)
- 1 self-supporting complete corner (RSC50 2.0 NAC-G)
- 1 fixed module with 5 drawers (RSC50 2.0 M5)
- 1 fixed two-door module (RSC50 2.0 MA)
- 5 wall-mounted cabinets (RSC50 2.0 PM)
- 5 upper perforated tool panels (RSC50 2.0 PFS)
- 5 lower perforated tool panels (RSC50 2.0 PFI)
- 5 pairs of right/left uprights (RSC50 2.0 P/2MDX-SX)
- 2 single-door cabinets (RSC50 2.0 A1)

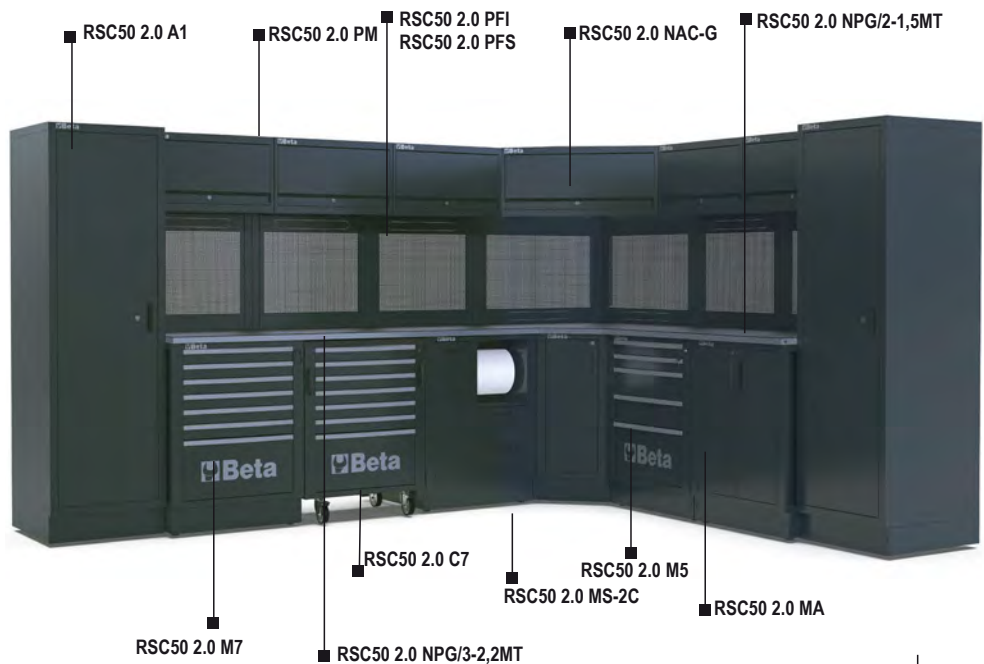

804 kg

RSC50 2.0 I

1 050001046

## RSC50 2.0 L

workshop equipment combination RSC50 2.0

Combination comprising the following:

- 1 worktop, 2,240x700 mm (RSC50 2.0 NPG/3-2.2MT)
- 1 worktop, 750x700 mm (RSC50 2.0 NPG/1-0.7MT)
- 1 fixed service module (RSC50 2.0 MS-2AVV) with compressed air hose reel item 1900S 8x10 and cable reel item 1844 15-H05/SCK (included)
- 1 mobile roller cab with 7 drawers (RSC50 2.0 C7)
- 1 fixed module with 7 drawers (RSC50 2.0 M7)
- 1 self-supporting complete corner (RSC50 2.0 NAC-G)
- 1 fixed two-door module (RSC50 2.0 MA)
- 1 tool wall system with aluminium shutter and framework (RSC50 2.0 PS)
- 2 wall-mounted cabinets (RSC50 2.0 PM)
- 2 upper perforated tool panels (RSC50 2.0 PFS)
- 2 lower perforated tool panels (RSC50 2.0 PFI)
- 2 pairs of right/left uprights (RSC50 2.0 P/2MDX-SX)
- 2 single-door cabinets (RSC50 2.0 A1)

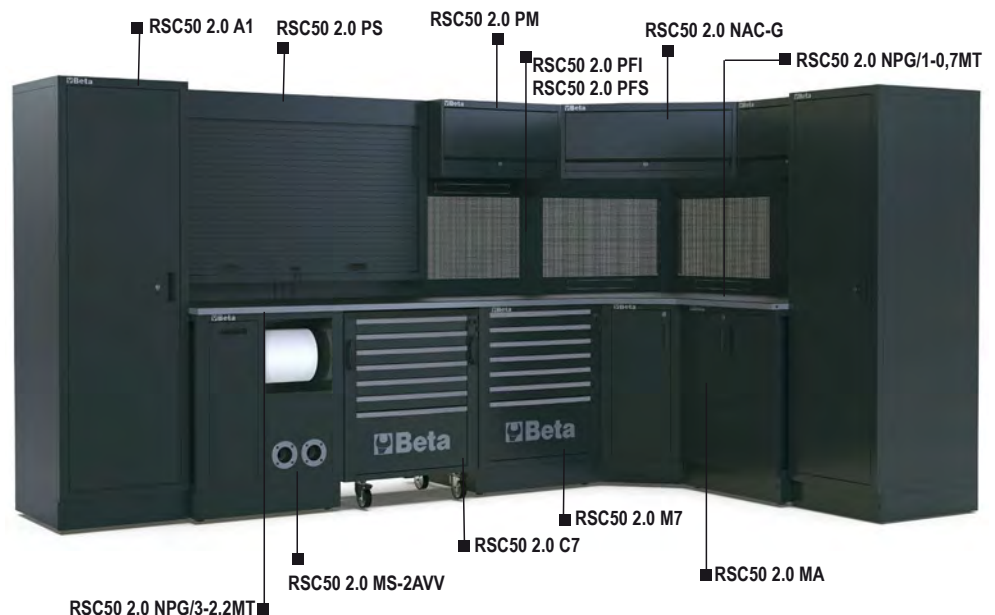

720 kg

RSC50 2.0 L

1 050001051

## RSC50 2.0

### workshop equipment combination RSC50 2.0

Combination comprising the following:

- 1 single-door cabinet (RSC50 2.0 A1)
- 1 worktop, 750x700 mm (RSC50 2.0 NPG/1-0.7MT)
- 1 worktop, 2,240x700 mm (RSC50 2.0 NPG/3-2.2MT)
- 1 mobile roller cab with 7 drawers (RSC50 2.0 C7)
- 1 fixed module with 4 drawers (RSC50 2.0 M4)
- 1 fixed module with 7 drawers (RSC50 2.0 M7)
- 1 fixed service module (RSC50 2.0 MS-AVV) with compressed air hose reel item 1900S 8x10 (included)
- 1 tool wall system with aluminium shutter and framework (RSC50 2.0 PS)
- 2 wall-mounted cabinets (RSC50 2.0 PM)
- 2 upper perforated tool panels (RSC50 2.0 PFS)
- 2 lower perforated tool panels (RSC50 2.0 PFI)
- 2 pairs of right/left uprights (RSC50 2.0 P/2MDX-SX)
- 1 two-door cabinet (RSC50 2.0 A2)

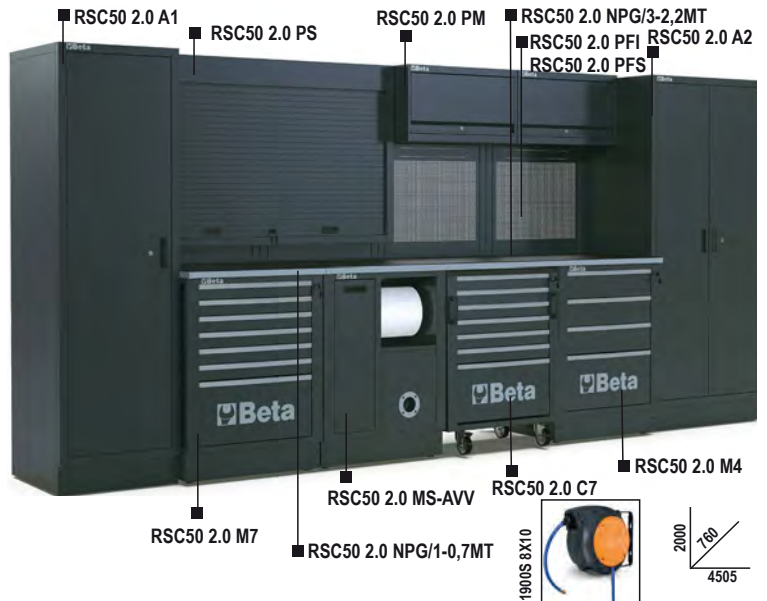

604 kg

RSC50 2.0

1 050001001

## RSC50 2.0 H

### workshop equipment combination RSC50 2.0

Combination comprising the following:

- 1 worktop, 2,240x700 mm (RSC50 2.0 NPG/3-2,2MT)
- 1 fixed service module with 2 drawers (RSC50 2.0 MS-2C)
- 1 mobile roller cab with 7 drawers (RSC50 2.0 C7)
- 1 fixed module with 7 drawers (RSC50 2.0 M7)
- 1 fixed module with built-in sink (RSC50 2.0 ML)
- 4 wall-mounted cabinets (RSC50 2.0 PM)
- 4 upper perforated tool panels (RSC50 2.0 PFS)
- 4 lower perforated tool panels (RSC50 2.0 PFI)
- 4 pairs of right/left uprights (RSC50 2.0 P/2MDX-SX)
- 1 single-door cabinet (RSC50 2.0 A1)

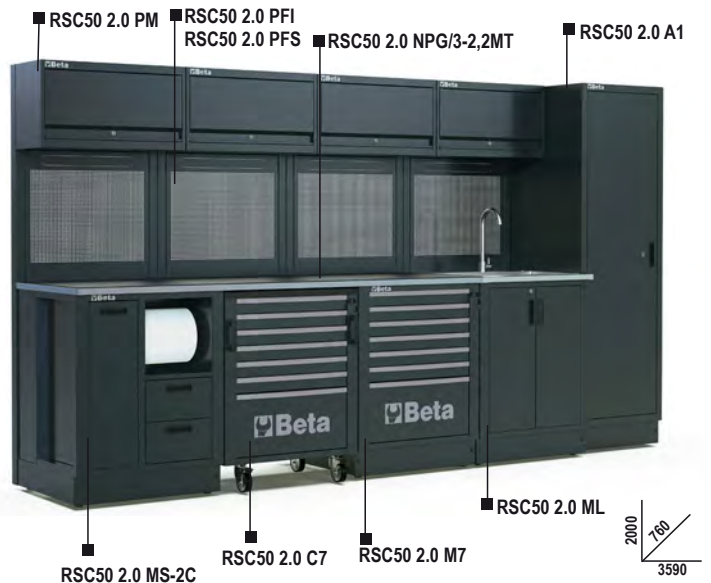

464 kg

RSC50 2.0 H

1 050001041

## RSC50 2.0 G

### workshop equipment combination RSC50 2.0

Combination comprising the following:

- 1 worktop, 2,240x700 mm (RSC50 2.0 NPG/3-2.2MT)
- 1 fixed service module (RSC50 2.0 MS-2AVV) with compressed air hose reel item 1900S 8x10 and cable reel item 1844 15-H05/SCK (included)
- 1 mobile roller cab with 7 drawers (RSC50 2.0 C7)
- 1 fixed module with 4 drawers (RSC50 2.0 M4)
- 3 wall-mounted cabinets (RSC50 2.0 PM)
- 3 upper perforated tool panels (RSC50 2.0 PFS)
- 3 lower perforated tool panels (RSC50 2.0 PFI)
- 3 pairs of right/left uprights (RSC50 2.0 P/2MDX-SX)
- 1 two-door cabinet (RSC50 2.0 A2)



416 kg

RSC50 2.0 G

1 050001036

## RSC50 2.0 F

workshop equipment combination RSC50 2.0

Combination comprising the following:

- 1 worktop, 2,240x700 mm (RSC50 2.0 NPG/3-2.2MT)
- 1 fixed module with 7 drawers (RSC50 2.0 M7)
- 1 mobile roller cab with 7 drawers (RSC50 2.0 C7)
- 1 fixed service module with 2 drawers (RSC50 2.0 MS-2C)
- 3 wall-mounted cabinets (RSC50 2.0 PM)
- 3 upper perforated tool panels (RSC50 2.0 PFS)
- 3 lower perforated tool panels (RSC50 2.0 PFI)
- 3 pairs of right/left uprights (RSC50 2.0 P/2MDX-SX)
- 1 two-door cabinet (RSC50 2.0 A2)

411 kg

RSC50 2.0 F

1 050001031

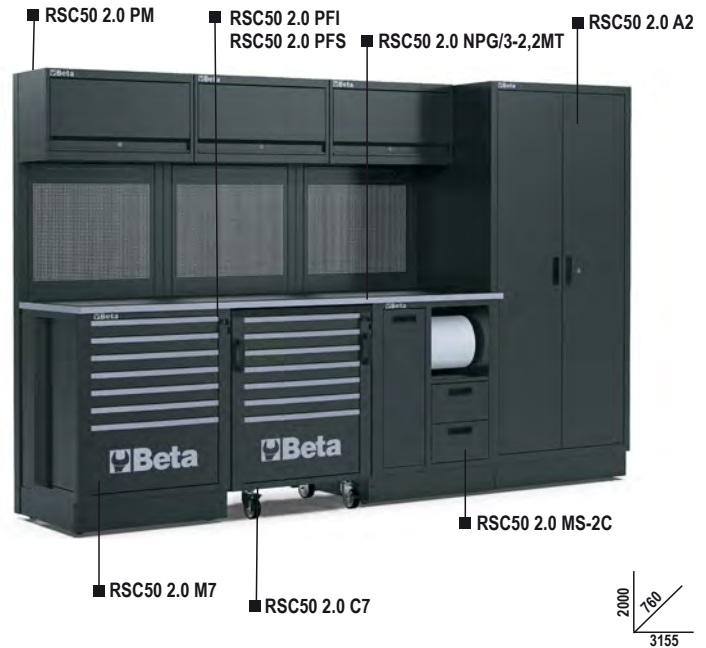

## RSC50 2.0 FX

workshop equipment combination RSC50 2.0

Combination comprising the following:

- 1 worktop (2,240x700 mm) made from stainless steel coated MDF (RSC50 2.0 PX/3-2.2MT)
- 1 fixed module with 7 drawers (RSC50 2.0 M7)
- 1 mobile roller cab with 7 drawers (RSC50 2.0 C7)
- 1 fixed service module with 2 drawers (RSC50 2.0 MS-2C)
- 3 wall-mounted cabinets (RSC50 2.0 PM)
- 3 upper perforated tool panels (RSC50 2.0 PFS)
- 3 lower perforated tool panels (RSC50 2.0 PFI)
- 3 pairs of right/left uprights (RSC50 2.0 P/2MDX-SX)
- 1 two-door tool cabinet (RSC50 2.0 A2)

405 kg

RSC50 2.0 FX

1 050001032



## RSC50 2.0 FW

workshop equipment combination RSC50 2.0

Combination comprising the following:

- 1 worktop (2,240x700 mm) made from multi-ply wood (RSC50 2.0 PW/3-2.2MT)
- 1 fixed module with 7 drawers (RSC50 2.0 M7)
- 1 mobile roller cab with 7 drawers (RSC50 2.0 C7)
- 1 fixed service module with 2 drawers (RSC50 2.0 MS-2C)
- 3 wall-mounted cabinets (RSC50 2.0 PM)
- 3 upper perforated tool panels (RSC50 2.0 PFS)
- 3 lower perforated tool panels (RSC50 2.0 PFI)
- 3 pairs of right/left uprights (RSC50 2.0 P/2MDX-SX)
- 1 two-door tool cabinet (RSC50 2.0 A2)

386 kg

RSC50 2.0 FW

1 050001033

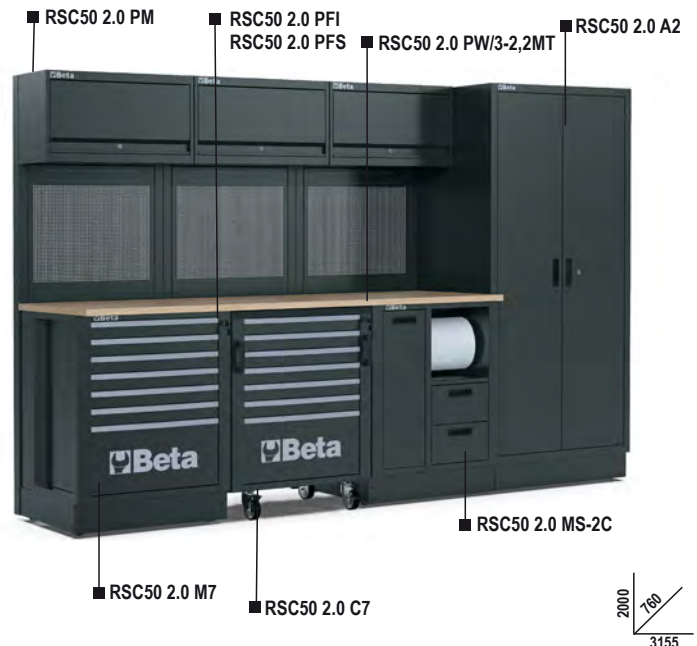

## RSC50 2.0 E

workshop equipment combination RSC50 2.0

Combination comprising the following:

- 1 worktop, 2,240x700 mm (RSC50 2.0 NPG/3-2.2MT)
- 1 fixed service module with 2 drawers (RSC50 2.0 MS-2C)
- 1 fixed module with 7 drawers (RSC50 2.0 M7)
- 1 fixed two-door module (RSC50 2.0 MA)
- 3 wall-mounted cabinets (RSC50 2.0 PM)
- 3 upper perforated tool panels (RSC50 2.0 PFS)
- 3 lower perforated tool panels (RSC50 2.0 PFI)
- 3 pairs of right/left uprights (RSC50 2.0 P/2MDX-SX)

310 kg

RSC50 2.0 E

1 050001026



## RSC50 2.0 D

workshop equipment combination RSC50 2.0

Combination comprising the following:

- 1 worktop, 1,495x700 mm (RSC50 2.0 NPG/2-1.5MT)
- 1 fixed module with 5 drawers (RSC50 2.0 M5)
- 1 fixed two-door module (RSC50 2.0 MA)
- 2 wall-mounted cabinets (RSC50 2.0 PM)
- 2 upper perforated tool panels (RSC50 2.0 PFS)
- 2 lower perforated tool panels (RSC50 2.0 PFI)
- 2 pairs of right/left uprights (RSC50 2.0 P/2MDX-SX)
- 1 single-door cabinet (RSC50 2.0 A1)

276 kg

RSC50 2.0 D

1 050001021

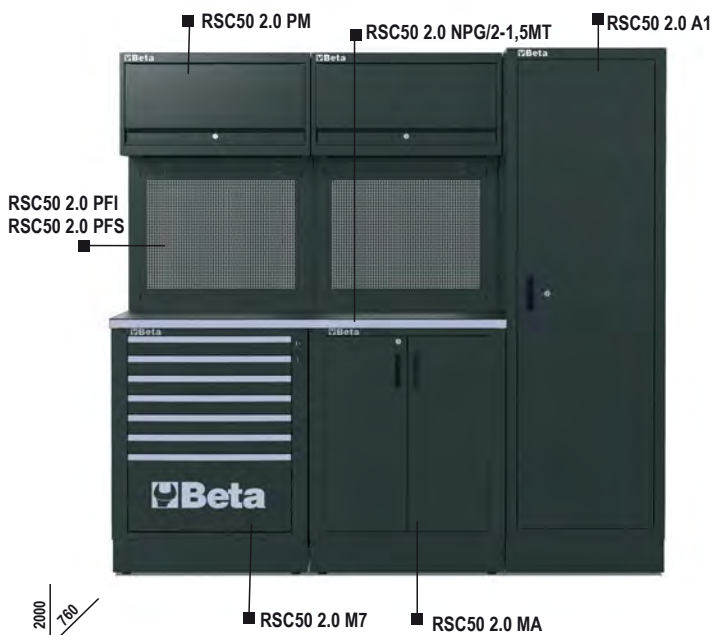

## RSC50 2.0 DX

workshop equipment combination RSC50 2.0

Combination comprising the following:

- 1 worktop (1,495x700 mm) made from stainless steel coated MDF (RSC50 2.0 PX/2-1.5MT)
- 1 fixed module with 7 drawers (RSC50 2.0 M7)
- 1 fixed two-door module (RSC50 2.0 MA)
- 2 wall-mounted cabinets (RSC50 2.0 PM)
- 2 upper perforated tool panels (RSC50 2.0 PFS)
- 2 lower perforated tool panels (RSC50 2.0 PFI)
- 2 pairs of right/left uprights (RSC50 2.0 P/2MDX-SX)
- 1 one-door tool cabinet (RSC50 2.0 A1)

275 kg

RSC50 2.0 DX

1 050001023



## RSC50 2.0 DW

workshop equipment combination RSC50 2.0

Combination comprising the following:

- 1 worktop (1,495x700 mm) made from multi-ply wood (RSC50 2.0 PW/2-1.5MT)
- 1 fixed module with 7 drawers (RSC50 2.0 M7)
- 1 fixed two-door module (RSC50 2.0 MA)
- 2 wall-mounted cabinets (RSC50 2.0 PM)
- 2 upper perforated tool panels (RSC50 2.0 PFS)
- 2 lower perforated tool panels (RSC50 2.0 PFI)
- 2 pairs of right/left uprights (RSC50 2.0 P/2MDX-SX)
- 1 one-door tool cabinet (RSC50 2.0 A1)

263 kg

RSC50 2.0 DW

1 050001024

2000  
700  
2095



## RSC50 2.0 C

workshop equipment combination RSC50 2.0

Combination comprising the following:

- 1 worktop, 1,495x700 mm (RSC50 2.0 NPG/2-1.5MT)
- 1 fixed service module with 2 drawers (RSC50 2.0 MS-2C)
- 1 fixed module with 7 drawers (RSC50 2.0 M7)
- 2 wall-mounted cabinets (RSC50 2.0 PM)
- 2 upper perforated tool panels (RSC50 2.0 PFS)
- 2 lower perforated tool panels (RSC50 2.0 PFI)
- 2 pairs of right/left uprights (RSC50 2.0 P/2MDX-SX)
- 1 single-door cabinet (RSC50 2.0 A1)

279 kg

RSC50 2.0 C

1 050001016

2000  
700  
2095

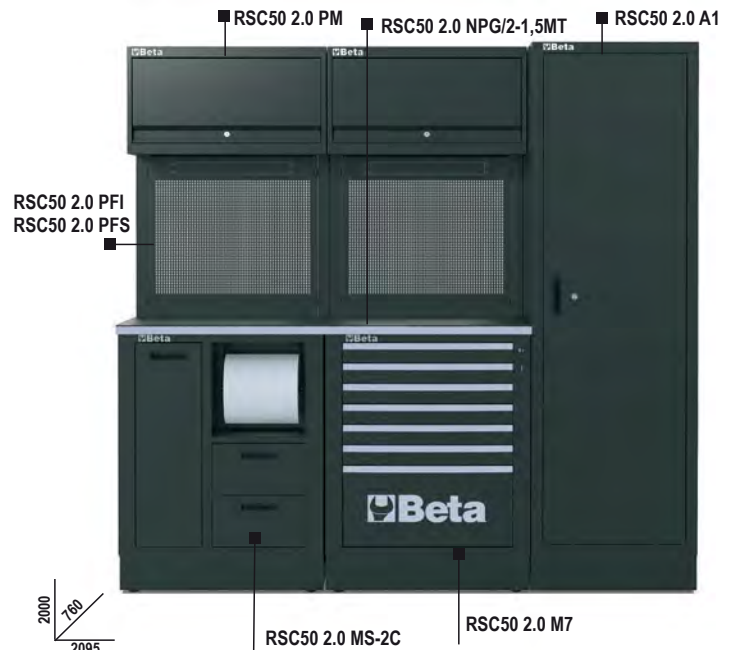

## RSC50 2.0 B

workshop equipment combination RSC50 2.0

Combination comprising the following:

- 1 worktop, 1,495x700 mm (RSC50 2.0 NPG/2-1.5MT)
- 1 fixed two-door module (RSC50 2.0 MA)
- 1 fixed module with 7 drawers (RSC50 2.0 M7)
- 1 tool wall system with aluminium shutter and framework (RSC50 2.0 PS)

224 kg

RSC50 2.0 B

1 050001011

2000  
700  
1495

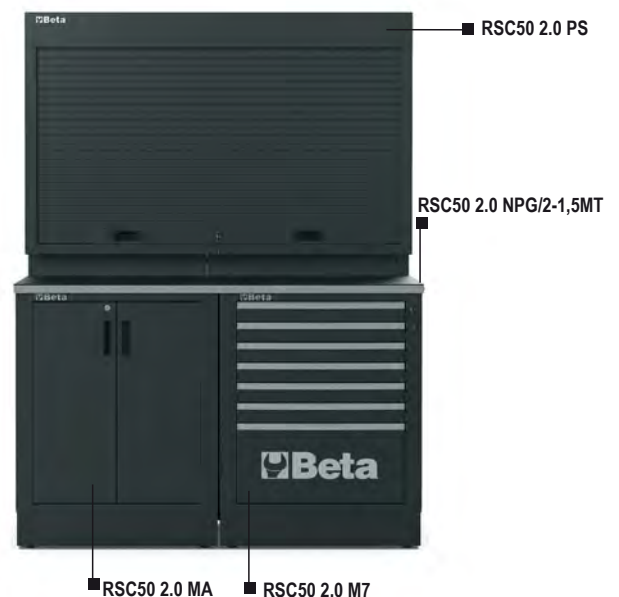

## RSC50 2.0 A

workshop equipment combination RSC50 2.0

Combination comprising the following:

- 1 worktop, 1,495x700 mm (RSC50 2.0 NPG/2-1.5MT)
- 1 fixed module with 7 drawers (RSC50 2.0 M7)
- 1 fixed service module with 2 drawers (RSC50 2.0 MS-2C)
- 2 wall-mounted cabinets (RSC50 2.0 PM)
- 2 upper perforated tool panels (RSC50 2.0 PFS)
- 2 lower perforated tool panels (RSC50 2.0 PFI)
- 2 pairs of right/left uprights (RSC50 2.0 P/2MDX-SX)

212 kg

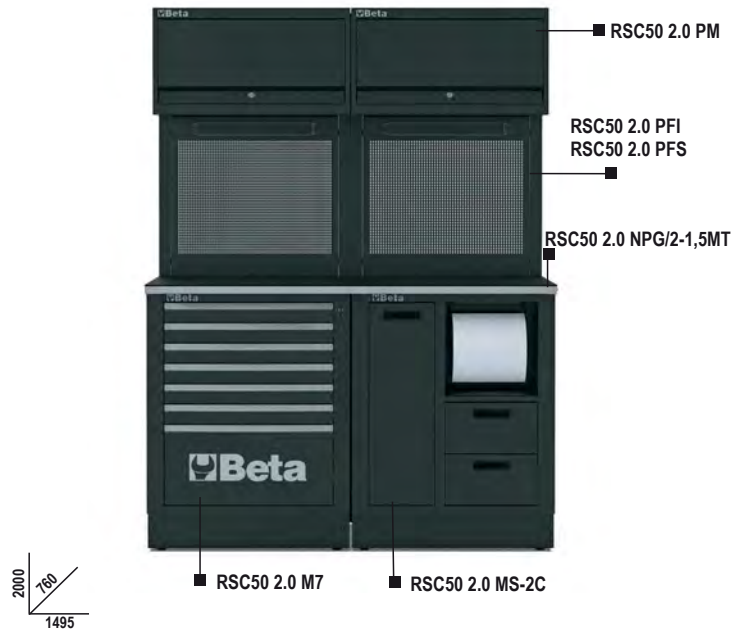

RSC50 2.0 A

1 050001006

## RSC50 2.0 NP/1-0,7MT

worktop made from sheet metal, 0.75 m long, for workbench, for workshop equipment combination RSC50 2.0

Worktop (750x700 mm) made from painted sheet metal covered with a shockproof, non-scratch PVC coat, resistant to hydrocarbons. Supplied complete with two exterior side pads.

Holes on both sides for a vice (1599P/125, to be ordered separately). Designed for application of aluminium profiles with LED strip item 5000 RSC50 2.0/PLEDC or 5000 RSC50 2.0/PLED-ST (to be ordered separately), to light under-workbench modules.

16,7 kg

RSC50 2.0 NPA/1-0,7MT

1 050001117

RSC50 2.0 NPG/1-0,7MT

1 050001118

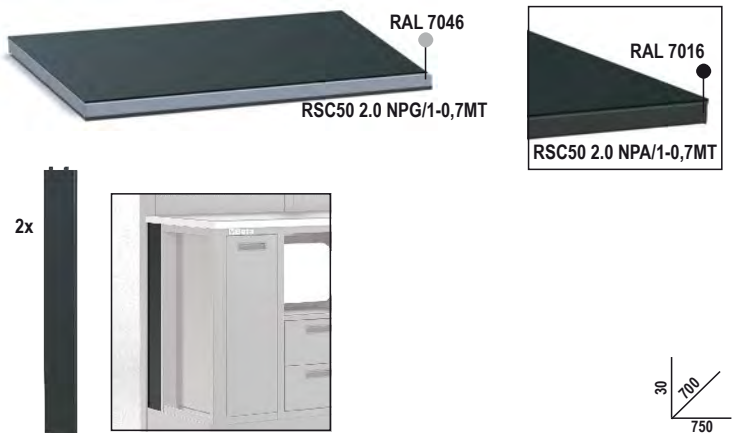

## RSC50 2.0 NP/2-1,5MT

worktop made from sheet metal, 1.5 m long, for workbench, for workshop equipment combination RSC50 2.0

Worktop (1,495x700 mm) made from painted sheet metal covered with a shockproof, non-scratch PVC coat, resistant to hydrocarbons. Supplied complete with two side pads.

Holes on both sides for a vice (1599P/125, to be ordered separately). Designed for application of aluminium profiles with LED strip item 5000 RSC50 2.0/PLEDC or 5000 RSC50 2.0/PLED-ST (to be ordered separately), to light under-workbench modules.

31 kg

RSC50 2.0 NPA/2-1,5MT

1 050001124

RSC50 2.0 NPG/2-1,5MT

1 050001125

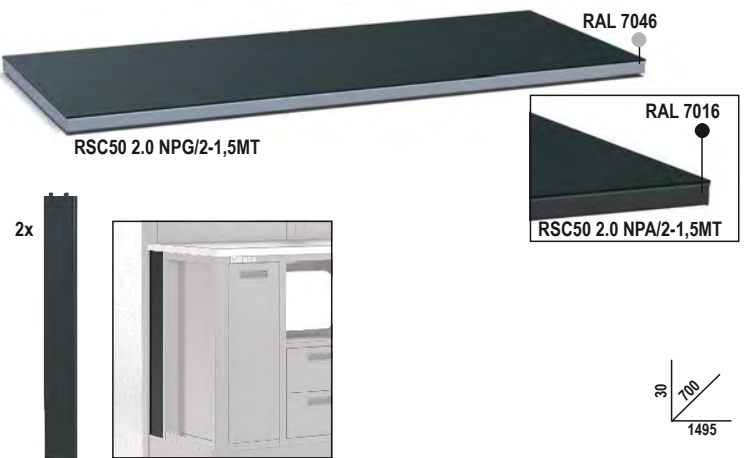

## RSC50 2.0 NP/3-2,2MT

worktop made from sheet metal, 2.2 m long,  
for workbench, for workshop equipment combination RSC50 2.0

Worktop (2,240x700 mm) made from painted sheet metal covered with a shockproof, non-scratch PVC coat, resistant to hydrocarbons. Supplied complete with two exterior side pads.

Holes on both sides for a vice (1599P/125, to be ordered separately). Designed for application of aluminium profiles with LED strip item 5000 RSC50 2.0/PLEDC or 5000 RSC50 2.0/PLED-ST (to be ordered separately), to light under-workbench modules.

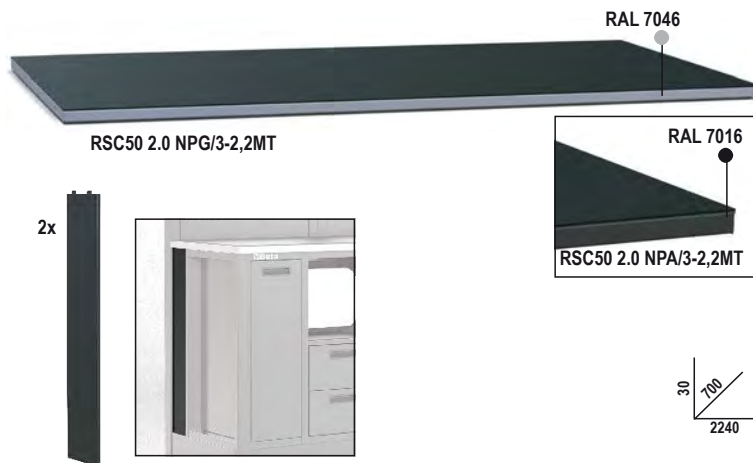

49,6 kg

RSC50 2.0 NPA/2-2,2MT	1	050001132
RSC50 2.0 NPG/2-2,2MT	1	050001133

## RSC50 2.0 PW/1-0,7MT

worktop made from multi-ply wood, 0.75 m long,  
for workbench, for workshop equipment combination RSC50 2.0

Worktop (750x700 mm) made from multi-ply wood. Supplied complete with two exterior side pads.

Can accommodate a vice (1599P/125, to be ordered separately)

7 kg

RSC50 2.0 PW/1-0,7MT	1	050001126
----------------------	---	-----------



## RSC50 2.0 PX/1-0,7MT

worktop made from stainless steel coated MDF, 0.75 m long,  
for workbench,  
for workshop equipment combination RSC50 2.0

Worktop (750x700 mm) made from stainless steel coated MDF. Supplied complete with two exterior side pads.

Can accommodate a vice (1599P/125, to be ordered separately)

13,5 kg

RSC50 2.0 PX/1-0,7MT	1	050001127
----------------------	---	-----------



## RSC50 2.0 PW/2-1,5MT

worktop made from multi-ply wood, 1.5 m long,  
for workbench, for workshop equipment combination RSC50 2.0

Worktop (1,495x700 mm) made from multi-ply wood. Supplied complete with two exterior side pads.

Can accommodate a vice (1599P/125, to be ordered separately)

14,5 kg

RSC50 2.0 PW/2-1,5MT	1	050001130
----------------------	---	-----------



## RSC50 2.0 PX/2-1,5MT

worktop made from stainless steel coated MDF, 1.5 m long, for  
workshop equipment combination RSC50 2.0

Worktop (1,495x700 mm) made from stainless steel coated MDF. Supplied complete with two exterior side pads.

Can accommodate a vice (1599P/125, to be ordered separately)

27 kg

RSC50 2.0 PX/2-1,5MT	1	050001131
----------------------	---	-----------



## RSC50 2.0 PW/3-2,2MT

worktop made from multi-ply wood, 2.2 m long, for workbench, for workshop equipment combination RSC50 2.0

Worktop (2,240x700 mm) made from multi-ply wood  
Supplied complete with two exterior side pads.



Can accommodate a vice (1599P/125, to be ordered separately)

21 kg

RSC50 2.0 PW/3-2,2MT

1 050001136

## RSC50 2.0 PX/3-2,2MT

worktop made from stainless steel coated MDF, 2.2 m long, for workbench, for workshop equipment combination RSC50 2.0

Worktop (2,240x700 mm) made from stainless steel coated MDF.  
Supplied complete with two exterior side pads.



Can accommodate a vice (1599P/125, to be ordered separately)

40,5 kg

RSC50 2.0 PX/3-2,2MT

1 050001137

## RSC50 2.0 RB

shock-proof, non-scratch PVC coat, resistant to hydrocarbons, for workshop equipment combination RSC50

A must-have for protecting worktops.

RSC50 RB/0.63: for corner worktop, 630x630 mm

RSC50 RB/0.75: for 750-mm-long worktop

RSC50 RB/1.5: for 1,495-mm-long worktop

RSC50 RB/2.2: for 2,240-mm-long worktop



RSC50 RB/0,63

1 050001140

RSC50 RB/0,75

1 050001141

RSC50 RB/1,5

1 050001142

RSC50 RB/2,2

1 050001143

## RSC50 2.0 C5

mobile roller cab with 5 drawers, for workshop equipment combination RSC50 2.0

- 5 drawers (588x367 mm) with ball bearing slides
- 4 swivel castors, Ø 100 mm (2 with brakes)
- Drawer bases protected by foamed rubber mats
- Front centralized lock
- Handles built into frame for improved ease of handling
- Each drawer can accommodate up to 4 EVA foam or ABS thermoformed trays

58 kg

RSC50 2.0 C5

1 050001205

h	max
70 mm	25 kg
140 mm	30 kg
280 mm	35 kg

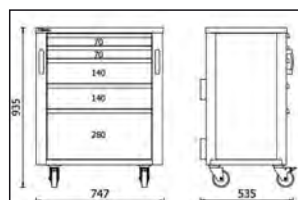
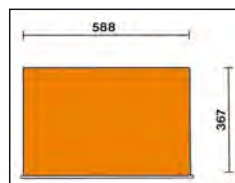

800 kg



## RSC50 2.0 C6

mobile roller cab with 6 drawers, for workshop equipment combination  
RSC50 2.0

- 6 drawers (588x367 mm) with ball bearing slides
- 4 steering castors, Ø 100 mm (2 with brakes)
- Drawer bases protected by foamed rubber mats
- Front centralized lock
- Handles built into frame for improved ease of handling
- Each drawer can accommodate up to 4 EVA foam or ABS thermoformed trays

61 kg

h	max
70 mm	25 kg
140 mm	30 kg
280 mm	35 kg

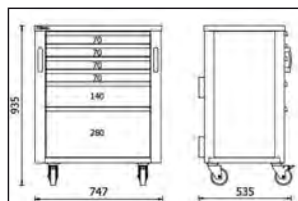
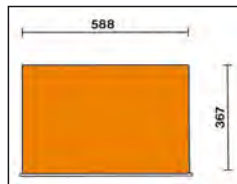

800 kg



RSC50 2.0 C6

1 050001206

## RSC50 2.0 C7

mobile roller cab with 7 drawers, for workshop equipment combination  
RSC50 2.0

- 7 drawers (588x367 mm) with ball bearing slides
- 4 swivel castors, Ø 100 mm (2 with brakes)
- Drawer bases protected by foamed rubber mats
- Front centralized lock
- Handles built into frame for improved ease of handling
- Each drawer can accommodate up to 4 EVA foam or ABS thermoformed trays

62 kg

h	max
70 mm	25 kg
280 mm	35 kg

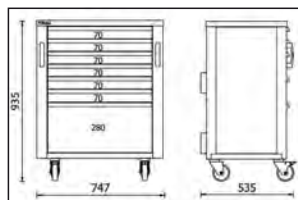
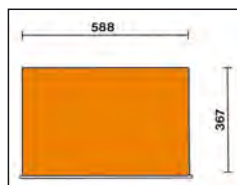

800 kg



RSC50 2.0 C7

1 050001207

**Beta**

## RSC50 2.0 C8

mobile roller cab with 8 drawers, for workshop equipment combination  
RSC50 2.0

- 8 drawers (588x367 mm) with ball bearing slides
- 4 swivel castors, Ø 100 mm (2 with brakes)
- Drawer bases protected by foamed rubber mats
- Front centralized lock
- Handles built into frame for improved ease of handling
- Each drawer can accommodate up to 4 EVA foam or ABS thermoformed trays

64 kg

h	max
70 mm	25 kg
140 mm	30 kg

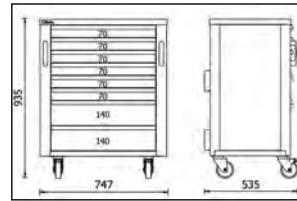
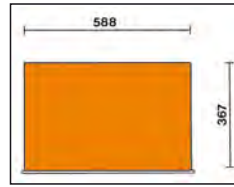

800 kg



RSC50 2.0 C8

1 050001208

## RSC50 2.0 M4

fixed module with 4 drawers, for workshop equipment combination  
RSC50 2.0

- 4 drawers (588x367 mm) with ball bearing slides
- Drawer bases protected by foamed rubber mats
- Front centralized lock
- With vertically adjustable feet
- Each drawer can accommodate up to 4 EVA foam or ABS thermoformed trays

61,5 kg

h	max
140 mm	30 kg
280 mm	35 kg

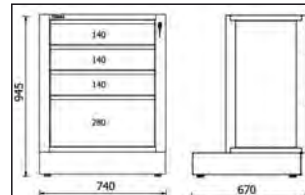
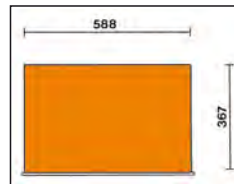

RSC50 2.0 M4

1 050001264

## RSC50 2.0 M5

fixed module with 5 drawers, for workshop equipment combination  
RSC50 2.0

- 5 drawers (588x367 mm) with ball bearing slides
- Drawer bases protected by foamed rubber mats
- Front centralized lock
- With vertically adjustable feet
- Each drawer can accommodate up to 4 EVA foam or ABS thermoformed trays

63,5 kg

h	max
70 mm	25 kg
140 mm	30 kg
280 mm	35 kg

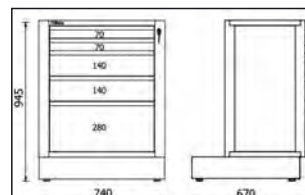
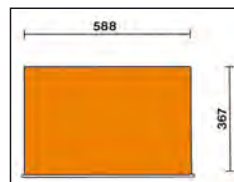

RSC50 2.0 M5

1 050001265

## RSC50 2.0 M6

fixed module with 6 drawers, for workshop equipment combination  
RSC50 2.0

- 6 drawers (588x367 mm) with ball bearing slides
- Drawer bases protected by foamed rubber mats
- Front centralized lock
- With vertically adjustable feet
- Each drawer can accommodate up to 4 EVA foam or ABS thermoformed trays

65,5 kg

h	max
70 mm	25 kg
140 mm	30 kg
280 mm	35 kg

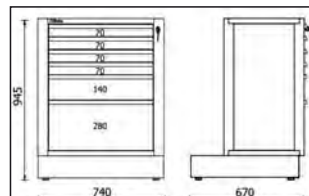
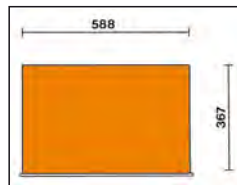

RSC50 2.0 M6

1 050001226

## RSC50 2.0 M7

fixed module with 7 drawers, for workshop equipment combination  
RSC50 2.0

- 7 drawers (588x367 mm) with ball bearing slides
- Drawer bases protected by foamed rubber mats
- Front centralized lock
- With vertically adjustable feet
- Each drawer can accommodate up to 4 EVA foam or ABS thermoformed trays

67,5 kg

h	max
70 mm	25 kg
280 mm	35 kg

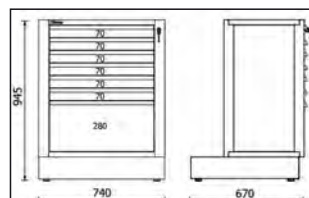
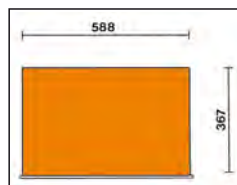

RSC50 2.0 M7

1 050001267

## RSC50 2.0 M8

fixed module with 8 drawers, for workshop equipment combination  
RSC50 2.0

- 8 drawers (588x367 mm) with ball bearing slides
- Drawer bases protected by foamed rubber mats
- Front centralized lock
- With vertically adjustable feet
- Each drawer can accommodate up to 4 EVA foam or ABS thermoformed trays

69,5 kg

h	max
70 mm	25 kg
140 mm	30 kg

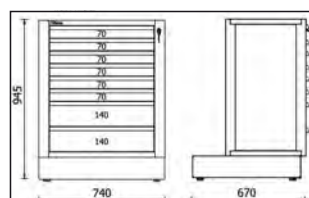
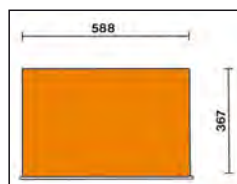

RSC50 2.0 M8

1 050001268

## RSC50 2.0 M10

fixed module with 10 drawers, for workshop equipment combination RSC50 2.0

- 10 drawers (588x367 mm) with ball bearing slides
- Drawer bases protected by foamed rubber mats
- Front centralized lock
- With vertically adjustable feet
- Each drawer can accommodate up to 4 EVA foam or ABS thermoformed trays

h	max
70 mm	25 kg

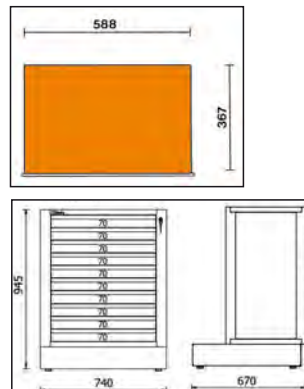

76 kg

RSC50 2.0 M10

1 050001231

## RSC50 2.0 MS-2C

fixed service module, for workshop equipment combination RSC50 2.0

- Built-in waste bin
- Paper roll compartment
- Two drawers, 310x370 mm, 180 mm high, with ball bearing slides (interior dimensions)
- With vertically adjustable feet

49 kg

RSC50 2.0 MS-2C

1 050001283

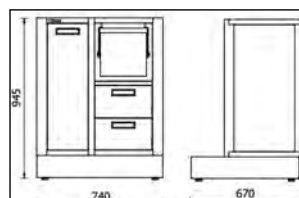

## RSC50 2.0 MS-AVV

fixed service module, for workshop equipment combination RSC50 2.0, empty

Can accommodate one reel, to be chosen from the following models:

- compressed air hose reel item 1900S 8x10
- cable reels items 1843 15-H05, 1844 10-H05, 1844 15-H05, 1844 15-H07, 1844 15-H05/SCK, 1844 15-H07/SCK, 1845 12-H05, 1846 10-H05, 1846 10-H07 and 1846 15-H05

- Built-in waste bin
- Paper roll compartment
- With vertically adjustable feet

49 kg

RSC50 2.0 MS-AVV

1 050001281

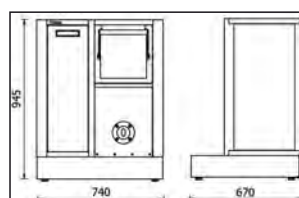

## RSC50 2.0 MS-2AVV

fixed service module, for workshop equipment combination RSC50 2.0, empty

Can accommodate two reels, to be chosen from the following models:

- compressed air hose reel item 1900S 8x10
- cable reels items 1843 15-H05, 1844 10-H05, 1844 15-H05, 1844 15-H07, 1844 15-H05/SCK, 1844 15-H07/SCK, 1845 12-H05, 1846 10-H05, 1846 10-H07 and 1846 15-H05

- Built-in waste bin
- Paper roll compartment
- With vertically adjustable feet

50 kg

RSC50 2.0 MS-2AVV

1 050001282

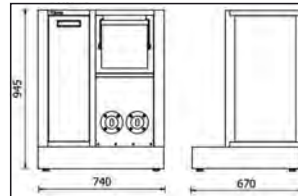

## RSC50 2.0 MA

fixed two-door module, for workshop equipment combination RSC50 2.0

- With lock
- Vertically adjustable interior shelf
- Interior dimensions: 615x435x740 mm
- With vertically adjustable feet

46 kg

RSC50 2.0 MA

1 050001262

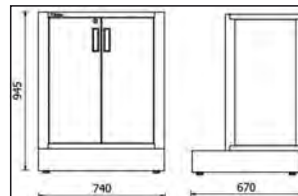

## RSC50 2.0 CS

fixed sorted waste collection module, for workshop equipment combination RSC50 2.0

- Pull-out waste compartment (588x355x580 mm) with ball bearing slides
- 2 capacious pull-out interior containers for sorting waste
- With vertically adjustable feet

48 kg

RSC50 2.0 CS

1 050001285

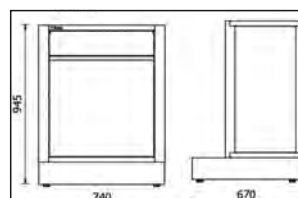

## RSC50 2.0 ML

fixed module with built-in sink, for workshop equipment combination  
RSC50 2.0

Technical specifications:

- Stainless steel basin
- Supplied complete with:
  - 1 mixer tap
  - 1 drain unit
  - 1 sink stopper
  - 1 filter cap
  - 1 soap dispenser

Fixed two-door module with lock:

- Usable interior dimensions: 615x435x575 mm
- With vertically adjustable feet

39 kg

RSC50 2.0 ML



050001284

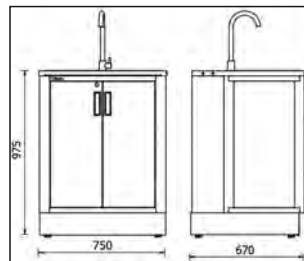

## RSC50 2.0 MDO

fixed oil distribution module for workshop equipment combination  
RSC50 2.0

- 2 hose reels 7 m - 1/2" included
- Complete with 2 guns with digital litre counter and automatic drip catcher.
  - Max. flow rate: 30 l/min
  - Viscosity: 8÷2000 mPas
- With vertically adjustable feet

92 kg

RSC50 2.0 MDO



050001290

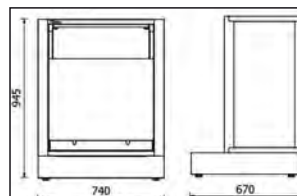

## RSC50 2.0 T3

3-tier tool trolley, for workshop equipment combination RSC50 2.0

- 4 swivel castors, Ø 100 mm (two with brakes)
- Static load capacity: 200 kg (distributed over 3 shelves)

23 kg

RSC50 2.0 T3



050001253

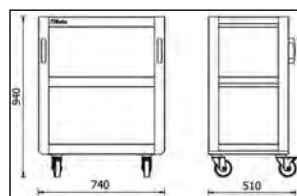

## RSC50 2.0 KPF

kit of perforated tool panels, for workshop equipment combination RSC50 2.0

Kit contents:

- One upper perforated tool panel, 650x400x25 mm
- One lower perforated tool panel, 650x625x25 mm, can accommodate a 19" rack multi-socket (not included)
- One pair of right/left uprights

17,5 kg

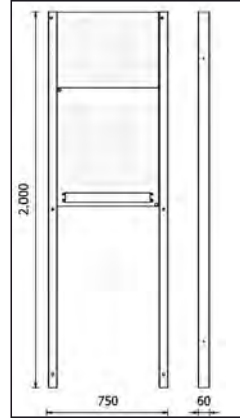

RSC50 2.0 KPF



## RSC50 2.0 PFS

upper perforated tool panel, for workshop equipment combination RSC50 2.0

- Perforated tool panel, 650x400x25 mm

3 kg

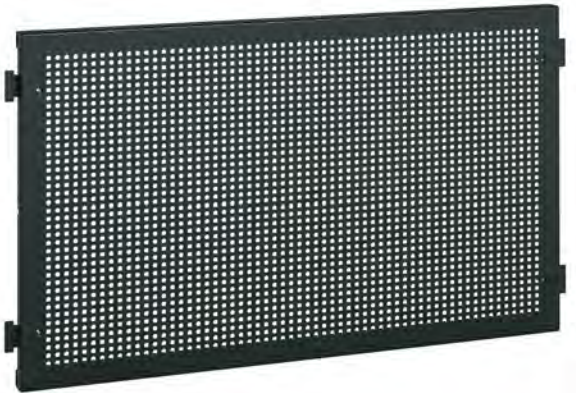

RSC50 2.0 PFS



## RSC50 2.0 PFI

lower perforated tool panel, for workshop equipment combination RSC50 2.0

- Lower perforated tool panel, 650x625x25 mm
- Can accommodate a 19" rack multi-socket (not included)

4,5 kg



RSC50 2.0 PFI



## RSC50 2.0 P/2MDX-SX

pair of right/left uprights for perforated tool wall systems, for workshop equipment combination RSC50 2.0

8,5 kg

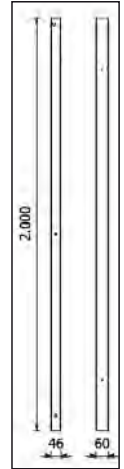

RSC50 2.0 P/2MDX-SX

1 050001352

## RSC50 2.0 PM

wall-mounted cabinet, for workshop equipment combination RSC50 2.0

- Dimensions: 740x300x400 mm
- Fitted with gas springs, making it easier to open and close door
- Designed for application of aluminium profiles with LED strip item 5000 RSC50 2.0/PLEDC or 5000 RSC50 2.0/PLED-ST (to be ordered separately), to light working area beneath and/or interior of suspended cabinet.

15 kg



30 kg

RSC50 2.0 PM

1 050001302

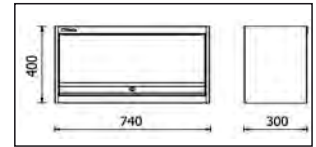

## RSC50 2.0 MTP

triangular shelf, for workshop equipment combination RSC50 2.0

- Dimensions: 740x300x400 mm
- Designed for application of aluminium profiles with LED strip item 5000 RSC50 2.0/PLEDC or 5000 RSC50 2.0/PLED-ST (to be ordered separately), to light working area beneath

5 kg



10 kg

RSC50 2.0 MTP

1 050001305



# Beta



## RSC50 2.0 PS

tool wall system with shutter, for workshop equipment combination  
RSC50 2.0

- Aluminium shutter, vertically adjustable, with lock
- Removable perforated tool panels
- Supplied with framework
- 50-hook GPS kit included

80 kg

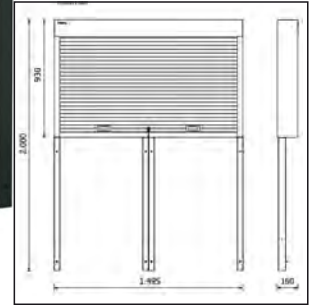

RSC50 2.0 PS

1 050001360

## RSC50 2.0 NAC

self-supporting complete corner, for workshop equipment combination  
RSC50 2.0

- Corner worktop (964x964) made from painted sheet metal covered with a shockproof, non-scratch PVC coat, resistant to hydrocarbons
- Suspended corner cabinet with lock and gas springs, making it easier to open and close door
- 2 perforated tool panels (869x1,027 mm)
- Lower corner module with large storage compartment
- With vertically adjustable feet

143 kg



RSC50 2.0 NAC-A

RAL 7016



RAL 7046

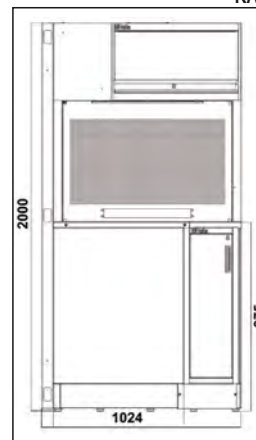

RSC50 2.0 NAC-G

RSC50 2.0 NAC-A

1 050001339

RSC50 2.0 NAC-G

1 050001340



**Beta**

## RSC50 2.0 NAC-W

self-supporting complete corner, for workshop equipment combination RSC50 2.0

- Corner worktop (964x964 mm) made from multi-ply wood
- Suspended corner cabinet with lock and gas springs, making it easier to open and close door
- 2 perforated tool panels (869x1,027 mm)
- Lower corner module with large storage compartment
- With vertically adjustable feet

139 kg

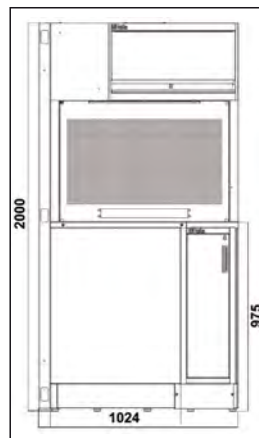

RSC50 2.0 NAC-W

RSC50 2.0 NAC-W

1 050001327

## RSC50 2.0 NAC-X

self-supporting complete corner, for workshop equipment combination RSC50 2.0

- Corner worktop (964x964 mm) made from stainless steel coated MDF
- Suspended corner cabinet with lock and gas springs, making it easier to open and close door
- 2 perforated tool panels (869x1,027 mm)
- Lower corner module with large storage compartment
- With vertically adjustable feet

148 kg

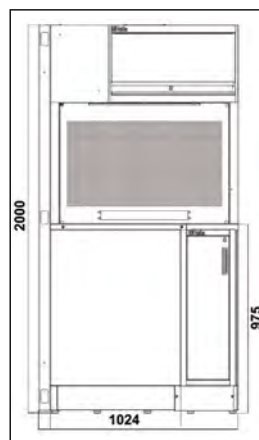

RSC50 2.0 NAC-X

RSC50 2.0 NAC-X

1 050001328

## RSC50 2.0 KNAI

lower corner module, for workshop equipment combination RSC50 2.0

- Worktop (964x964 mm) made from painted sheet metal covered with a shockproof, non-scratch PVC coat, resistant to hydrocarbons
- Fixed corner module with large storage compartment
- With vertically adjustable feet

80 kg

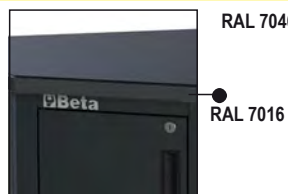

RSC50 2.0 KNAI-A

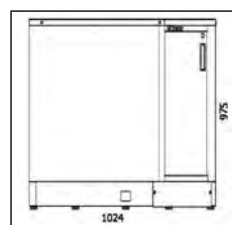

RSC50 2.0 KNAI-G

RSC50 2.0 KNAI-A

1 050001345

RSC50 2.0 KNAI-G

1 050001346

## RSC50 2.0 KNAI-W

lower corner module, for workshop equipment combination RSC50 2.0

- Corner worktop (964x964 mm) made from multi-ply wood
- Fixed corner module with large storage compartment
- With vertically adjustable feet

76 kg

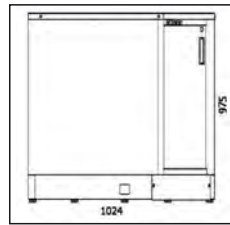

RSC50 2.0 KNAI-W

RSC50 2.0 KNAI-W

1 050001337

## RSC50 2.0 KNAI-X

lower corner module, for workshop equipment combination RSC50 2.0

- Corner worktop (964x964 mm) made from stainless steel coated MDF
- Fixed corner module with large storage compartment
- With vertically adjustable feet

85 kg

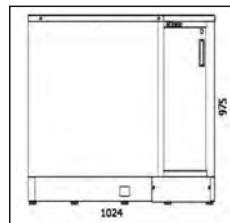

RSC50 2.0 KNAI-X

RSC50 2.0 KNAI-X

1 050001338

## RSC50 2.0 A1

sheet metal single-door tool cabinet, for workshop equipment combination RSC50 2.0

- 4 removable, vertically adjustable shelves
- Convenient folding clothes rail under first shelf
- With lock
- Interior dimensions: 590x615 mm
- With vertically adjustable feet

67 kg

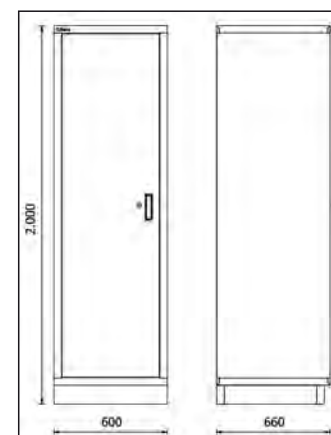

RSC50 2.0 A1

1 050001411

## RSC50 2.0 A1/R59

interior shelf for tool cabinet RSC50 A1

3,1 kg



RSC50 2.0 A1/R59 605x596 mm

1 050001913

## RSC50 2.0 A1/RB59

interior shelf for tool cabinet RSC50 A1, with clothes rail

3,4 kg

RSC50 2.0 A1/RB59 605x596 mm

1 050001914

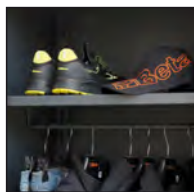

## RSC50 2.0 A2

sheet metal two-door tool cabinet, for workshop equipment combination RSC50 2.0

- 4 removable, vertically adjustable shelves
- With lock
- Interior dimensions: 910x615 mm
- With vertically adjustable feet

85 kg

RSC50 2.0 A2

1 050001412



## RSC50 2.0 A2/3C

sheet metal two-door tool cabinet with 3 drawers, for workshop equipment combination RSC50 2.0

- 4 removable, vertically adjustable shelves
- **Supplied complete with 3-drawer (681x360 mm) module**
- Front lock
- Interior dimensions: 910x615 mm
- With vertically adjustable feet

105,50 kg

RSC50 2.0 A2/3C

1 050001413

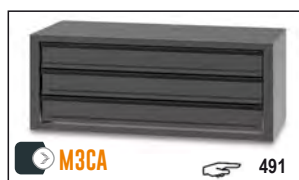

## RSC50 2.0 A2/R91

interior shelf for tool cabinet RSC50 A2

4,2 kg

RSC50 2.0 A2/R91 911x596 mm

1 050001915



## 5000 RSC50 2.0/MP

shelf, for workshop equipment combination RSC50 2.0

- Dimensions: 740x140x80 mm
- Designed for application of aluminium profiles with LED strip item 5000 RSC50 2.0/PLEDC or 5000 RSC50 2.0/PLED-ST (to be ordered separately), to light working area beneath

2,0 kg

5000 RSC50 2.0/MP

1 050001705



## 5000 RSC50/MPA140

corner shelf, 140 mm deep, for workshop equipment combination RSC50

- Dimensions: 630x630x35 mm, 140 mm deep
- Designed for application of aluminium profiles with LED strip item 5000 RSC50 2.0/PLEDC or 5000 RSC50 2.0/PLED-ST (to be ordered separately), to light working area beneath

3,8 kg

5000 RSC50/MPA140

1 050001706



## 5000 RSC50 2.0/CLL

linear guard for workshop equipment combination RSC50 2.0

- Dimensions: 740x125x30 mm
- To be applied to perforated tool panels
- Designed for application of aluminium profiles with LED strip item 5000 RSC50 2.0/PLEDC or 5000 RSC50 2.0/PLED-ST (to be ordered separately), to light working area beneath

1 kg

5000 RSC50 2.0/CLL

1 050001710



## 5000 RSC50/CAL

corner guard, for workshop equipment combination RSC50

- Dimensions: 655x655x30 mm
- Designed for application of aluminium profiles with LED strip item 5000 RSC50 2.0/PLEDC or 5000 RSC50 2.0/PLED-ST (to be ordered separately), to light working area beneath

1,2 kg

5000 RSC50/CAL

1 050001711



## 5000 RSC50 2.0/KFC

kit of 10 coloured drawer fronts, for workshop equipment combination RSC50 2.0

To customize colour of drawer fronts for workshop equipment combination RSC50 2.0.

Recommended for use in combination with worktops in anthracite grey RAL7016 (-A).

5000 RSC50 2.0/KFC2011



1 050001731

5000 RSC50 2.0/KFC3000



1 050001733

5000 RSC50 2.0/KFC5015



1 050001734

5000 RSC50 2.0/KFC7016



1 050001737





# WORKSHOP EQUIPMENT C45PRO 2.0

## WE ARE PROUD TO INTRODUCE THE 2.0 VERSION OF OUR SUCCESSFUL RANGE, C45PRO.

Based on the new **61.5-cm-long worktop**, this range stands out as even more convenient and professional, with a view to increasingly meeting the most demanding professionals' requirements.

The modular workshop equipment, **C45PRO 2.0**, allows you to create your own work environment according to both the amount of space you have available and your usage requirements.

This simple, flexible range based on predetermined combinations, can be expanded or changed in time. Alternatively, you can fully customize your workstation, starting with the worktops – available in stainless steel coated MDF or multi-ply wood – and supplementing them with the numerous parts and accessories you can choose from.

**Tailor your work environment to suit your needs.  
Make your workshop or garage look different.  
Choose from the preassembled solutions  
or create your workstation from scratch.**

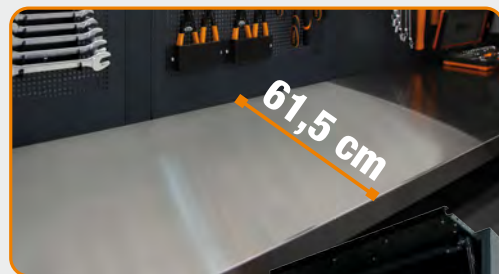

### Configure your workshop online



go to [www.beta-tools.com](http://www.beta-tools.com)

# Beta

## C45PRO 2.0

### C45PRO 2.0 DX

workshop equipment combination C45PRO 2.0

Combination comprising the following:

- 1 stainless steel coated MDF worktop, dimensions 2,040x615 mm (C45PRO 2.0 PXE/3-2.0MT)
- 1 stainless steel coated MDF worktop, dimensions 1,360x615 mm (C45PRO 2.0 PXE/2-1.3MT)
- 1 fixed module with 7 drawers (C45PRO 2.0 M7)
- 1 mobile roller cab with 7 drawers (C45PRO 2.0 C7)
- 1 fixed service module (C45PRO 2.0 MS)
- 1 fixed module with 5 drawers (C45PRO 2.0 M5)
- 1 fixed two-door module (C45PRO 2.0 MA)
- 1 self-supporting complete corner with stainless steel coated MDF worktop (C45PRO 2.0 CORNER/X)
- 5 perforated tool panels (C45PRO 2.0 PF)
- 5 wall-mounted cabinets (C45PRO 2.0 PM)
- 7 wall brackets, wide type (C45PRO 2.0 SL)
- 2 wall brackets, narrow type (C45PRO 2.0 SS)
- 2 single-door cabinets (C45PRO 2.0 AS1)

640 kg

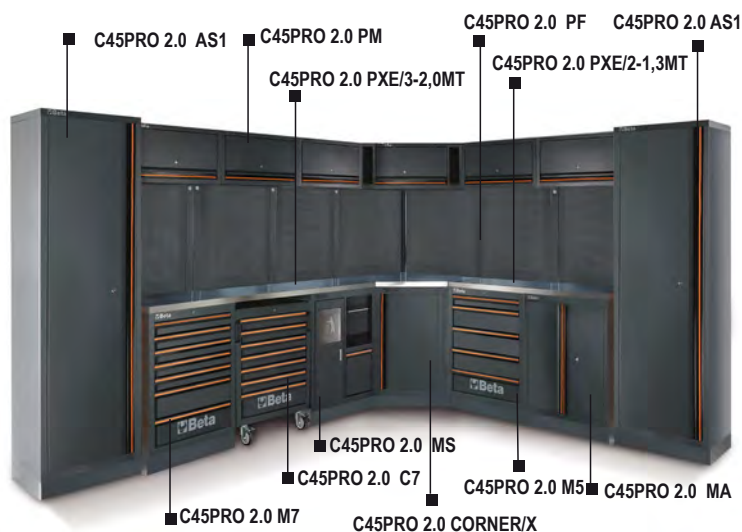

## C45PRO 2.0 DW

workshop equipment combination C45PRO 2.0

Combination comprising the following:

- 1 multi-ply wood worktop, dimensions 2,040x615 mm (C45PRO 2.0 PWE/3-2.0MT)
- 1 multi-ply wood worktop, dimensions 1,360x615 mm (C45PRO 2.0 PWE/2-1.3MT)
- 1 fixed module with 7 drawers (C45PRO 2.0 M7)
- 1 mobile roller cab with 7 drawers (C45PRO 2.0 C7)
- 1 fixed service module (C45PRO 2.0 MS)
- 1 fixed module with 5 drawers (C45PRO 2.0 M5)
- 1 fixed two-door module (C45PRO 2.0 MA)
- 1 self-supporting complete corner with multi-ply wood worktop (C45PRO 2.0 CORNER/W)
- 5 perforated tool panels (C45PRO 2.0 PF)
- 5 wall-mounted cabinets (C45PRO 2.0 PM)
- 7 wall brackets, wide type (C45PRO 2.0 SL)
- 2 wall brackets, narrow type (C45PRO 2.0 SS)
- 2 single-door cabinets (C45PRO 2.0 AS1)

606 kg

C45PRO 2.0 DW



1 045002032

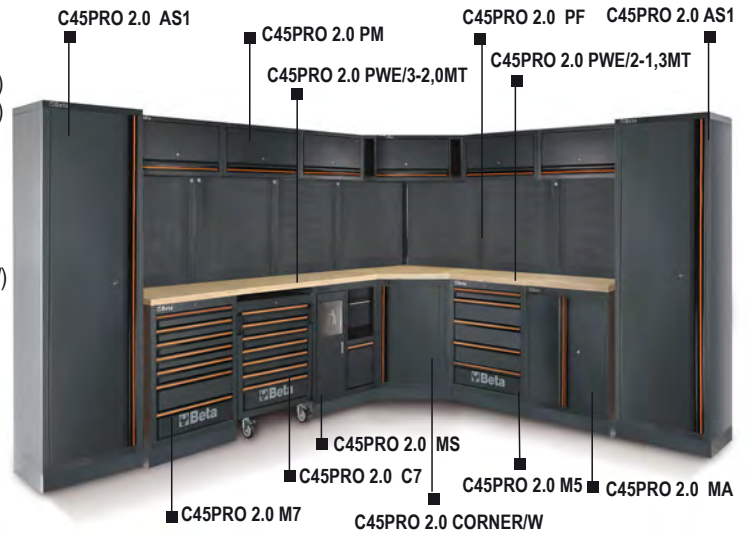

## C45PRO 2.0 FX

workshop equipment combination C45PRO 2.0

Combination comprising the following:

- 1 stainless steel coated MDF worktop, dimensions 2,040x615 mm (C45PRO 2.0 PXE/3-2.0MT)
- 1 stainless steel coated MDF worktop, dimensions 1,360x615 mm (C45PRO 2.0 PXE/2-1.3MT)
- 1 fixed two-door module (C45PRO 2.0 MA)
- 1 mobile roller cab with 7 drawers (C45PRO 2.0 C7)
- 1 fixed module with 7 drawers (C45PRO 2.0 M7)
- 1 fixed module with 2 built-in reels (C45PRO 2.0 ACT)
- 1 fixed service module (C45PRO 2.0 MS)
- 1 self-supporting complete corner with stainless steel coated MDF worktop (C45PRO 2.0 CORNER/X)
- 2 perforated tool panels (C45PRO 2.0 PF)
- 1 perforated tool panel, can be fitted with a power socket (not included) (C45PRO 2.0 PFE)
- 3 wall-mounted cabinets (C45PRO 2.0 PM)
- 1 tool wall system with aluminium shutter (C45PRO 2.0 PAS)
- 6 wall brackets, wide type (C45PRO 2.0 SL)
- 4 wall brackets, narrow type (C45PRO 2.0 SS)
- 2 single-door cabinets (C45PRO 2.0 AS1)

658 kg

C45PRO 2.0 FX



1 045002035

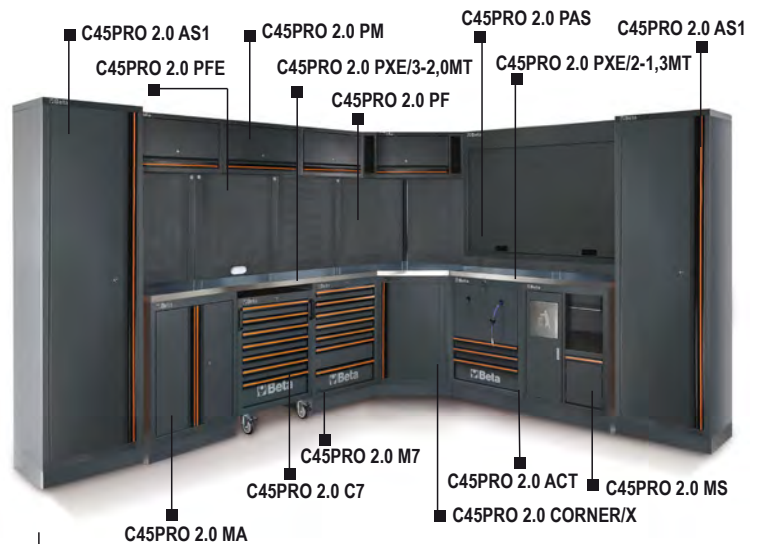

## C45PRO 2.0 FW

workshop equipment combination C45PRO 2.0

Combination comprising the following:

- 1 multi-ply wood worktop, dimensions 2,040x615 mm (C45PRO 2.0 PWE/3-2.0MT)
- 1 multi-ply wood worktop, dimensions 1,60x615 mm (C45PRO 2.0 PWE/2-1.3MT)
- 1 fixed two-door module (C45PRO 2.0 MA)
- 1 mobile roller cab with 7 drawers (C45PRO 2.0 C7)
- 1 fixed module with 7 drawers (C45PRO 2.0 M7)
- 1 fixed module with 2 built-in reels (C45PRO 2.0 ACT)
- 1 fixed service module (C45PRO 2.0 MS)
- 1 self-supporting complete corner with multi-ply wood worktop (C45PRO 2.0 CORNER/W)
- 2 perforated tool panels (C45PRO 2.0 PF)
- 1 perforated tool panel, can be fitted with a power socket (not included) (C45PRO 2.0 PFE)
- 3 wall-mounted cabinets (C45PRO 2.0 PM)
- 1 tool wall system with aluminium shutter (C45PRO 2.0 PAS)
- 6 wall brackets, wide type (C45PRO 2.0 SL)
- 4 wall brackets, narrow type (C45PRO 2.0 SS)
- 2 single-door cabinets (C45PRO 2.0 AS1)

625 kg

C45PRO 2.0 FW



1 045002045

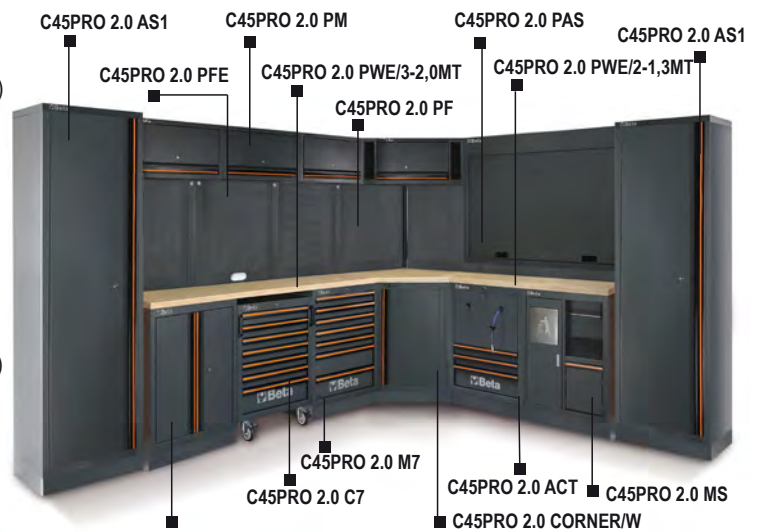

## C45PRO 2.0 GX

workshop equipment combination C45PRO 2.0

Combination comprising the following:

- 1 stainless steel coated MDF worktop, dimensions 2,040x615 mm (C45PRO 2.0 PXE/3-2.0MT)
- 1 stainless steel coated MDF worktop, dimensions 680x615 mm (C45PRO 2.0 PXE/1-0.7MT)
- 1 fixed module with 2 built-in reels (C45PRO 2.0 ACT)
- 1 mobile roller cab with 7 drawers (C45PRO 2.0 C7)
- 1 fixed module with 7 drawers (C45PRO 2.0 M7)
- 1 fixed two-door module (C45PRO 2.0 MA)
- 1 self-supporting complete corner with stainless steel coated MDF worktop (C45PRO 2.0 CORNER/X)
- 1 perforated tool panel (C45PRO 2.0 PF)
- 1 perforated tool panel, can be fitted with a power socket (not included) (C45PRO 2.0 PFE)
- 2 wall-mounted cabinets (C45PRO 2.0 PM)
- 1 tool wall system with aluminium shutter (C45PRO 2.0 PAS)
- 5 wall brackets, wide type (C45PRO 2.0 SL)
- 4 wall brackets, narrow type (C45PRO 2.0 SS)
- 2 single-door cabinets (C45PRO 2.0 AS1)

554 kg

C45PRO 2.0 GX

1 045002036

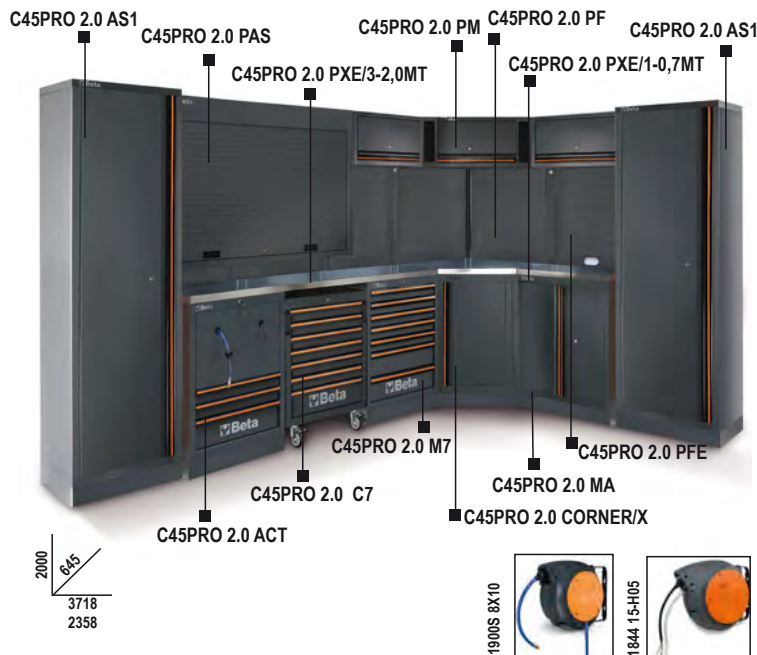

## C45PRO 2.0 GW

workshop equipment combination C45PRO 2.0

Combination comprising the following:

- 1 multi-ply wood worktop, dimensions 2,040x615 mm (C45PRO 2.0 PWE/3-2.0MT)
- 1 multi-ply wood worktop, dimensions 680x615 mm (C45PRO 2.0 PWE/1-0.7MT)
- 1 fixed module with 2 built-in reels (C45PRO 2.0 ACT)
- 1 mobile roller cab with 7 drawers (C45PRO 2.0 C7)
- 1 fixed module with 7 drawers (C45PRO 2.0 M7)
- 1 fixed two-door module (C45PRO 2.0 MA)
- 1 self-supporting complete corner with multi-ply wood worktop (C45PRO 2.0 CORNER/W)
- 1 perforated tool panel (C45PRO 2.0 PF)
- 1 perforated tool panel, can be fitted with a power socket (not included) (C45PRO 2.0 PFE)
- 2 wall-mounted cabinets (C45PRO 2.0 PM)
- 1 tool wall system with aluminium shutter (C45PRO 2.0 PAS)
- 6 wall brackets, wide type (C45PRO 2.0 SL)
- 2 wall brackets, narrow type (C45PRO 2.0 SS)
- 2 single-door cabinets (C45PRO 2.0 AS1)

551 kg

C45PRO 2.0 GW

1 045002037

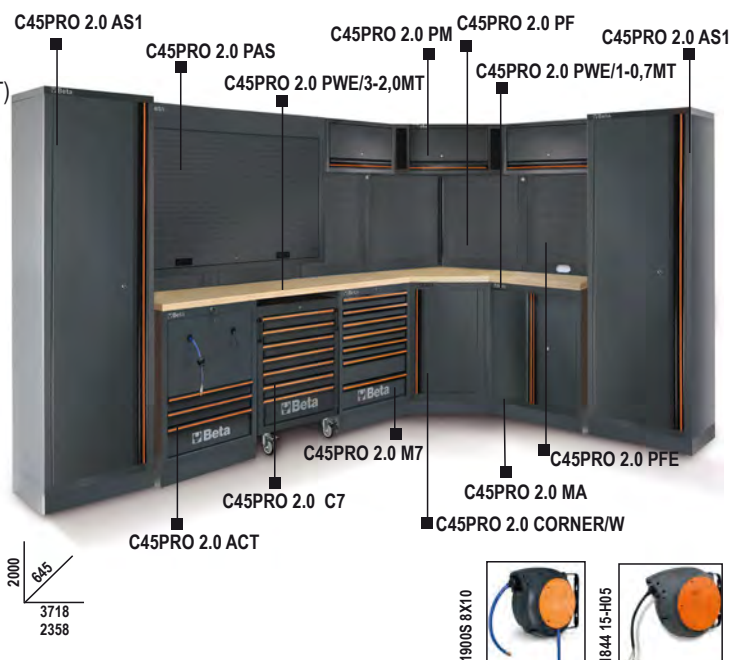

## C45PRO 2.0 X

workshop equipment combination C45PRO 2.0

Combination comprising the following:

- Stainless steel coated MDF worktop, dimensions 2,040x615 mm (C45PRO 2.0 PXE/3-2.0MT)
- Fixed module with 7 drawers (C45PRO 2.0 M7)
- Mobile roller cab with 7 drawers (C45PRO 2.0 C7)
- Fixed service module (C45PRO 2.0 MS)
- 3 perforated tool panels (C45PRO 2.0 PF)
- 3 wall-mounted cabinets (C45PRO 2.0 PM)
- 3 wall brackets, wide type (C45PRO 2.0 SL)
- 1 wall bracket, narrow type (C45PRO 2.0 SS)
- Two-door cabinet (C45PRO 2.0 AS2)

334 kg

C45PRO 2.0 X

1 045002001

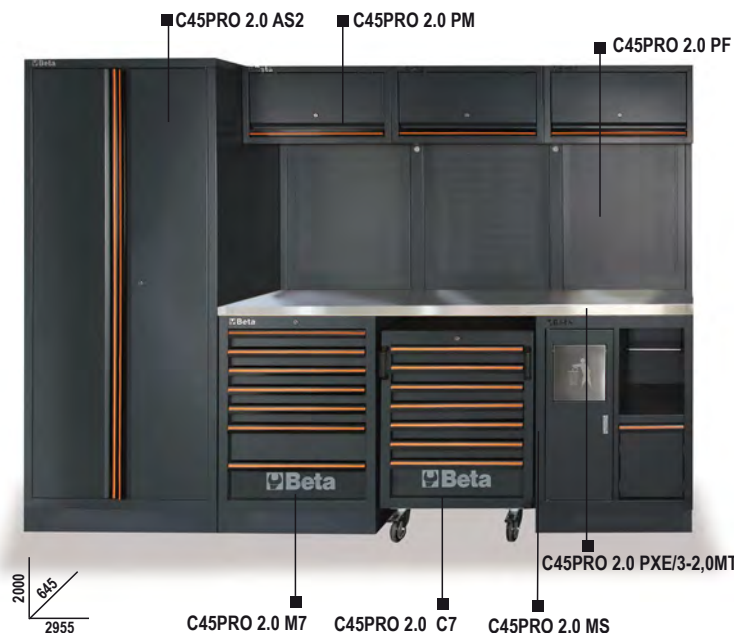

## C45PRO 2.0 W

workshop equipment combination C45PRO 2.0

Combination comprising the following:

- Multi-ply wood worktop, dimensions 2.040x615 mm (C45PRO 2.0 PWE/3-2,0MT)
- Fixed module with 7 drawers (C45PRO 2.0 M7)
- Mobile roller cab with 7 drawers (C45PRO 2.0 C7)
- Fixed service module (C45PRO 2.0 MS)
- 3 perforated tool panels (C45PRO 2.0 PF)
- 3 wall-mounted cabinets (C45PRO 2.0 PM)
- 3 wall brackets, wide type (C45PRO 2.0 SL)
- 1 wall bracket, narrow type (C45PRO 2.0 SS)
- Two-door cabinet (C45PRO 2.0 AS2)

318 kg

C45PRO 2.0 W

1 045002002

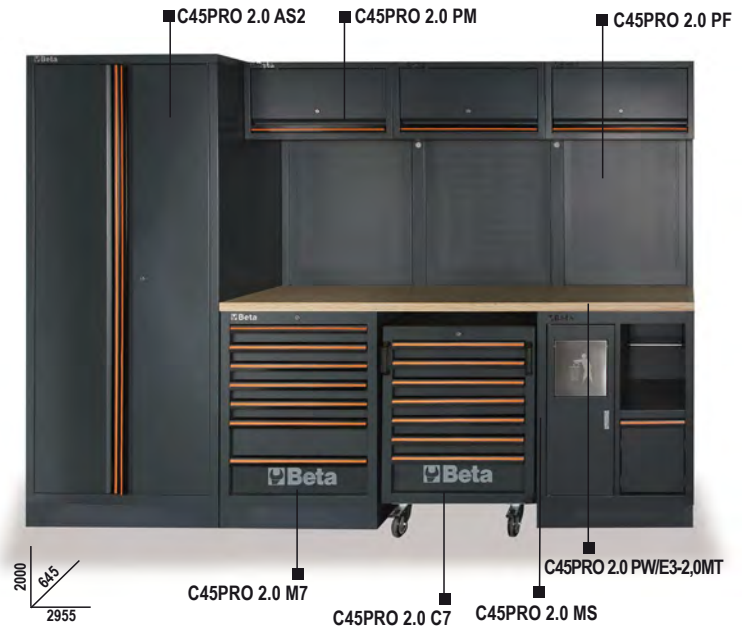

## C45PRO 2.0 HX

workshop equipment combination C45PRO 2.0

Combination comprising the following:

- 1 stainless steel coated MDF worktop, dimensions 2,040x615 mm (C45PRO 2.0 PXE/3-2,0MT)
- 1 fixed module with 2 built-in reels (C45PRO 2.0 ACT)
- 1 mobile roller cab with 7 drawers (C45PRO 2.0 C7)
- 1 fixed module with 4 drawers (C45PRO 2.0 M4)
- 3 wall-mounted cabinets (C45PRO 2.0 PM)
- 3 perforated tool panels (C45PRO 2.0 PF)
- 3 wall brackets, wide type (C45PRO 2.0 SL)
- 1 wall bracket, narrow type (C45PRO 2.0 SS)
- 1 two-door cabinet (C45PRO 2.0 AS2)

333 kg

C45PRO 2.0 HX

1 045002038

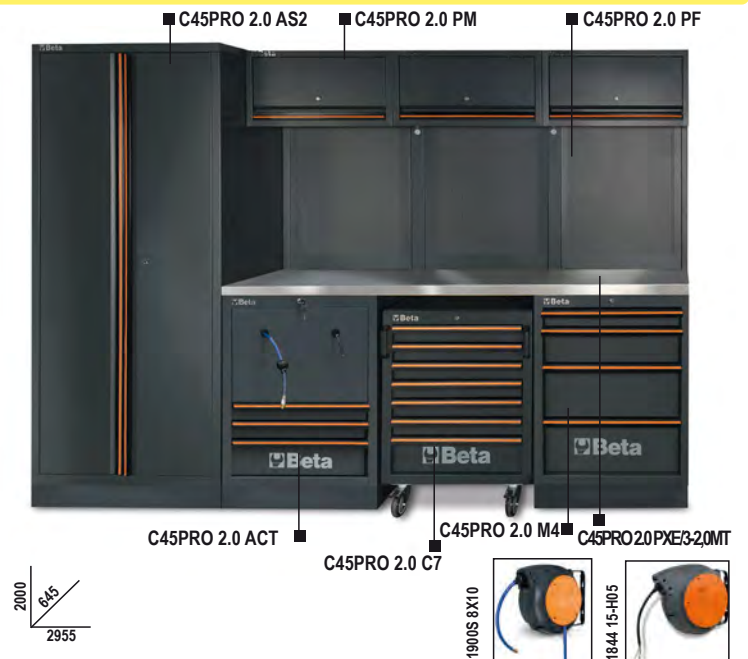

## C45PRO 2.0 HW

workshop equipment combination C45PRO 2.0

Combination comprising the following:

- 1 multi-ply wood worktop, dimensions 2,040x615 mm (C45PRO 2.0 PWE/3-2,0MT)
- 1 fixed module with 2 built-in reels (C45PRO 2.0 ACT)
- 1 mobile roller cab with 7 drawers (C45PRO 2.0 C7)
- 1 fixed module with 4 drawers (C45PRO 2.0 M4)
- 3 wall-mounted cabinets (C45PRO 2.0 PM)
- 3 perforated tool panels (C45PRO 2.0 PF)
- 3 wall brackets, wide type (C45PRO 2.0 SL)
- 1 wall bracket, narrow type (C45PRO 2.0 SS)
- 1 two-door cabinet (C45PRO 2.0 AS2)

318 kg

C45PRO 2.0 HW

1 045002039

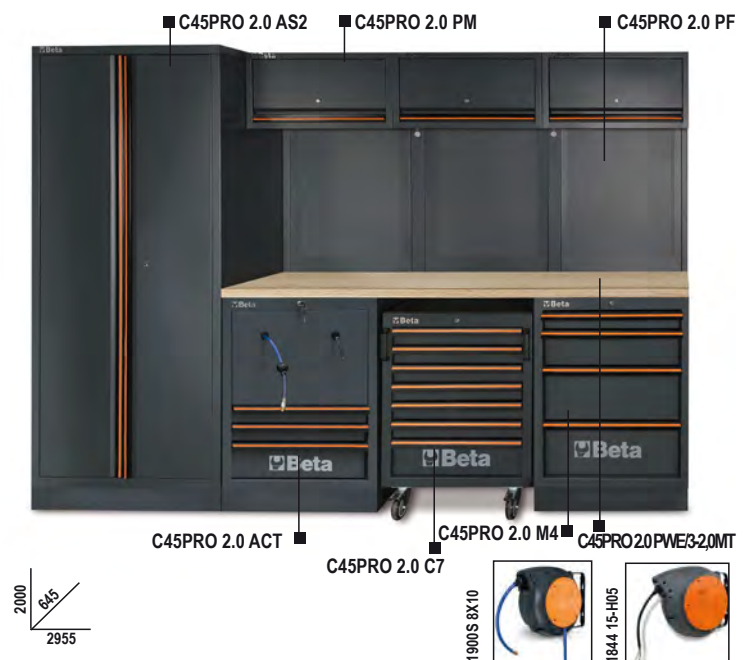

## C45PRO 2.0 AX

workshop equipment combination C45PRO 2.0

Combination comprising the following:

- Stainless steel coated MDF worktop, dimensions 2,040x615 mm (C45PRO 2.0 PXE/3-2.0MT)
- Fixed service module (C45PRO 2.0 MS)
- Fixed module with 7 drawers (C45PRO 2.0 M7)
- Fixed two-door module (C45PRO 2.0 MA)
- 3 wall-mounted cabinets (C45PRO 2.0 PM)
- 3 perforated tool panels (C45PRO 2.0 PF)
- 2 wall brackets, wide type (C45PRO 2.0 SL)
- 2 wall brackets, narrow type (C45PRO 2.0 SS)

234,5 kg

C45PRO 2.0 AX

1 045002003



## C45PRO 2.0 AW

workshop equipment combination C45PRO 2.0

Combination comprising the following:

- Multi-ply wood worktop, dimensions 2,040x615 mm (C45PRO 2.0 PWE/3-2.0MT)
- Fixed service module (C45PRO 2.0 MS)
- Fixed module with 7 drawers (C45PRO 2.0 M7)
- Fixed two-door module (C45PRO 2.0 MA)
- 3 wall-mounted cabinets (C45PRO 2.0 PM)
- 3 perforated tool panels (C45PRO 2.0 PF)
- 2 wall brackets, narrow type (C45PRO 2.0 SS)
- 2 wall brackets, wide type (C45PRO 2.0 SL)

219 kg

C45PRO 2.0 AW

1 045002004



## C45PRO 2.0 BX

workshop equipment combination C45PRO 2.0

Combination comprising the following:

- Stainless steel coated MDF worktop, dimensions 1,360x615 mm (C45PRO 2.0 PXE/2-1.3MT)
- Fixed module with 5 drawers (C45PRO 2.0 M5)
- Fixed two-door module (C45PRO 2.0 MA)
- 2 wall-mounted cabinets (C45PRO 2.0 PM)
- 2 perforated tool panels (C45PRO 2.0 PF)
- 2 wall brackets, wide type (C45PRO 2.0 SL)
- 1 wall bracket, narrow type (C45PRO 2.0 SS)
- Single-door cabinet (C45PRO 2.0 AS1)

206 kg

C45PRO 2.0 BX

1 045002021



## C45PRO 2.0 BW

workshop equipment combination C45PRO 2.0

Combination comprising the following:

- Multi-ply wood worktop, dimensions 1,360x615 mm (C45PRO 2.0 PWE/2-1.3MT)
- Fixed module with 5 drawers (C45PRO 2.0 M5)
- Fixed two-door module (C45PRO 2.0 MA)
- 2 wall-mounted cabinets (C45PRO 2.0 PM)
- 2 perforated tool panels (C45PRO 2.0 PF)
- 2 wall brackets, wide type (C45PRO 2.0 SL)
- 1 wall bracket, narrow type (C45PRO 2.0 SS)
- Single-door cabinet (C45PRO 2.0 AS1)

196 kg

C45PRO 2.0 BW

1 045002022



## C45PRO 2.0 EX

workshop equipment combination C45PRO 2.0

Combination comprising the following:

- 2 perforated tool panels (C45PRO 2.0 PF)
- 2 wall-mounted cabinets (C45PRO 2.0 PM)
- 2 wall brackets, wide type (C45PRO 2.0 SL)
- 1 wall bracket, narrow type (C45PRO 2.0 SS)
- 1 single-door cabinet (C45PRO 2.0 AS1)

• Fixed module with 7 drawers and stainless steel coated MDF worktop, dimensions 1,360x615 mm (C45PRO 2.0 M7A/X):

- 1 drawer 1,248x406 mm
- 6 drawers 782x406 mm
- 5 drawers 65 mm high
- 1 drawer 145 mm high
- 1 storage compartment with intermediate shelf and door

203 kg

C45PRO 2.0 EX

1 045002033



## C45PRO 2.0 EW

workshop equipment combination C45PRO 2.0

Combination comprising the following:

- 2 perforated tool panels (C45PRO 2.0 PF)
- 2 wall-mounted cabinets (C45PRO 2.0 PM)
- 2 wall brackets, wide type (C45PRO 2.0 SL)
- 1 wall bracket, narrow type (C45PRO 2.0 SS)
- 1 single-door cabinet (C45PRO 2.0 AS1)

• Fixed module with 7 drawers

and multiply wood worktop, dimensions 1,360x615 mm (C45PRO 2.0 M7A/W):

- 1 drawer 1,248x406 mm
- 6 drawers 782x406 mm
- 5 drawers 65 mm high
- 1 drawer 145 mm high
- 1 storage compartment with intermediate shelf and door

193 kg

C45PRO 2.0 EW

1 045002034

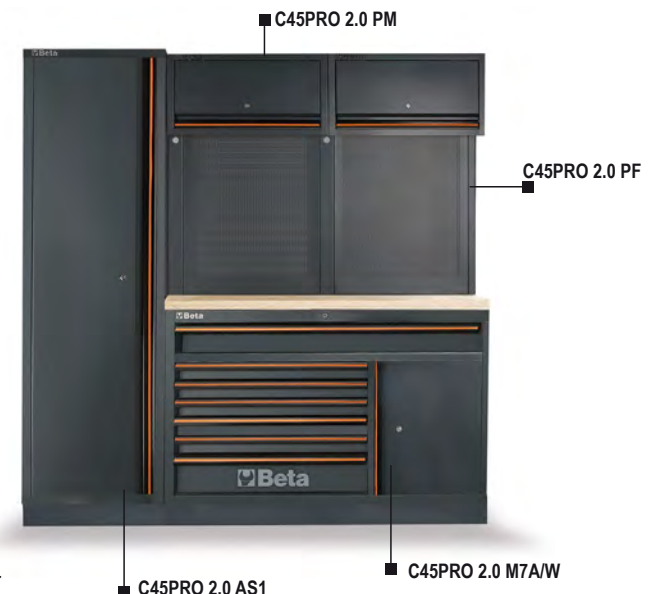

## C45PRO 2.0 CX

workshop equipment combination C45PRO 2.0

Combination comprising the following:

- Stainless steel coated MDF worktop, dimensions 1,360x615 mm (C45PRO 2.0 PXE/2-1.3MT)
- Fixed service module (C45PRO 2.0 MS)
- Fixed module with 7 drawers (C45PRO 2.0 M7)
- 2 wall-mounted cabinets (C45PRO 2.0 PM)
- 2 perforated tool panels (C45PRO 2.0 PF)
- 2 wall brackets, wide type (C45PRO 2.0 SL)
- 1 wall bracket, narrow type (C45PRO 2.0 SS)
- Single-door cabinet (C45PRO 2.0 AS1)

225 kg

C45PRO 2.0 CX

1 045002023



## C45PRO 2.0 CW

workshop equipment combination C45PRO 2.0

Combination comprising the following:

- Multi-ply wood worktop, dimensions 1,360x615 mm (C45PRO 2.0 PWE/2-1.3MT)
- Fixed service module (C45PRO 2.0 MS)
- Fixed module with 7 drawers (C45PRO 2.0 M7)
- 2 wall-mounted cabinets (C45PRO 2.0 PM)
- 2 perforated tool panels (C45PRO 2.0 PF)
- 2 wall brackets, wide type (C45PRO 2.0 SL)
- 1 wall bracket, narrow type (C45PRO 2.0 SS)
- Single-door cabinet (C45PRO 2.0 AS1)

215 kg

C45PRO 2.0 CW

1 045002024

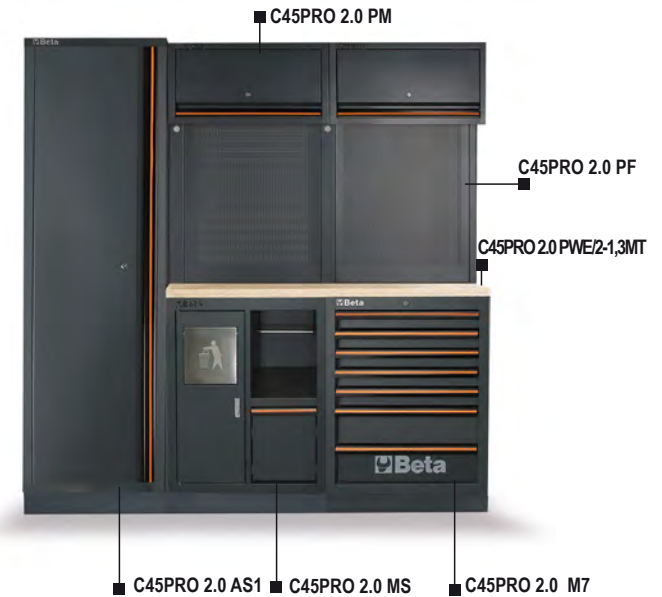

## C45PRO 2.0 BPX-2,0

workshop equipment combination C45PRO 2.0

Combination comprising the following:

- Stainless steel coated MDF worktop, dimensions 2,040x615 mm (C45PRO 2.0 PXE/3-2.0MT)
- Fixed module with 7 drawers (C45PRO 2.0 M7)
- Fixed module with 5 drawers (C45PRO 2.0 M5)
- 3 perforated tool panels (C45PRO 2.0 PF)
- 2 wall brackets, wide type (C45PRO 2.0 SL)
- 2 wall brackets, narrow type (C45PRO 2.0 SS)

181 kg

C45PRO 2.0 BPX-2,0

1 045002042



## C45PRO 2.0 BPW-2,0

workbenches for workshop equipment combination C45PRO 2.0

Combination comprising the following:

- Multi-ply wood worktop, dimensions 2,040x615 mm (C45PRO 2.0 PWE/3-2.0MT)
- Fixed module with 7 drawers (C45PRO 2.0 M7)
- Fixed module with 5 drawers (C45PRO 2.0 M5)
- 3 perforated tool panels (C45PRO 2.0 PF)
- 2 wall brackets, wide type (C45PRO 2.0 SL)
- 2 wall brackets, narrow type (C45PRO 2.0 SS)

165 kg

C45PRO 2.0 BPW-2,0

1 045002052

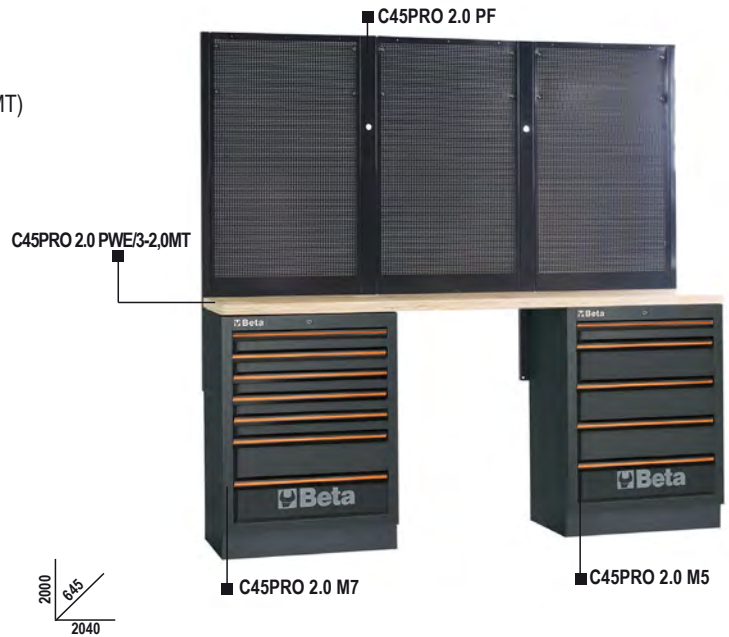

## C45PRO 2.0 BPX-1,3

workshop equipment combination C45PRO 2.0

Combination comprising the following:

- Stainless steel coated MDF worktop, dimensions 1,360x615 mm (C45PRO 2.0 PXE/2-1.3MT)
- Fixed module with 7 drawers (C45PRO 2.0 M7)
- Fixed module with 5 drawers (C45PRO 2.0 M5)
- 2 perforated tool panels (C45PRO 2.0 PF)
- 1 wall bracket, wide type (C45PRO 2.0 SL)
- 2 wall brackets, narrow type (C45PRO 2.0 SS)

155 kg

C45PRO 2.0 BPX-1,3

1 045002041

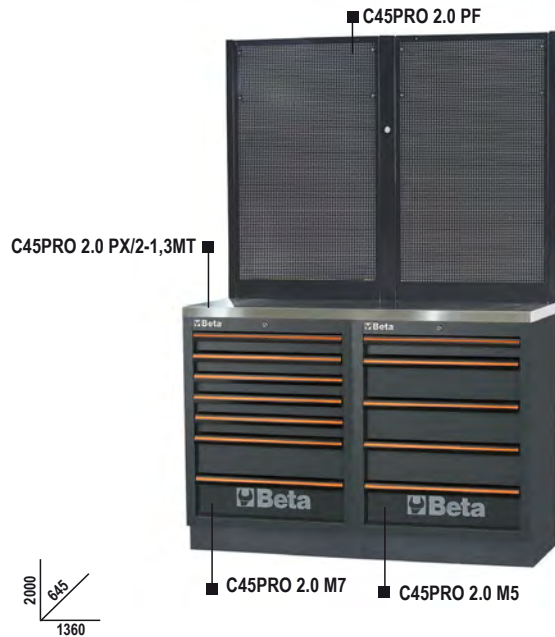

## C45PRO 2.0 BPW-1,3

workshop equipment combination C45PRO 2.0

Combination comprising the following:

- Multi-ply wood worktop, dimensions 1,360x615 mm (C45PRO 2.0 PWE/2-1.3MT)
- Fixed module with 7 drawers (C45PRO 2.0 M7)
- Fixed module with 5 drawers (C45PRO 2.0 M5)
- 2 perforated tool panels (C45PRO 2.0 PF)
- 1 wall bracket, wide type (C45PRO 2.0 SL)
- 2 wall brackets, narrow type (C45PRO 2.0 SS)

145 kg

C45PRO 2.0 BPW-1,3

1 045002051



## C45PRO 2.0 BLX

workbench for workshop equipment combination C45PRO 2.0

- Worktop (1,360x615 mm) made from stainless steel coated MDF
- Sheet metal framework
- With vertically adjustable feet
- Can accommodate a vice (1599P/150, to be ordered separately)
- To be used only as an addition to a workshop equipment combination, not as a stand-alone element



C45PRO 2.0 BLX



1

045002156

## C45PRO 2.0 BLW

workbench for workshop equipment combination C45PRO 2.0

- Worktop (1,360x615 mm) made from multi-ply wood
- Sheet metal framework
- With vertically adjustable feet
- Can accommodate a vice (1599P/150, to be ordered separately)
- To be used only as an addition to a workshop equipment combination, not as a stand-alone element



C45PRO 2.0 BLW



1

045002157

## C45PRO 2.0 M7A/X

fixed module with 7 drawers, for workshop equipment combination C45PRO 2.0

- Worktop (1,360x615 mm) made from stainless steel coated MDF
- 1 drawer (1,248x406 mm) with ball bearing slides
- 6 drawers (782x406 mm) with ball bearing slides:
  - 5 drawers 65 mm high
  - 1 drawer 145 mm high
- Drawer bases protected by foamed rubber mats
- Front centralized lock
- With vertically adjustable feet
- Can be fitted with thermoformed trays
- 1 storage compartment with intermediate shelf and door, interior dimensions 504x424x597 mm
- Can accommodate a vice (1599P/150, to be ordered separately)



81 kg

h	max
65 mm	25 kg
105 mm	40 kg
145 mm	30 kg

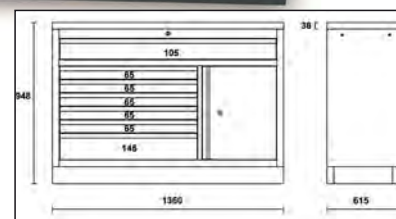

C45PRO 2.0 M7A/X



1

045002161

## C45PRO 2.0 M7A/W

fixed module with 7 drawers, for workshop equipment combination  
C45PRO 2.0

- Multi-ply wood worktop, 1,360x615 mm
- 1 drawer (1,248x406 mm) with ball bearing slides
- 6 drawers (782x406 mm) with ball bearing slides:
  - 5 drawers 65 mm high
  - 1 drawer 145 mm high
- Drawer bases protected by foamed rubber mats
- Front centralized lock
- With vertically adjustable feet
- Can be fitted with thermoformed trays
- 1 storage compartment with intermediate shelf and door, interior dimensions, 504x424x597 mm
- Can accommodate a vice (1599P/150, to be ordered separately)

80 kg

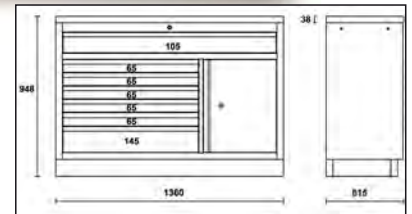

h	max
65 mm	25 kg
105 mm	40 kg
145 mm	30 kg

C45PRO 2.0 M7A/W

1 045002171

## C45PRO 2.0 MWS/X

Work Station roller cab with 7 drawers and built-in waste bin

- worktop (1680 mm) made of stainless steel coated MDF
- 1 drawer (1248x406 mm) with ball bearing slides
- 6 drawers (782x406 mm) with ball bearing slides:
  - 5 drawers 65 mm high
  - 1 drawer 145 mm high
- drawer bases protected by foamed rubber mats
- can be fitted with thermoformed trays
- storage compartment with intermediate shelf and door, interior dimensions 504x424x597 mm
- built-in waste bin
- built-in paper roll compartment
- 4 heavy-duty castors, Ø 150 mm, 2 fixed and 2 steering with brakes
- front centralised lock
- can accommodate a vice (1599P/150, to be ordered separately)

126 kg

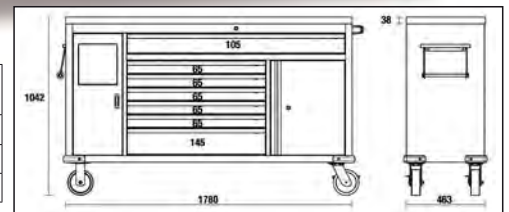

h	max
65 mm	25 kg
105 mm	40 kg
145 mm	30 kg

C45PRO 2.0 MWS/X

1 045000181

## C45PRO 2.0 MWS/W

Work Station roller cab with 7 drawers and built-in waste bin

- multi-ply wood worktop (1680 mm)
- 1 drawer (1248x406 mm) with ball bearing slides
- 6 drawers (782x406 mm) with ball bearing slides:
  - 5 drawers 65 mm high
  - 1 drawer 145 mm high
- drawer bases protected by foamed rubber mats
- can be fitted with thermoformed trays
- storage compartment with intermediate shelf and door, interior dimensions 504x424x597 mm
- built-in waste bin
- built-in paper roll compartment
- 4 heavy-duty castors, Ø 150 mm, 2 fixed and 2 steering with brakes
- front centralised lock
- can accommodate a vice (1599P/150, to be ordered separately)

122 kg

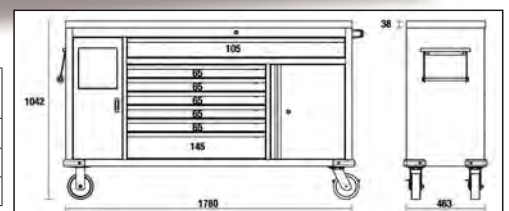

h	max
65 mm	25 kg
105 mm	40 kg
145 mm	30 kg

C45PRO 2.0 MWS/W

1 045000191

## C45PRO 2.0 CPF

pair of perforated tool panels for mobile roller cab C45PRO MWS

Supplied complete with framework  
50-hook GPS kit included

11 kg



C45PRO 2.0 CPF



1 045000195



## C45PRO 2.0 PXE/1-0,7MT

worktop made from stainless steel coated MDF, 680x615 mm, for workbench, for workshop equipment combination C45PRO 2.0

- thickness: 38 mm
- can accommodate a vice (1599P/150, to be ordered separately)
- complete with 2 spacers and 2 exterior side pads



14 kg

C45PRO 2.0 PXE/1-0,7MT



1 045002131

## C45PRO 2.0 PWE/1-0,7MT

worktop made from multi-ply wood, 680x615 mm, for workbench, for workshop equipment combination C45PRO 2.0

- thickness: 38 mm
- can accommodate a vice (1599P/150, to be ordered separately)
- complete with 2 spacers and 2 exterior side pads



8 kg

C45PRO 2.0 PWE/1-0,7MT



1 045002141

## C45PRO 2.0 PXE/2-1,3MT

worktop made from stainless steel coated MDF, 1360x615 mm, for workbench, for workshop equipment combination C45PRO 2.0

- thickness: 38 mm
- can accommodate a vice (1599P/150, to be ordered separately)
- complete with 4 spacers and 2 exterior side pads



27 kg

C45PRO 2.0 PXE/2-1,3MT



1 045002133

## C45PRO 2.0 PWE/2-1,3MT

worktop made from multi-ply wood, 1360x615 mm, for workbench, for workshop equipment combination C45PRO 2.0

- thickness: 38 mm
- can accommodate a vice (1599P/150, to be ordered separately)
- complete with 4 spacers and 2 exterior side pads



17 kg

C45PRO 2.0 PWE/2-1,3MT



1 045002143

## C45PRO 2.0 PXE/3-2,0MT

worktop made from stainless steel coated MDF, 2040x615 mm, for workbench, for workshop equipment combination C45PRO 2.0

- thickness: 38 mm
- can accommodate a vice (1599P/150, to be ordered separately)
- complete with 6 spacers and 2 exterior side pads

41,5 kg



C45PRO 2.0 PXE/3-2,0MT

1 045002140

## C45PRO 2.0 PWE/3-2,0MT

worktop made from multi-ply wood, 2040x615 mm, for workbench, for workshop equipment combination C45PRO 2.0

- thickness: 38 mm
- can accommodate a vice (1599P/150, to be ordered separately)
- complete with 6 spacers and 2 exterior side pads

26 kg



C45PRO 2.0 PWE/3-2,0MT

1 045002150

## C45PRO 2.0 C5

mobile roller cab with 5 drawers, for workshop equipment combination C45PRO 2.0

- ABS worktop with anti-fall edges
- 5 drawers (532x406 mm) with ball bearing slides
- 4 swivel castors, Ø 100 mm (2 with brakes)
- Drawer bases protected by foamed rubber mats
- Front centralized lock
- Can be fitted with thermoformed trays
- Handles built into frame for improved ease of handling

46 kg

h	max
65 mm	25 kg
145 mm	30 kg

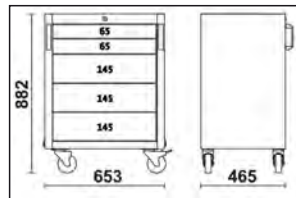
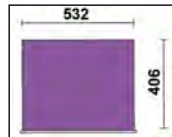

C45PRO 2.0 C5

1 045000226

 **Beta**

## C45PRO 2.0 C7

mobile roller cab with 7 drawers, for workshop equipment combination  
C45PRO 2.0

- ABS worktop with anti-fall edges
- 7 drawers (532x406 mm) with ball bearing slides
- 4 swivel castors, Ø 100 mm (2 with brakes)
- Drawer bases protected by foamed rubber mats
- Front centralized lock
- Can be fitted with thermoformed trays
- Handles built into frame for improved ease of handling

50 kg

h	max
65 mm	25 kg
145 mm	30 kg

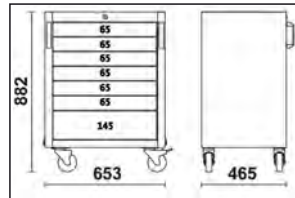
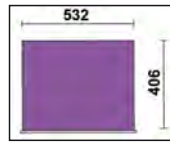

C45PRO 2.0 C7

1 045000228

## C45PRO 2.0 M4

fixed module with 4 drawers, for workshop equipment combination  
C45PRO 2.0

- 4 drawers (566x406 mm) with ball bearing slides
- Drawer bases protected by foamed rubber mats
- Front centralized lock
- With vertically adjustable feet
- Can be fitted with thermoformed trays

46,7 kg

h	max
65 mm	25 kg
145 mm	30 kg
225 mm	30 kg

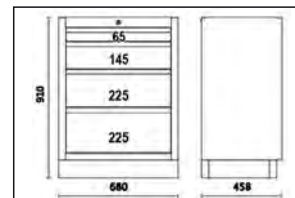
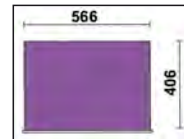

C45PRO 2.0 M4

1 045000234

## C45PRO 2.0 M5

fixed module with 5 drawers, for workshop equipment combination  
C45PRO 2.0

- 5 drawers (566x406 mm) with ball bearing slides
- Drawer bases protected by foamed rubber mats
- Front centralized lock
- With vertically adjustable feet
- Can be fitted with thermoformed trays

49,3 kg

h	max
65 mm	25 kg
145 mm	30 kg

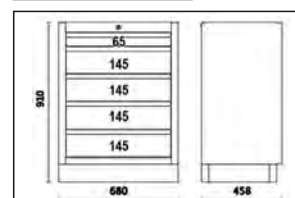

C45PRO 2.0 M5

1 045000235

## C45PRO 2.0 M7

fixed module with 7 drawers, for workshop equipment combination  
C45PRO 2.0

- 7 drawers (566x406 mm) with ball bearing slides
- Drawer bases protected by foamed rubber mats
- Front centralized lock
- With vertically adjustable feet
- Can be fitted with thermoformed trays

54,3 kg

h	max
65 mm	25 kg
145 mm	30 kg

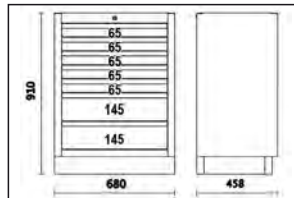
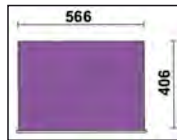

C45PRO 2.0 M7



## C45PRO 2.0 M8

fixed module with 8 drawers, for workshop equipment combination  
C45PRO 2.0

- 8 drawers (566x406 mm) with ball bearing slides
- Drawer bases protected by foamed rubber mats
- Front centralized lock
- With vertically adjustable feet
- Can be fitted with thermoformed trays

56,8 kg

h	max
65 mm	25 kg
145 mm	30 kg

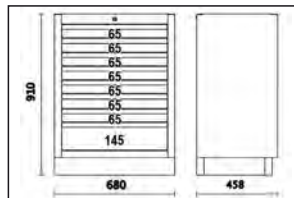
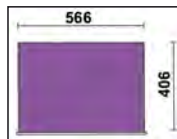

C45PRO 2.0 M8



## C45PRO 2.0 MS

fixed service module, for workshop equipment combination C45PRO  
2.0

- Built-in waste bin
- Paper roll compartment
- With vertically adjustable feet

37 kg

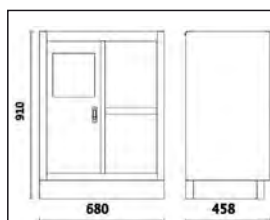

C45PRO 2.0 MS



## C45PRO 2.0 RD/X

fixed sorted waste collection module, for workshop equipment combination C45PRO 2.0

- Stainless steel coated MDF worktop (1360x615 mm)
- Sturdy sheet metal frame complete with 4 containers with up-and-over door for sorting waste
- Each container is fitted with:
  - one removable plastic bin; capacity: 25 l
  - 4 swivel castors, Ø 60 mm
- Supplied with kit of 4 coloured adhesive tapes
- With vertically adjustable feet

80 kg



C45PRO 2.0 RD/X

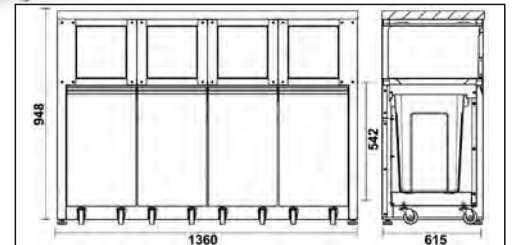

C45PRO 2.0 RD/X

1 045002241

## C45PRO 2.0 RD/W

fixed sorted waste collection module for workshop equipment combination C45PRO 2.0

- Multi-ply wood worktop (1,360x615 mm)
- Sturdy sheet metal frame complete with 4 containers with up-and-over door for sorting waste
- Each container is fitted with:
  - one removable plastic bin; capacity: 25 l
  - 4 swivel castors, Ø 60 mm
- Supplied with kit of 4 coloured adhesive tapes
- With vertically adjustable feet

80 kg



C45PRO 2.0 RD/W

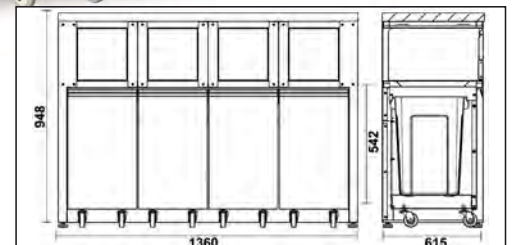

C45PRO 2.0 RD/W

1 045002240

## C45PRO 2.0 MA

fixed two-door module, for workshop equipment combination C45PRO 2.0

- With lock
- Vertically adjustable interior shelf
- Interior dimensions: 670x420 mm
- With vertically adjustable feet

29,4 kg

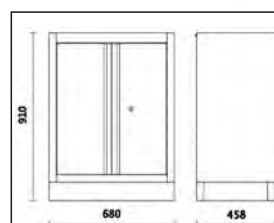

C45PRO 2.0 MA

1 045000232

## C45PRO 2.0 MAL

fixed module, 1360 mm long, with 2 sheet metal doors, for workshop equipment combination C45PRO 2.0

- With lock
- Vertically adjustable interior shelf
- Interior dimensions: 1,355x420 mm
- With vertically adjustable feet

44,8 kg

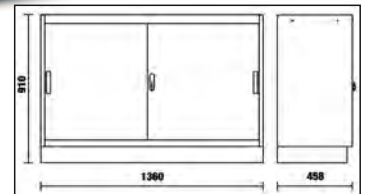

C45PRO 2.0 MAL

1 045000229

## C45PRO 2.0 MAT

fixed module, 1360 mm long, with 2 clear polycarbonate doors, for workshop equipment combination C45PRO 2.0

- With lock
- Vertically adjustable interior shelf
- Interior dimensions: 1,355x420 mm
- With vertically adjustable feet

44,1 kg

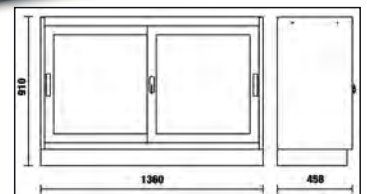

C45PRO 2.0 MAT

1 045000230

## C45PRO 2.0 M3A

fixed module with 3 drawers and 2 doors, for workshop equipment combination C45PRO 2.0

- 3 drawers (566x406 mm) with ball bearing slides
- Drawer bases protected by foamed rubber mats
- Can be fitted with thermoformed trays
- Front centralized lock
- Storage compartment with double door and lock (interior dimensions 670x440 mm), complete with intermediate shelf
- With vertically adjustable feet

44 kg

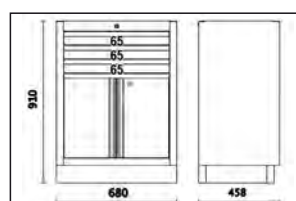
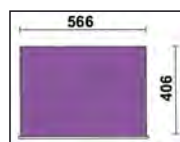

C45PRO 2.0 M3A

1 045000231

## C45PRO 2.0 MRE

fixed module for charging power tools,  
for workshop equipment combination C45PRO 2.0

- Pull-out side compartment with ball bearing slides, for storing power tools
- Fixed side compartment with door and lock for storing chargers and batteries, equipped with:  
vertically adjustable shelf;  
rubber-protected cable bushings;  
ventilation slots;
- 1 drawer (256x400x190 mm), with ball bearing slides
- Front centralized lock
- Vertically adjustable feet

57 kg

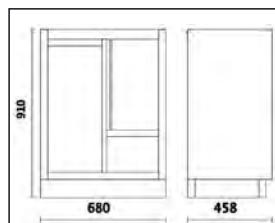

C45PRO 2.0 MRE

1 045000242

## C45PRO 2.0 ML

fixed module with built-in sink, for workshop equipment combination  
C45PRO 2.0

Technical specifications:

- Stainless steel basin
- Supplied complete with:  
1 mixer tap  
1 drain unit  
1 sink stopper  
1 filter cap  
1 soap dispenser

Fixed two-door module with lock:

- Usable interior dimensions: 600x603x416 mm
- With vertically adjustable feet

44 kg

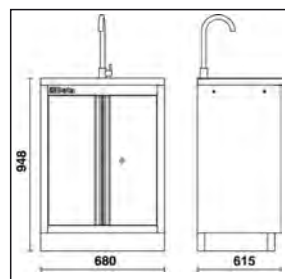

C45PRO 2.0 ML

1 045002233

## C45PRO 2.0 ACT

fixed module with 3 drawers and 2 built-in reels,  
for workshop equipment combination C45PRO 2.0

- 3 drawers (566x406 mm) with ball bearing slides
- Drawer bases protected by foamed rubber mats
- Front centralized lock
- With vertically adjustable feet

Supplied complete with:

- 1 built-in compressed air or cold water hose reel, 8 mm, length 10 m item 1900S 8x10
- 1 built-in cable reel, length 15 m, item 1844 15-H05

50,7 kg



h	max
65 mm	25 kg
145 mm	30 kg

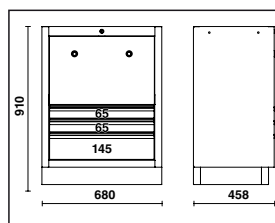
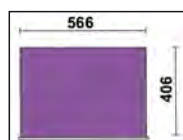

C45PRO 2.0 ACT

1 045000247

## C45PRO 2.0 TC

fixed reel module with 3 drawers, for workshop equipment combination C45PRO 2.0, empty

- 3 drawers (566x406 mm) with ball bearing slides
  - Drawer bases protected by foamed rubber mats
  - Front centralized lock
  - With vertically adjustable feet
- Can accommodate 2 reels, to be chosen from the following:
    - 2 compressed air or cold water hose reels, 8 mm, length 10 m item 1900S 8x10
    - 2 cable reels, to be chosen from the following items: 1843 15-H05, 1844 10-H05, 1844 15-H05, 1844 15-H07, 1845 12-H05, 1846 10-H05, 1846 10-H07 and 1846 15-H05
    - 1 compressed air or cold water hose reel, 8 mm, length 10 m item 1900S 8x10 and 1 cable reel, to be chosen from the above-mentioned items

h		
	65 mm	25 kg
	145 mm	30 kg

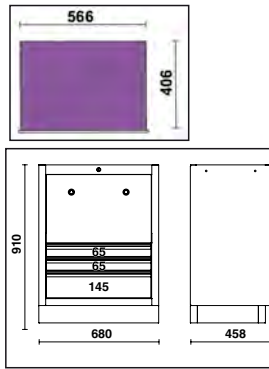

📦 40,9 kg

C45PRO 2.0 TC



1

045000249

## C45PRO 2.0 T3

3-tier tool trolley, for workshop equipment combination C45PRO 2.0

- 4 swivel castors, Ø 100 mm (one with brake)
- Static load capacity: 200 kg (distributed over 3 shelves)

📦 19,2 kg

C45PRO 2.0 T3



1

045000250

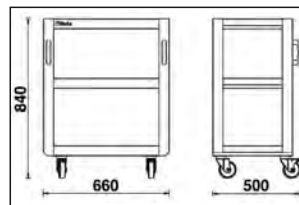

## C45PRO 2.0 SS

side wall brackets, narrow type, for workshop equipment combination C45PRO 2.0

- Dimensions: 1420x32.5x30 mm

📦 1,5 kg

C45PRO 2.0 SS



1

045000333



## C45PRO 2.0 SL

side wall brackets, wide type, for workshop equipment combination C45PRO 2.0

- Dimensions: 1420x65x30 mm

📦 2 kg

C45PRO 2.0 SL



1

045000366



## C45PRO 2.0 PAS

tool wall system, for workshop equipment combination C45PRO 2.0

- Aluminium shutter, vertically adjustable, with lock
- Two removable perforated tool panels
- Can be used in combination with 1.3-m-long workbench
- 50-hook GPS kit included

49,7 kg

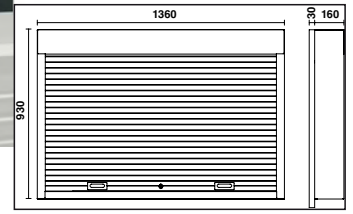

C45PRO 2.0 PAS

1 045000290

## C45PRO 2.0 PF

perforated tool panel, for workshop equipment combination C45PRO 2.0

- Dimensions: 1052x614.5x24 mm

5,3 kg



C45PRO 2.0 PF

1 045000313

## C45PRO 2.0 PFE

perforated tool panel, for workshop equipment combination C45PRO 2.0

- Dimensions: 1052x614.5x24 mm
- Can be fitted with 1 power socket (not included)

5,3 kg



C45PRO 2.0 PFE

1 045000312

## C45PRO 2.0 MP

sheet metal shelf for perforated tool panels, for workshop equipment combination C45PRO 2.0

Dimensions: 614x160x80 mm

2,1 kg



C45PRO 2.0 MP

1 045000315

## C45PRO 2.0 CORNER/X

self-supporting complete corner, for workshop equipment combination  
C45PRO 2.0

- Suspended corner cabinet with lock and 2 storage compartments
- 2 perforated tool panels (1,052x800 mm)
- Stainless steel coated MDF corner worktop (1,018x1,018 mm)
- Lower corner module with large storage compartment
- With vertically adjustable feet

127 kg

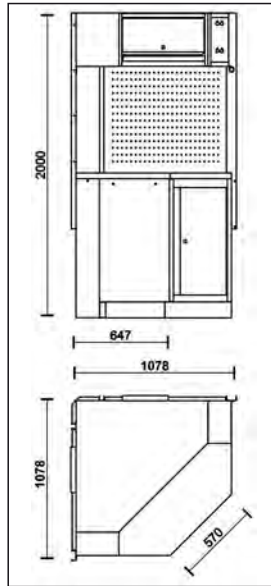

C45PRO 2.0 CORNER/X

1 045002401

## C45PRO 2.0 CORNER/W

self-supporting complete corner, for workshop equipment combination  
C45PRO 2.0

- Suspended corner cabinet with lock and 2 storage compartments
- 2 perforated tool panels (1,052x800 mm)
- Multi-ply wood corner worktop (1,018x1,018 mm)
- Lower corner module with large storage compartment
- With vertically adjustable feet

119 kg

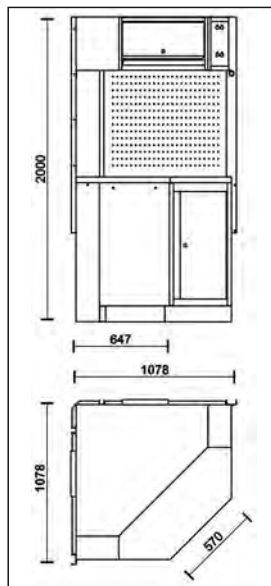

C45PRO 2.0 CORNER/W

1 045002411

Beta

## C45PRO 2.0 CAI/X

lower corner module, for workshop equipment combination C45PRO 2.0

- Stainless steel coated MDF corner worktop (1,018x1,018 mm)
- Fixed corner module with large storage compartment
- With vertically adjustable feet

77 kg

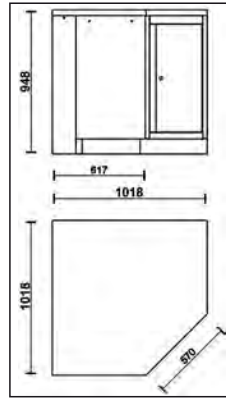

C45PRO 2.0 CAI/X

1 045002412

## C45PRO 2.0 CAI/W

lower corner module, for workshop equipment combination C45PRO 2.0

- Multi-ply wood corner worktop (1,018x1,018 mm)
- Fixed corner module with large storage compartment
- With vertically adjustable feet

69 kg

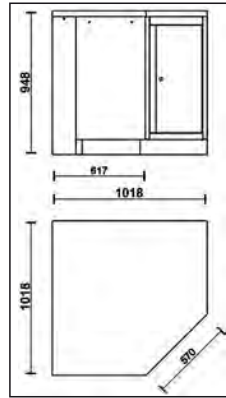

C45PRO 2.0 CAI/W

1 045002402

## C45PRO 2.0 PM

wall-mounted cabinet, for workshop equipment combination C45PRO 2.0

- Cabinet length: 680 mm
- With gas springs, making it easier to open and close door
- With lock

10 kg

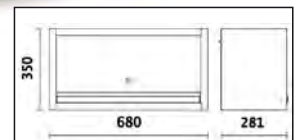

C45PRO 2.0 PM

1 045000302

## SSPE

under-cabinet support for power tools

- For use only under suspended cabinet C45PRO 2.0 PM (workshop equipment C45PRO 2.0)
- With 5 convenient slots for accommodating power tools
- Dimensions: 680 x 280 x 150 mm

6 kg



SSPE

1 088880482

## C45PRO 2.0 PML

wall-mounted cabinet, long, for workshop equipment combination C45PRO 2.0

- Cabinet length: 1360 mm
- With gas springs, making it easier to open and close door
- With lock

17 kg

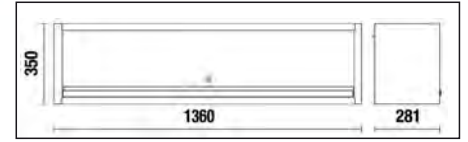

C45PRO 2.0 PML

1 045000303

## C45PRO 2.0 AS1

sheet metal single-door tool cabinet with bracket, for workshop equipment combination C45PRO 2.0

- 4 removable, vertically adjustable shelves
- Convenient folding clothes rail under first shelf
- With lock
- Sheet metal door can be installed with right or left opening
- Interior dimensions: 590x430 mm
- With vertically adjustable feet

57,5 kg

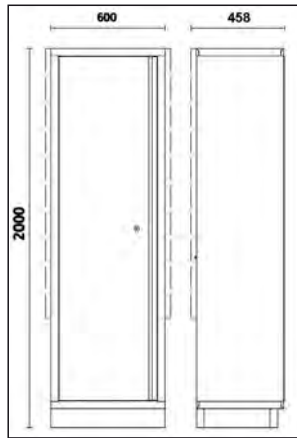

C45PRO 2.0 AS1

1 045000451

## C45PRO 2.0 A1/R600

interior shelf for tool cabinet C45PRO AS1

2,5 kg



C45PRO 2.0 A1/R600

1 045000466

## C45PRO 2.0 A1/RB600

interior shelf for tool cabinet C45PRO 2.0 AS1, with clothes rail

3,3 kg



C45PRO 2.0 A1/RB600

1 045000467

## C45PRO 2.0 AS2

sheet metal two-door tool cabinet with bracket, for workshop equipment combination C45PRO 2.0

- 4 removable, vertically adjustable shelves
- With lock
- Sheet metal door can be installed with right or left opening
- Interior dimensions: 910x430 mm
- With vertically adjustable feet

80 kg

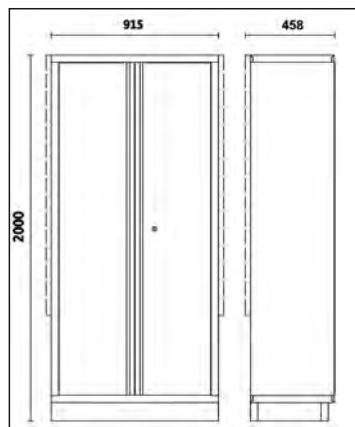

C45PRO 2.0 AS2

1 045000481

## C45PRO 2.0 AS2/3C

sheet metal two-door tool cabinet with 3 drawers and bracket, for workshop equipment combination C45PRO 2.0

- 4 removable, vertically adjustable shelves
- **Supplied complete with 3-drawer (681x360 mm) module**
- Front lock
- Sheet metal door can be installed with right or left opening
- Interior dimensions: 910x430 mm
- With vertically adjustable feet

100,5 kg

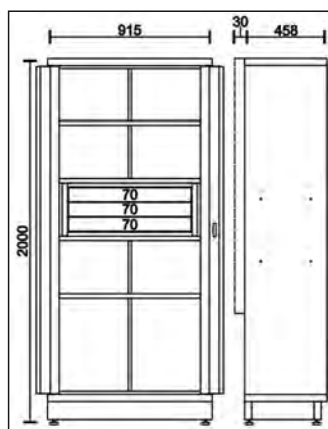
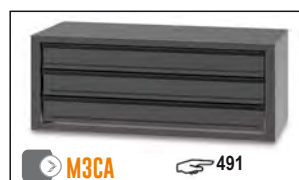

C45PRO 2.0 AS2/3C

1 045000482

## C45PRO 2.0 A2/R915

Interior shelf for tool cabinet C45PRO 2.0 AS2

4,5 kg

50 kg

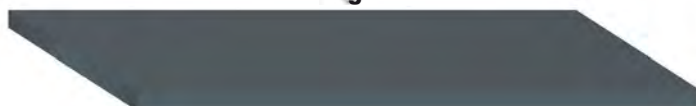

C45PRO 2.0 A2/R915

1 045000496

## C45STR

coloured adhesive tape, for workshop equipment combination C45PRO 2.0

- Allows tailoring of colour of horizontal and vertical inserts in workshop equipment combination C45PRO 2.0



	L m		
C45STR-O/2011	30	1	045000911
C45STR-G/9006	25	1	045000912
C45STR-R/3000	25	1	045000913
C45STR-B/5015	25	1	045000914
C45STR-Y/1023	25	1	045000915
C45STR-V/6029	25	1	045000916

## S4CB

wide-span shelving, 4 shelves,  
basic shelving

A must-have for optimizing and efficiently managing products and tools in warehouses, workshops, offices and sales points. Made from sturdy sheet steel, it is ideal for accommodating several different types of goods.

- Carrying capacity of each shelf: 250 kg
- Total carrying capacity: 1,000 kg
- Can be fixed to floor

82 kg



	mm		
S4CB	1552x600x1803mm	1	088880490

## S4CA

wide-span shelving, 4 shelves,  
additional shelving

Additional shelving extends basic shelving to increase storage space. Made from sturdy sheet steel, it is ideal for accommodating several different types of goods.

- Carrying capacity of each shelf: 250 kg
- Total carrying capacity: 1,000 kg
- Can be fixed to floor

72 kg



S4CA		1	088880495



# ACCESSORIES RSC55 - RSC50 2.0 - C45PRO 2.0

		5000 RSC50 2.0/PLED-ST	5000 RSC50 2.0/PLED	5000 RSC50 2.0/ASL	5000 RSC50 2.0/CTR
	A	1x	-	1x	-
	B	-	1x	1x	1x
	A	1x	1x	1x	-
	B	-	2x	1x	1x
	A	1x	2x	1x	-
	B	-	3x	1x	1x

## 5000 RSC50 2.0/PLEDC

aluminium profile with LED strip, for workshop equipment combinations

To be applied under worktops, under/in suspended cabinets, under shelves and linear/corner guards, to light working areas.

Features:

- 6.5W IP20 LED strip; length: 50 cm
- Supplied complete with cables
- Convenient fixing through magnets

80 g



5000 RSC50 2.0/PLEDC

1 050001712

## 5000 RSC50 2.0/PLED-ST

aluminium profile with LED strip and SOFT TOUCH switch, for workshop equipment combination

To be applied under worktops, under/in suspended cabinets, under shelves and linear/corner guards, to light working areas.

Features:

- 6.5W IP20 LED strip; length: 50 cm
- On/off and brightness adjustment SOFT TOUCH switch
- Supplied complete with cables
- Convenient fixing through magnets

80 g



5000 RSC50 2.0/PLED-ST

1 050001715

## 5000 RSC50 2.0/ASL

power supplier for LED strip, for workshop equipment combination

Features:

- 24VDC 22W power supplier
- Can supply power to max. 3 6.5W LED strips

210 g



5000 RSC50 2.0/ASL

1 050001716

## 5000 RSC50 2.0/CTR

LED strip controller, with RF remote control, for workshop equipment combination

For use only with LED strip item 5000 RSC50 2.0/PLEDC

Kit contents:

1 mini receiver

1 wireless RF remote control

Specifications of mini receiver:

Input voltage: 5V -24VDC

Rated output current: 5A

Peak output current: 12A

Operating temperature: -20 °C ÷ +35 °C

Specifications of RF remote control:

ON/OFF button

BRIGHT +/- button: allows manual brightness adjustment

25%/50%/100% button: allows automatic brightness adjustment

Battery: 3V CR2025 (included)

Dimensions: 86 (L) x 40 (W) x 7 (H) mm

Integrated features:

- Memory
- Mode (manual/automatic brightness)
- Brightness adjustment



25 g

5000 RSC50 2.0/CTR



1



050001721

## CPMB/3C

workbench small parts containers with 3 drawers

- Outer frame made of PP
- Small parts drawers made of PET
- Stackable

Specifications of drawers:

• Interior drawer dimensions: 160x107x105h mm

• Unbreakable

• Glass effect transparency unchanged over time

• Scratchproof

• Resistant to oil, acids and aggressive chemicals

• Also suitable for use in food products



2,3 kg

CPMB/3C



1



088880443

## KIT 6VC/3C

kit of 6 removable trays for small parts containers CPMB/3C

1,1 kg



6x



KIT 6VC/3C



1



088880453

## CPMB/5C

workbench small parts containers with 5 drawers

- Outer frame made of PP
- Small parts drawers made of PET
- Stackable

Specifications of drawers:

- Interior drawer dimensions: 90x86x62h mm
- Unbreakable
- Glass effect transparency unchanged over time
- Scratchproof
- Resistant to oil, acids and aggressive chemicals
- Also suitable for use in food products

1,7 kg

CPMB/5C

1 088880445



## KIT 10VC/5C

kit of 10 removable trays for small parts containers CPMB/5C

800 g

KIT 10VC/5C

1 088880455



## PM/5C

wall-mounted small parts holder with 5 tote trays, made from plastic, with support

- Interior dimensions: 95x120 mm
- Can be used with tool wall systems: C45PRO, RSC50 2.0 e RSC55 2.0

2,7 kg

PM/5C

1 088880450



## PM/6C

wall-mounted smallwares holder with 6 tote trays, made from plastic, with support

- Interior dimensions: 80x60 mm
- Can be used with tool wall systems C45PRO 2.0, RSC50 2.0 and RSC55

970 g

PM/6C

1 088880440



## CP

wall-mounted bottle rack, made from steel

- Can be used with wall-mounted tool panels
- Supplied complete with 2 supports

533 g

CP

1 088880470

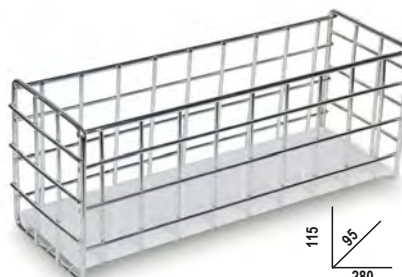

## SPC

computer wall bracket

- Matches tool wall systems RSC55, RSC50 2.0 and C45PRO 2.0
- Dimensions 398x243x138 mm

1,5 kg



SPC

1 088880480

## SP5S

wall-mounted support with 5 compartments

- Made from sheet metal
- 5 tool compartments varying in height
- Dimensions: 260x60x290 mm

1,8 kg



SP5S

1 088880475

## M3CA

3-drawer module  
for two-door tool cabinets C45PRO AS2 and RSC50 A2

- 3 fully removable (661x360 mm), with ball bearing slides
- Drawer height: 78 mm
- Drawer bases protected by foamed rubber mats
- Supplied complete with assembly kit

20,5 kg



295  
400  
750

M3CA

1 088880485

# Beta