



RSC22

portable tool chest with 3 drawers

Main features:

- 3 drawers (588x277 mm) with ball bearing slides:
- 1 drawer, 50 mm high
- 2 drawers, 70 mm high.
- Front centralized lock.
- Retractable side handles for ease of handling.

19 kg



h		
	50 mm	25 kg
	70 mm	25 kg

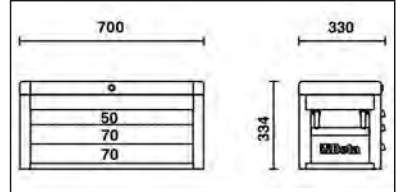
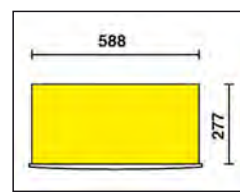

RSC22-O	RAL 2011	1	022003001
RSC22-R	RAL 3000	1	022003003
RSC22-A	RAL 7016	1	022003007

RSC23

portable tool chest
with 5 drawers

Main features:

- 5 drawers (588x277 mm)
- with ball bearing slides:
- 2 drawers, 50 mm high
- 3 drawers, 70 mm high.
- Front centralized lock.
- Retractable side handles for ease of handling.

📦 26 kg



RSC23-A



RSC23-R



RSC23-O



h	max
50 mm	25 kg
70 mm	25 kg

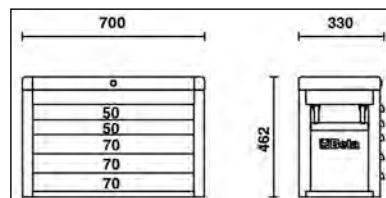
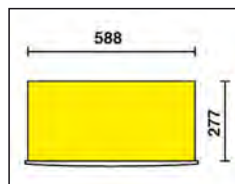

RSC23-O	RAL 2011	1	023003001
RSC23-R	RAL 3000	1	023003003
RSC23-A	RAL 7016	1	023003007

CD23S

Caddy trolley

Main features:

- ABS-coated worktop designed to match tool chests C22S, C23S, C23SC, C23ST
- Removable handle, can be stored underneath chassis.
- Four castors, Ø 100 mm: 2 fixed and 2 steering (one with brake).
- Maximum load capacity: 250 kg.

📦 14 kg



CD23S	1	023000610
-------	---	-----------

RSC23C

portable tool chest
with 8 drawers

Main features:

- 8 drawers (588x277 mm) with ball bearing slides:
- 4 drawers, 50 mm high
- 3 drawers, 70 mm high
- 1 drawer, 100 mm high.
- Front centralized lock.
- Retractable side handles for ease of handling.

📦 28 kg



RSC23C-A



RSC23C-R



RSC23C-O



h	max
50 mm	25 kg
70 mm	25 kg

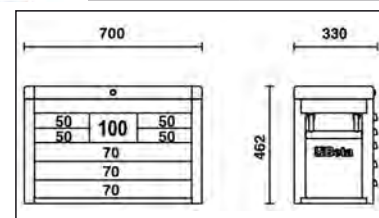
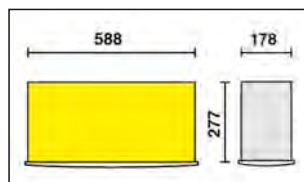

RSC23C-O	RAL 2011	1	023003011
RSC23C-R	RAL 3000	1	023003013
RSC23C-A	RAL 7016	1	023003017

RSC23T

portable tool chest
with 5 drawers

Main features:

- 5 drawers (588x367 mm) with ball bearing slides:
- 5 drawers, 70 mm high.
- Front centralized lock.
- Can be fitted with kit of 4 castors and 1 handle (2300ST/KIT)

36 kg



RSC23T-A



RSC23T-B



RSC23T-G



RSC23T-N



RSC23T-R



RSC23T-O



RSC23T-FO

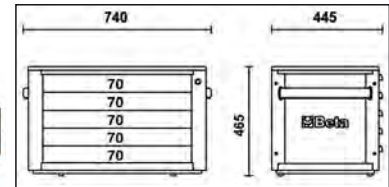
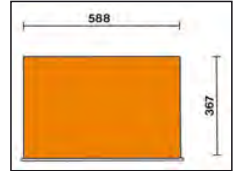

RSC23T-FO	RAL 2011	1	023003020
RSC23T-O	RAL 2011	1	023003021
RSC23T-G	RAL 9006	1	023003022
RSC23T-R	RAL 3000	1	023003023
RSC23T-B	RAL 5015	1	023003026
RSC23T-A	RAL 7016	1	023003027
RSC23T-N	RAL 9005	1	023003029

2300ST/KIT

kit with 4 castors and 1 handle for C23ST

- Four castors, Ø 125 mm:
- 2 fixed and 2 steering (one with brake).
- Telescopic handle

6,5 kg

2300ST/KIT	1	023000950
------------	---	-----------



Beta



MOBILE ROLLER CAB RSC24

Beta RSC24

NEW WORKTOP FIRMER AND STURDIER MORE CONVENIENT AND FUNCTIONAL MORE MODERN

- Drawers with ball bearing slides
- Drawer bases protected by foamed rubber mats
- Each drawer can accommodate up to 4 EVA foam or ABS thermoformed trays
- New ABS reinforced worktop, designed to support tool chests RSC22, RSC23, RSC23C and RSC23T
- Multi-purpose top with anti-fall edges and eight holes for accommodating screwdrivers
- Front centralized safety lock
- Four castors Ø 125 mm: 2 fixed and 2 steering (one with brake)
- Static load capacity: 800 kg

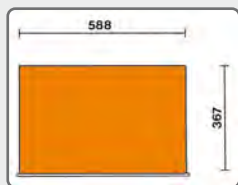
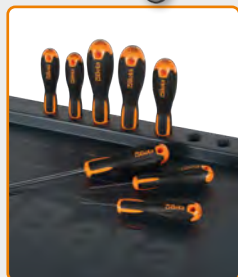

Available colours:

FO	RAL 2011	RAL 2011
O	RAL 7016	RAL 2011
G	RAL 7016	RAL 9006
R	RAL 7016	RAL 3000
B	RAL 7016	RAL 5015
A	RAL 7016	RAL 7016
N	RAL 9005	RAL 9005

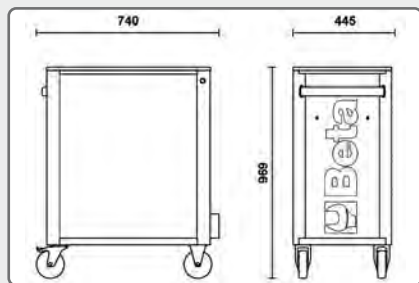

Available models:

- RSC24/5 (5 drawers)
- RSC24/6 (6 drawers)
- RSC24/7 (7 drawers)
- RSC24/8 (8 drawers)



Available accessories:

2400 RSC24/PD-A
2400 RSC24/PD-N



2400 RSC24/PL



2400 RSC24/SPC



2400 RSC24/PF-A
2400 RSC24/PF-N



2400 RSC24/PF



2400 RSC24/AXLP/VL



2400 RSC24/MP



2400 RSC24/PC-A
2400 RSC24/PC-N

RSC24/7

mobile roller cab with 7 drawers

Main features:

- 7 fully removable drawers (588x367 mm), with ball bearing slides:

- 5 drawers, 70 mm high
- 1 drawer, 140 mm high
- 1 drawer, 210 mm high

63 kg

RSC24/7-FO	1	024004070
RSC24/7-O	1	024004071
RSC24/7-G	1	024004072
RSC24/7-R	1	024004073
RSC24/7-B	1	024004076
RSC24/7-A	1	024004077
RSC24/7-N	1	024004079



RSC24/7-O

Beta RSC24



RSC24/7-FO



RSC24/7-A



RSC24/7-B



RSC24/7-G



RSC24/7-N



RSC24/7-R



h	max
70 mm	25 kg
140 mm	30 kg
210 mm	30 kg



RSC24/5

mobile roller cab with 5 drawers

Main features:

- 5 fully removable drawers (588x367 mm), with ball bearing slides:
- 2 drawers, 70 mm high
- 2 drawers, 140 mm high
- 1 drawer, 280 mm high

60 kg

		
RSC24/5-FO	1	024004050
RSC24/5-O	1	024004051
RSC24/5-G	1	024004052
RSC24/5-R	1	024004053
RSC24/5-B	1	024004056
RSC24/5-A	1	024004057
RSC24/5-N	1	024004059



RSC24/5-O

Beta RSC24



h	max
70 mm	25 kg
140 mm	30 kg
280 mm	35 kg



RSC24/6

mobile roller cab with 6 drawers

Main features:

- 6 fully removable drawers (588x367 mm), with ball bearing slides:
- 4 drawers, 70 mm high
- 1 drawer, 140 mm high
- 1 drawer, 280 mm high

62 kg

		
RSC24/6-FO	1	024004060
RSC24/6-O	1	024004061
RSC24/6-G	1	024004062
RSC24/6-R	1	024004063
RSC24/6-B	1	024004066
RSC24/6-A	1	024004067
RSC24/6-N	1	024004069



RSC24/6-O

Beta RSC24



h	max
70 mm	25 kg
140 mm	30 kg
280 mm	35 kg



RSC24/8

mobile roller cab with 8 drawers

Main features:

- 8 fully removable drawers (588x367 mm), with ball bearing slides:
- 6 drawers, 70 mm high
- 2 drawers, 140 mm high

66 kg

		
RSC24/8-FO	1	024004080
RSC24/8-O	1	024004081
RSC24/8-G	1	024004082
RSC24/8-R	1	024004083
RSC24/8-B	1	024004086
RSC24/8-A	1	024004087
RSC24/8-N	1	024004089



RSC24/8-O

Beta RSC24



h	max
70 mm	25 kg
140 mm	30 kg

RSC24A/6

mobile roller cab with 6 drawers,
with anti-tilt system

Main features:

- 6 fully removable drawers (588x367 mm), with ball bearing slides:
- 4 drawers, 70 mm high
- 1 drawer, 140 mm high
- 1 drawer, 280 mm high

62 kg

RSC24A/6-O	1	024004161
RSC24A/6-R	1	024004163
RSC24A/6-A	1	024004167



Beta RSC24



RSC24A/6-A



RSC24A/6-R



h	max
70 mm	25 kg
140 mm	30 kg
280 mm	35 kg

RSC24A/7

mobile roller cab with 7 drawers,
with anti-tilt system

Main features:

- 7 fully removable drawers (588x367 mm), with ball bearing slides:
- 5 drawers, 70 mm high
- 1 drawer, 140 mm high
- 1 drawer, 210 mm high

63 kg

RSC24A/7-O	1	024004171
RSC24A/7-R	1	024004173
RSC24A/7-A	1	024004177



Beta RSC24



RSC24A/7-A



RSC24A/7-R



h	max
70 mm	25 kg
140 mm	30 kg
210 mm	30 kg

RSC24A/8

mobile roller cab with 8 drawers,
with anti-tilt system

Main features:

- 8 fully removable drawers (588x367 mm), with ball bearing slides:
- 6 drawers, 70 mm high
- 2 drawers, 140 mm high

66 kg

RSC24A/8-O	1	024004181
RSC24A/8-R	1	024004183
RSC24A/8-A	1	024004187



Beta RSC24



RSC24A/8-A



RSC24A/8-R



h	max
70 mm	25 kg
140 mm	30 kg

MOBILE ROLLER CAB RSC24AXL

Beta RSC24

LONG VERSION:

each drawer can accommodate up to 6 EVA foam or ABS thermoformed trays



ANTI-TILT SYSTEM: PREVENTS SEVERAL DRAWERS FROM BEING SIMULTANEOUSLY OPENED

- Drawers with ball bearing slides
- New ABS reinforced worktop with anti-fall edges, eight holes for accommodating screwdrivers and 6 tote trays.
- Sturdy nylon front, with built-in label holder
- Four castors Ø 125 mm: 2 fixed and 2 steering (one with brake)
- Static load capacity: 1000 kg
- Drawer bases protected by foamed rubber mats
- Integrated side bottle holder
- Front centralized safety lock

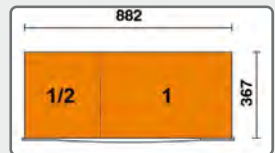
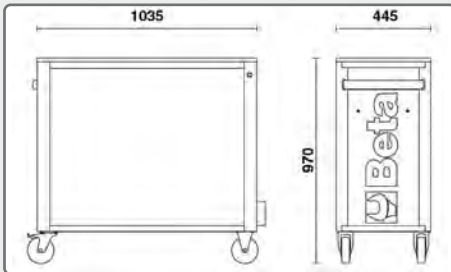

Available colours:

O	RAL 7016	RAL 2011
R	RAL 7016	RAL 3000
A	RAL 7016	RAL 7016

Available accessories:



RSC24AXL/7

mobile roller cab with 7 drawers, with anti-tilt system, long model

Main features:

- 7 fully removable drawers (882x367 mm), with ball bearing slides:
 - 5 drawers, 70 mm high
 - 1 drawer, 140 mm high
 - 1 drawer, 210 mm high

1000 kg



Beta RSC24



h	max
70 mm	30 kg
140 mm	35 kg
210 mm	35 kg



84 kg

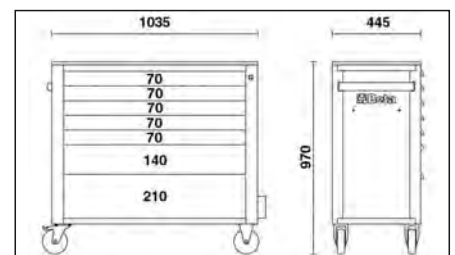
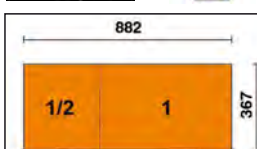

RSC24AXL/7-O	1	024004271
RSC24AXL/7-R	1	024004273
RSC24AXL/7-A	1	024004277

RSC24AXL/8

mobile roller cab with 8 drawers,
with anti-tilt system,
long model

Main features:

- 8 fully removable drawers (882x367 mm), with ball bearing slides:
 - 6 drawers, 70 mm high.
 - 2 drawers, 140 mm high.

88 kg

RSC24AXL/8-O	1	024004281
RSC24AXL/8-R	1	024004283
RSC24AXL/8-A	1	024004287

1000 kg



RSC24AXL/8-O

Beta RSC24



RSC24AXL/8-A



RSC24AXL/8-R

h	max
70 mm	30 kg
140 mm	35 kg

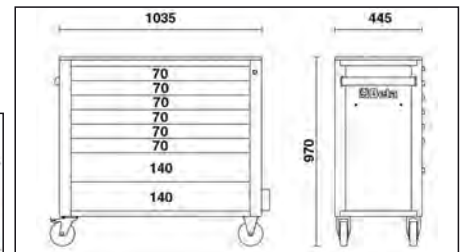

RSC24AXL/9

mobile roller cab with 9 drawers,
with anti-tilt system,
long model

Main features:

- 9 fully removable drawers (882x367 mm), with ball bearing slides:
 - 8 drawers, 70 mm high
 - 1 drawer, 140 mm high.

90 kg

RSC24AXL/9-O	1	024004291
RSC24AXL/9-R	1	024004293
RSC24AXL/9-A	1	024004297

1000 kg



RSC24AXL/9-O

Beta RSC24



RSC24AXL/9-A



RSC24AXL/9-R

h	max
70 mm	30 kg
140 mm	35 kg

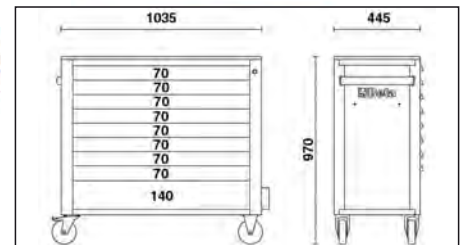
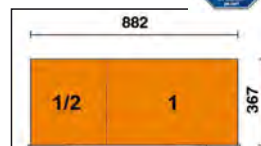

RSC24AXLP/7

mobile roller cab with 7 drawers, with wood worktop and anti-tilt system, long model

Main features:

- 7 fully removable drawers (882x367 mm), with ball bearing slides:
 - 5 drawers, 70 mm high
 - 1 drawer, 140 mm high
 - 1 drawer, 210 mm high
- Multi-ply wood worktop with holes for a vice 1599F/100 or 1599GI/100 (to be ordered separately)
- Sturdy nylon front, with built-in label holder
- Drawer bases protected by foamed rubber mats
- 4 castors, Ø 125 mm: 2 fixed and 2 steering (one with brake)
- Front centralized safety lock
- Static load capacity: 1.100 kg
- Built-in side bottle holder (can be applied on both sides)
- Built-in paper roll holder
- Each drawer can accommodate up to 6 EVA foam or ABS thermoformed trays



105 kg

h	max
70 mm	30 kg
140 mm	35 kg
210 mm	35 kg

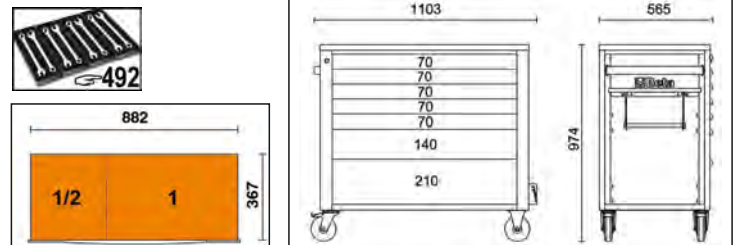
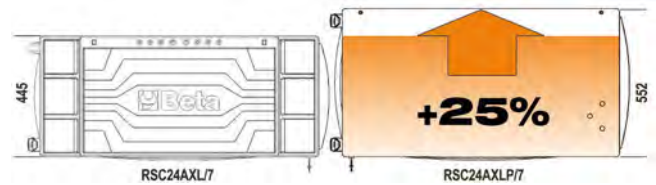

RSC24AXLP/7-O	1	024004571
RSC24AXLP/7-R	1	024004573
RSC24AXLP/7-A	1	024004577

2400 RSC24AXLP/PF

perforated tool panel with supports, for roller cab RSC24AXLP/7, RSC24L, RSC24L-CAB

50-hook GPS kit included

4,5 kg



2400 RSC24AXLP/PF	1	024004992
-------------------	---	-----------

Beta

RSC24AXXL

mobile roller cab with 8 drawers and anti-tilt system, long model

Main features:

- 1 fully removable drawer (1,176x367 mm), with ball bearing slides
- 7 fully removable drawers (882x367 mm), with ball bearing slides:
 - 6 drawers 70 mm high
 - 1 drawer 140 mm high
- Worktop made from stainless steel coated MDF, with holes for vice item 1599F/125 or 1599G/125 (to be ordered separately) and 6 tote trays
- Sturdy nylon fronts, with built-in label holders
- Drawer bases protected by foamed rubber mats
- Removable side compartment, with ball bearing slides, with shelf and lock
- 4 castors, Ø 150 mm: 2 fixed and 2 steering with brakes
- 3 safety locks
- Built-in paper roll holder
- Built-in bottle holder
- Static load capacity: 1,100 kg

• Following trays can be added:

- up to 8 EVA foam or ABS thermoformed trays in drawer 1,176x367 mm
- up to 6 EVA foam or ABS thermoformed trays in drawer 882x367 mm

1100 kg

Beta RSC24



RSC24AXXL/O



h	max
70 mm (1.176x367 mm)	40 kg
70 mm (882x367 mm)	30 kg
140 mm (882x367 mm)	35 kg



RSC24AXXL/R



RSC24AXXL/A

131 kg

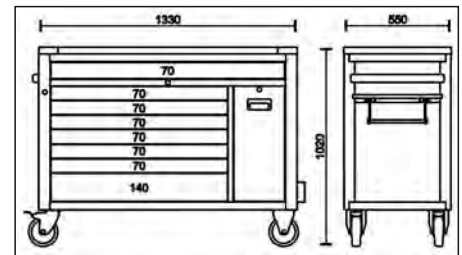
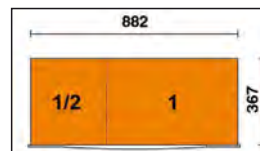
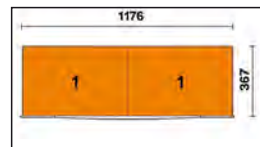

RSC24AXXL-O	1	024004781
RSC24AXXL-R	1	024004783
RSC24AXXL-A	1	024004787

2400 RSC24AXXL/PF

perforated tool panel with supports, for mobile roller cab RSC24AXXL

3,8 kg



570

395
2
1305

2400 RSC24AXXL/PF	1	024004998
-------------------	---	-----------

2400 RSC24AXLP/CPR

waste bin for roller cab RSC24AXLP/7, RSC24AXXL

5 kg



2400 RSC24AXLP/CPR	1	024004993
--------------------	---	-----------

2400 RSC24AXLP/VL

side tool tray for roller cab RSC24, RSC24A, RSC51, RSC24AXLP/7, RSC24AXXL

4 kg

2400 RSC24AXLP/VL

1 024004995



2400 RSC24/PC

paper roll holder for mobile roller cab RSC24, RSC24A, RSC24AXL, RSC51

0,3 kg

2400 RSC24/PC-A
2400 RSC24/PC-N

1 024004903
1 024004904



RAL7016 2400 RSC24/PC-A
RAL9005 2400 RSC24/PC-N



2400 RSC24/PD

document holder for mobile roller cab RSC24, RSC24A, RSC24AXL

1,2 kg

2400 RSC24/PD-A
2400 RSC24/PD-N

1 024004907
1 024004908

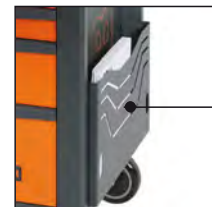

RAL7016 2400 RSC24/PD-A
RAL9005 2400 RSC24/PD-N



2400 RSC24/PF

perforated tool panel with supports, for roller cab RSC24, RSC24A, RSC51

50-hook GPS kit included

2,3 kg

2400 RSC24/PF

1 024004902

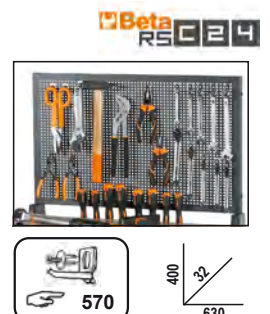

2400 RSC24/PF-

bottle holder for mobile roller cab RSC24, RSC24A, RSC24AXL

0,5 kg

2400 RSC24/PF-A
2400 RSC24/PF-N

1 024004905
1 024004906

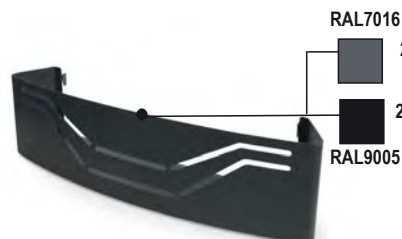

2400 RSC24/PL

wood worktop for roller cab RSC24, RSC24A, RSC24AXL, RSC51

4,3 kg

2400 RSC24/PL

1 024004901



2400 RSC24/SPC

computer bracket for mobile roller cab RSC24, RSC24A, RSC51, RSC24AXLP/7, RSC24AXXL

- With removable drawer
- Cannot be used with model RSC24AXL

3,1 kg

2400 RSC24/SPC

1 024004909



2400 RSC24/MP

folding shelf for items RSC24, RSC24A, RSC51, RSC24AXLP/7, RSC24AXXL

- For use as additional worktop
- Worktop dimensions: 390x440 mm, protected by an anti-oil and anti-petrol rubber mat
- Load capacity: 20 kg

3,4 kg

2400 RSC24/MP

1 024004900



2499PF

bottle holder

- Can match roller cabs C38, C38A

2,5 kg

2499PF-O

1 024990210

2499PF-G

1 024990219

2499PF-R

1 024990230

2499PF O

2499PF G

2499PF R



2499PF/M

universal magnetic bottle holder

2,2 kg

2499PF/M

1 024990050



2499PC

paper roll holder

- Matches Tank trolleys C25.

2,2 kg

2499PC

1 024990090



RSC24L/7

mobile roller cab
with 7 drawers
and side shelves

Main features:

- 7 drawers (588x367 mm)
with ball bearing slides:
5 drawers, 70 mm high
1 drawer, 140 mm high
1 drawer, 210 mm high.
- Drawer bases protected by foamed rubber mats.
- 4 castors, Ø 125 mm:
2 fixed and 2 steering with brakes.
- Front centralized lock.
- Static load capacity: 1,100 kg.
- Multi-ply wood worktop with holes
for a vice
(1599F/100 - 1599GI/100, to be ordered separately).
- Side compartment with vertically adjustable shelf.
- Built-in paper roll holder.
- Double rear bottle holder.
- Built-in side bottle holder

80 kg

RSC24L/7-O	RAL 2011	1	024004371
RSC24L/7-R	RAL 3000	1	024004373
RSC24L/7-A	RAL 7016	1	024004377

Beta RSC24

1100 kg



h	max
70 mm	25 kg
140 mm	30 kg
210 mm	30 kg

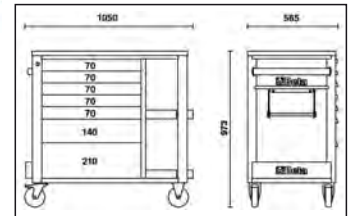
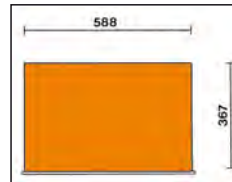

RSC24L-CAB

mobile roller cab
with 7 drawers
and tool cabinet

Main features:

- 7 drawers (588x367 mm)
with ball bearing slides:
5 drawers, 70 mm high
1 drawer, 140 mm high
1 drawer, 210 mm high.
- Drawer bases protected by foamed rubber mats.
- 4 castors, Ø 125 mm:
2 fixed and 2 steering with brakes.
- Front centralized lock.
- Side tool cabinet with lockable door and vertically adjustable interior shelf.
- Static load capacity: 1,100 kg.
- Multi-ply wood worktop with holes
for a vice
(1599F/100, to be ordered separately).
- Built-in paper roll holder.
- Double rear bottle holder.
- Built-in side bottle holder

82 kg

RSC24L-CAB/O	RAL 2011	1	024004471
RSC24L-CAB/R	RAL 3000	1	024004473
RSC24L-CAB/A	RAL 7016	1	024004477

Beta RSC24

1100 kg



h	max
70 mm	25 kg
140 mm	30 kg
210 mm	30 kg

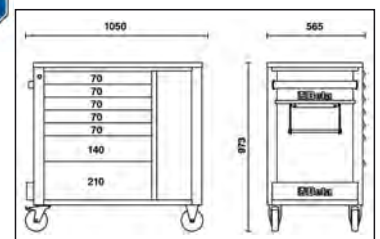
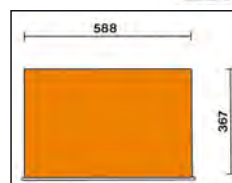

C04TSS-7

mobile roller cab with seven drawers, made entirely of stainless steel, Non-marking wheels

Main features:

- Seven drawers (570 x 410 mm) with ball bearing slides;
- 6 drawers, 83 mm high;
- 1 drawer, 170 mm high;
- 4 castors Ø 125 mm
- 2 fixed and 2 steering (two with brakes);
- Front centralized lock;
- Frame made entirely of stainless steel AISI 304
- Castors, supports, ball bearings, drawer interiors and guides made of stainless steel
- Drawer handles made of aluminium



700 kg



63 kg

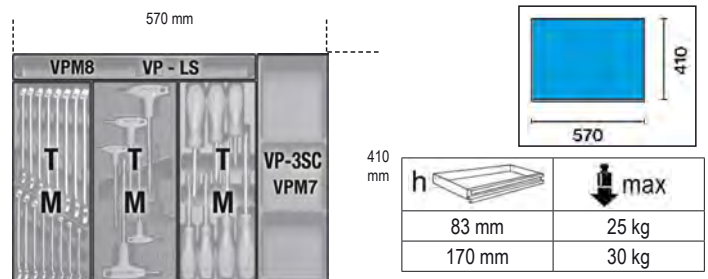

C04TSS/7

1 024003077 296

C25

Tank trolley with shelf

Main features:

- Foldaway lid.
- 1 sliding drawer.
- Tool tray protected by foamed rubber mats.
- Shelves protected by oil and fuel proof mats.
- Four castors 100 mm in Ø:
- 2 fixed and 2 swivelling (one with brake).
- Safety lock.
- One more shelf M4 can be added on the opposite side.
- Empty thermoformed tray for 1/2" sockets and accessories (024990104).
- Paper roll holder item 2499PC can also be included



31,5 kg

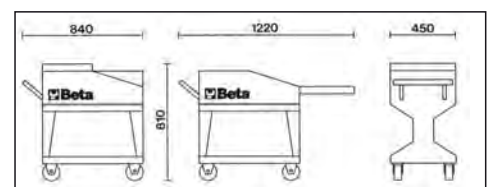

C25

1 025000001

C27S

folding tool trolley for outdoor jobs

Folding tool trolley. Its unique patented design guarantees an effortless transport.

Features:

- 2 drawers, 588x277 mm, with ball bearing slides, for two-way opening
- Large lower object compartment, 588x277x220 mm
- Sheet metal frame
- 2 fixed castors, Ø 160 mm, and 2 steering castors with brake, Ø 100 mm
- Thermoplastic worktop with 6 built-in tool trays
- Centralized lock
- Can accommodate drawer partitions and MC foam tool trays

20 kg



C27S-O



C27S-G



C27S-R



h	max
70 mm	20 kg

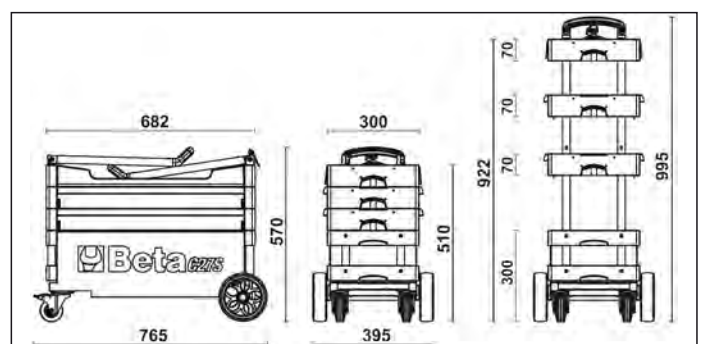
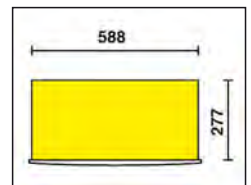

C27S-O	RAL 2011	1	027000201
C27S-G	RAL 7016	1	027000202
C27S-R	RAL 3000	1	027000203

RSC28

SuperTank trolley with wood worktop and 10 drawers

Main features:

- 10 drawers (588x367 mm) with ball bearing slides.
- Quick, safe system for opening and closing drawers, with nylon and fibreglass front.
- 5 side drawers:
 - 4 drawers, 70 mm high
 - 1 drawer, 210 mm high.
- 5 front drawers:
 - 4 drawers, 70 mm high
 - 1 drawer, 210 mm high.
- Drawer bases protected by foamed rubber mats.
- 4 high-capacity castors, Ø 150 mm:
- 2 fixed and 2 steering with brakes.
- 2 centralized safety locks.
- 3 front tool drawers.
- Multi-ply wood worktop with holes for a vice (1599F/150 - 1599GI/150, to be ordered separately).
- Built-in tool compartment.
- Side compartment with foldaway door with lock.
- Built-in bottle holders.
- 135-mm-high storage compartment with plastic-covered base.
- Static load capacity: 1,200 kg.

1200 kg



RSC28-O

 130 kg



RSC28-A



RSC28-R



h	max
70 mm	25 kg
210 mm	30 kg

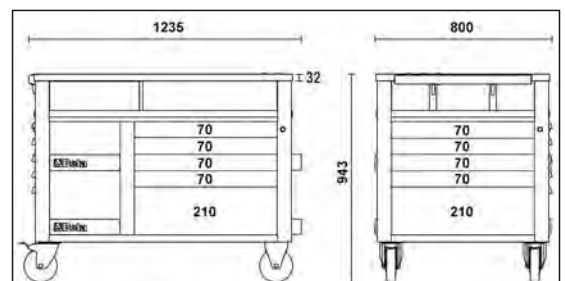
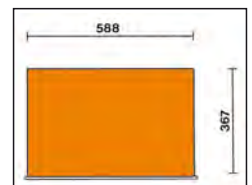

RSC28-O	RAL 2011	1	028003001
RSC28-R	RAL 3000	1	028003003
RSC28-A	RAL 7016	1	028003007

C30M

MaxiTank mobile workbench

Main features:

- 5 front drawers with ball bearing slides:
 - 3 drawers (367x610 mm), 90 mm high
 - 1 drawer (588x610 mm), 90 mm high
 - 1 drawer (588x610 mm), 180 mm high.
- Quick opening system with aluminium front.
- Drawer bases protected by foamed rubber mats.
- Can be fitted with thermoformed trays.
- One hydraulic jack, designed to lift front part effortlessly, thus allowing easy transportation.
- 4 high-capacity castors:
 - 2 steering, front, Ø 150 mm
 - 2 fixed, rear, Ø 170 mm.
- Oil-proof, rubber-coated worktop, 1300x800 mm, with drain hole for fluid collection in a small tank.
- Storage compartment, 720x250x1300 mm, with PVC-coated worktop and front sliding panels.
- Centralized lock for drawers and panels.
- 3 built-in side bottle holders.
- Built-in paper roll holder
- Static load capacity: 1,800 kg.
- Can accommodate a multi-ply wood worktop (3000M/PLM), to be ordered separately
- Can accommodate vice 1599F/150 or 1599GI/150(to be ordered separately).

1800 kg



200 kg



h	max
90 mm	30 kg
180 mm	35 kg

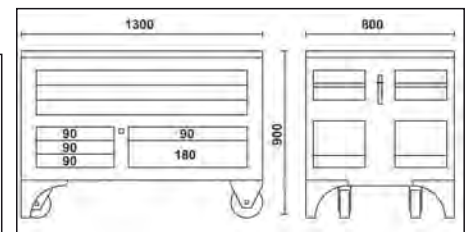
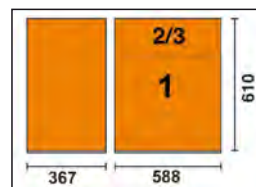

C30M

1 030000300

3000M/PLM

wood worktop for C30M,
with holes for a vice (1599F/150 - 1599GI/150)



1240x740x26 mm

10 kg

3000M/PLM

1 030000350



INDUSTRIAL TOOL CHEST C35



FUNCTIONAL AND STURDY

- Pull-out drawers
- Front centralized safety lock
- Can accommodate a worktop and drawer partitions, to be ordered separately
- Static load capacity: 1200 kg

Available models:

- C35/6GM (6 drawers)
- C35/7GM (7 drawers)
- C35/8GM (8 drawers)
- C35/9GM (9 drawers)

Available accessories:

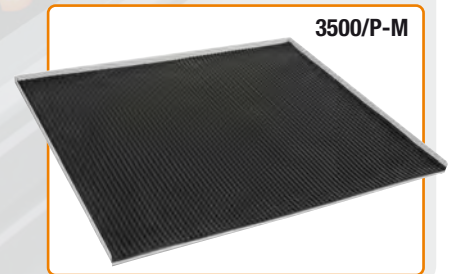

C35/6GM

industrial tool chest with 6 drawers

Main features:

- 6 pull-out drawers (600x447 mm):
 - 2 drawers, 75 mm high
 - 1 drawer, 100 mm high
 - 1 drawer, 150 mm high
 - 1 drawer, 200 mm high
 - 1 drawer, 300 mm high
- Front centralized safety lock.
- Can accommodate a worktop and drawer partitions, to be ordered separately



h	max
75 mm	70 kg
100 mm	70 kg
150 mm	70 kg
200 mm	70 kg
300 mm	70 kg

75 kg

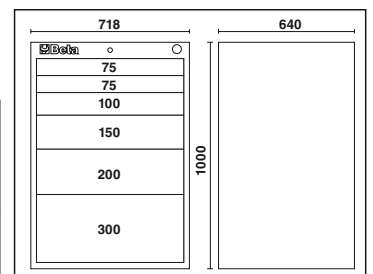
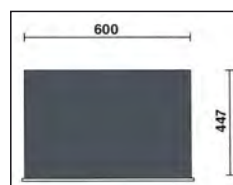

C35/6GM

1 035000162

C35/76M

industrial tool chest with 7 drawers

Main features:

- 7 pull-out drawers (600x447 mm):
2 drawers, 75 mm high
1 drawer, 100 mm high
3 drawers, 150 mm high
1 drawer, 200 mm high
- Front centralized safety lock.
- Can accommodate a worktop and drawer partitions, to be ordered separately

82 kg

C35/76M



1 035000172



h	max
75 mm	70 kg
100 mm	70 kg
150 mm	70 kg
200 mm	70 kg

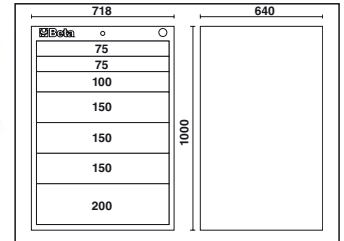

C35/86M

industrial tool chest with 8 drawers

Main features:

- 8 pull-out drawers (600x447 mm):
4 drawers, 75 mm high
1 drawer, 100 mm high
2 drawers, 150 mm high
1 drawer, 200 mm high
- Front centralized safety lock.
- Can accommodate a worktop and drawer partitions, to be ordered separately

86 kg

C35/86M



1 035000182



h	max
75 mm	70 kg
100 mm	70 kg
150 mm	70 kg
200 mm	70 kg

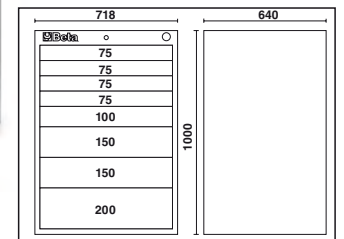

C35/96M

industrial tool chest with 9 drawers

Main features:

- 9 pull-out drawers (600x447 mm):
6 drawers, 75 mm high
3 drawers, 150 mm high
- Front centralized safety lock.
- Can accommodate a worktop and drawer partitions, to be ordered separately

91 kg

C35/96M



1 035000192



h	max
75 mm	70 kg
150 mm	70 kg

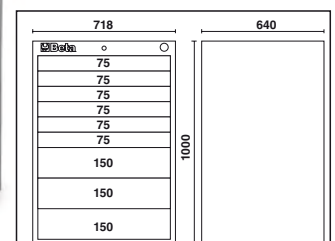
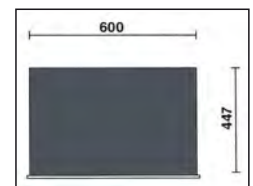

3500/P-M

worktop with perimeter edge for tool chest C35

3500/P-M

700x600 mm



1 035000505

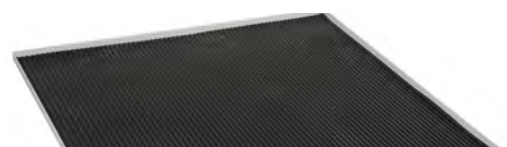



MOBILE ROLLER CAB C37

SOFT BUMPERS

- Drawers with ball bearing slides
- Sturdy multi-purpose worktop
- Quick release system made of aluminium, opening throughout length of drawer
- Tote-trays and holes for accommodating screwdrivers
- Four castors Ø 125 mm: 2 fixed and 2 steering (one with brake)
- Static load capacity: 1000 kg
- Corner bumpers throughout height of roller cab, to avoid damaging vehicles in garage
- Drawer bases protected by foamed rubber mats
- Front centralized safety lock
- Built-in side bottle and paper holders, adjustable in several positions

Available models:

- C37/6 (6 drawers)
- C37/7 (7 drawers)
- C37/8 (8 drawers)
- C37A/7 (7 drawers with anti-tilt system)

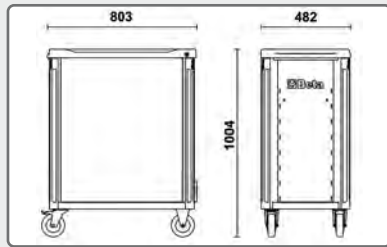
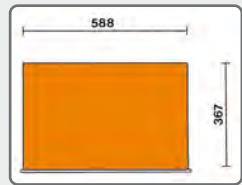

Available colours:

O	RAL 2011
G	RAL 7016
R	RAL 3000



Available accessories:

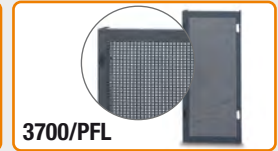

C37/7

mobile roller cab with 7 drawers

Main features:

- 7 drawers (588x367 mm) with ball bearing slides:
- 5 drawers 75 mm high
- 1 drawer 150 mm high
- 1 drawer 225 mm high

71 kg



C37/7-O



C37/7-G



C37/7-R



C37/7-O	1	037000071
C37/7-G	1	037000072
C37/7-R	1	037000073

h			max
75 mm			30 kg
150 mm			35 kg
225 mm			35 kg

C37/6

mobile roller cab
with 6 drawers

Main features:

- 6 drawers (588x367 mm) with ball bearing slides:
- 4 drawers 75 mm high
- 1 drawer 150 mm high
- 1 drawer 305 mm high

69 kg

		
C37/6-O	1	037000061
C37/6-G	1	037000062
C37/6-R	1	037000063

1000 kg



C37/6-G



C37/6-R



h	max
75 mm	30 kg
150 mm	35 kg
305 mm	40 kg



C37/8

mobile roller cab
with 8 drawers

Main features:

- 8 drawers (588x367 mm) with ball bearing slides:
- 6 drawers 75 mm high
- 2 drawers 150 mm high

73 kg

		
C37/8-O	1	037000081
C37/8-G	1	037000082
C37/8-R	1	037000083

1000 kg



C37/8-G



C37/8-R



h	max
75 mm	30 kg
150 mm	35 kg



C37A/7

mobile roller cab
with 7 drawers, with anti-tilt system

Main features:

- 7 drawers (588x367 mm), with ball bearing slides:
- 5 drawers 75 mm high
- 1 drawer 150 mm high
- 1 drawer 225 mm high

71 kg

		
C37A/7-O	1	037000271
C37A/7-G	1	037000272
C37A/7-R	1	037000273

1000 kg



C37A/7-G



C37A/7-R



h	max
75 mm	30 kg
150 mm	35 kg
225 mm	35 kg



3700/PLA

stainless steel worktop for mobile roller cab item C37, C37A

2,8 kg

3700/PLA 1 037000100



672x396x1,5 mm

3700/PLL

wood worktop for tool trolley C37, C37A

Can accommodate a vice (1599P/100, to be ordered separately)

3,9 kg

3700/PLL 1 037000101



672x396x28 mm

3700/PF

perforated panel with brackets for mobile roller cab item C37, C37A

50-hook GPS kit included

3,2 kg

3700/PF 1 037000102



626
650



3700/PFL

perforated side panel for mobile roller cab item C37, C37A

1,9 kg

3700/PFL 1 037000104



754
321

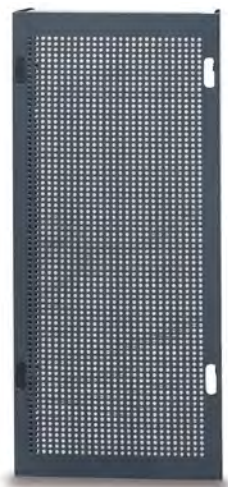

3700/PC

computer bracket for mobile roller cab item C37, C37A

3,1 kg

3700/PC 1 037000103

303
418



MOBILE ROLLER CAB C39

UPRIGHTS AND DRAWER FRONT MADE OF ALUMINIUM ALLOY

- + **STURDINESS**
- + **LIGHTWEIGHTNESS**

- Drawers with ball bearing slides
- Thermoplastic worktop, designed to support portable tool chest C39T
- Quick release system made of aluminium, opening throughout length of drawer
- Four castors Ø 125 mm: 2 fixed and 2 steering (one with brake)
- Static load capacity: 1200 kg
- Drawer bases protected by foamed rubber mats
- Front centralized safety lock
- Tote-trays and holes for accommodating screwdrivers
- Integrated side and rear bottle holders
- Integrated paper roll holder



Available colours:



O	RAL 2011
G	RAL 7016
R	RAL 3000

Available models:

- C39/6 (6 drawers)
- C39/7 (7 drawers)
- C39/8 (8 drawers)

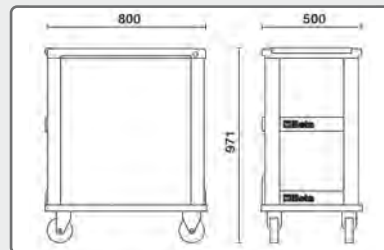
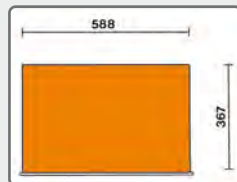

C39/7

roller cab
with seven drawers

Main features:

- Seven drawers (588x367 mm) with ball bearing slides:
 - 5 drawers, 70 mm high
 - 1 drawer, 140 mm high
 - 1 drawer, 210 mm high.

61 kg

1200 kg



C39-7/G



C39-7/R

C39-7/O

h	max
70 mm	30 kg
140 mm	35 kg
210 mm	35 kg



Model	Qty	Part No.
C39-7/O	1	039000001
C39-7/G	1	039000002
C39-7/R	1	039000003

C39/6

mobile roller cab with six drawers

Main features:

- Six drawers (588x367 mm) with ball bearing slides: 4 drawers, 70 mm high
- 1 drawer, 140 mm high
- 1 drawer, 280 mm high

59 kg

C39-6/O	1	039000031
C39-6/G	1	039000032
C39-6/R	1	039000033



h	max
70 mm	30 kg
140 mm	35 kg
280 mm	40 kg



C39/8

mobile roller cab with eight drawers

Main features:

- Eight drawers (588x367 mm) with ball bearing slides: 6 drawers, 70 mm high
- 2 drawers, 140 mm high

64 kg

C39-8/O	1	039000041
C39-8/G	1	039000042
C39-8/R	1	039000043



h	max
70 mm	30 kg
140 mm	35 kg



C39T

portable tool chest with four drawers

Main features:

- Four drawers (588x367 mm) with ball bearing slides: 4 drawers, 70 mm high
- Front centralized safety lock.
- Uprights and drawer front made of aluminium.

29 kg

C39T-O	1	039000101
C39T-G	1	039000102
C39T-R	1	039000103



29 kg

h	max
70 mm	30 kg

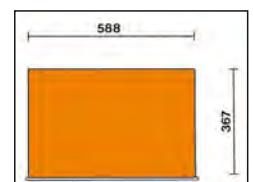
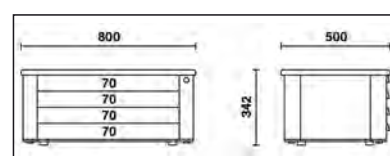

2400-COVER RSC24

nylon cover for mobile roller cabs RSC24 - C39



2400-COVER RSC24

1 024000910

2400-COVER RSC24AXL

nylon cover for mobile roller cabs RSC24AXL, RSC24L, RSC24L-CAB



2400-COVER RSC24AXL

1 024000930

Beta

C39SM

special mobile roller cab, Racing SM type

Specifications

- Multi-ply wood worktop
- 4 castors, Ø 125 mm
- 2 fixed and 2 steering (one with brake), with exposed covering
- Static load capacity: 1200 kg

7-drawer module

- 588x367 mm, with ball bearing slides:
- 6 drawers, 70 mm high
- 1 drawer, 240 mm high
- Drawer bases protected by foamed rubber mats
- Front centralized safety lock
- Opening system throughout length of drawer
- Drawer front made of aluminium

Service module

- Integrated wastepaper basket
- Paper roll compartment
- 1 large drawer (420x305x270 mm)

1200 kg



C39SM-G



C39SM-R



C39SM-O



492



h	max
70 mm	30 kg
240 mm	40 kg

125 kg

Model	RAL	Qty	Code
C39SM-O	RAL 2011	1	039390001
C39SM-G	RAL 7016	1	039390002
C39SM-R	RAL 3000	1	039390003

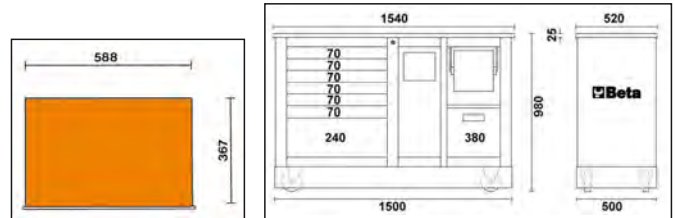

C39MD

special mobile roller cab, Racing MD type

Specifications

- Multi-ply wood worktop
- 4 castors, Ø 125 mm
- 2 fixed and 2 steering (one with brake), with exposed covering
- Static load capacity: 1200 kg

7-drawer module

- 588x367 mm, with ball bearing slides:
- 6 drawers, 70 mm high
- 1 drawer, 240 mm high
- Drawer bases protected by foamed rubber mats
- Front centralized safety lock
- Opening system throughout length of drawer
- Drawer front made of aluminium

2-drawer module

- 588x367x270 mm and 588x367x380 mm, with ball bearing slides
- Drawer bases protected by foamed rubber mats
- Front centralized lock
- Opening system throughout length of drawers
- Drawer front made of aluminium

1200 kg



C39MD-G



C39MD-R



C39MD-O



492

h	max
70 mm	30 kg
240 mm	40 kg

123 kg

Model	RAL	Qty	Code
C39MD-O	RAL 2011	1	039390101
C39MD-G	RAL 7016	1	039390102
C39MD-R	RAL 3000	1	039390103

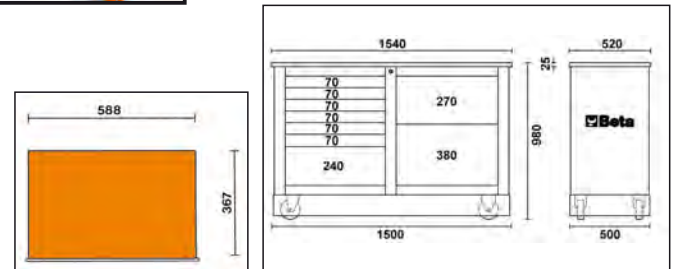

C41S

two-module tool trolley

Main features:

- Sheet metal frame and plastic tops, synonymous with remarkable sturdiness and reduced weight.
- 2 detachable modules:
 - 1 upper tool box,
 - 1 module with 2 drawers, 95 mm and 295 mm high respectively.
- Oversized castors (160 mm), built into frame for easy transport - for example, on steps.
- Side centralized lock
- for closing drawers of lower module.
- Drawers with ball bearing slides and double closing hook.
- Telescopic aluminium handle.
- Small tool holder built into upper tool box.
- Lower drawer with double ballbearing slide

Recommended assortments: 5940/SBK and 5915VU/5

16 kg

C41S

1 041000001

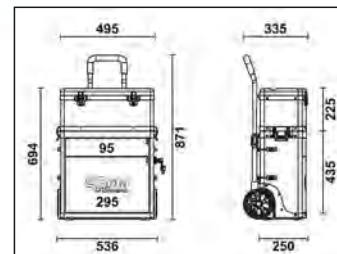
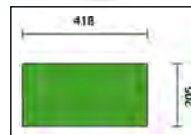

C41H

two-module tool trolley

Main features:

- Sheet metal frame and plastic tops, synonymous with remarkable sturdiness and reduced weight.
- 2 detachable modules:
 - 1 upper tool box,
 - 1 module with 2 drawers 95 mm in height,
 - 1 pull-out case made of plastic, 66 mm high, and 1 drawer 295 mm in height.
- Oversized castors (160 mm), built into frame for easy transport - for example, on steps.
- Side centralized lock for closing drawers of lower module.
- Drawers with ball bearing slides and double closing hook.
- Telescopic aluminium handle.
- Small tool holder built into upper tool box.
- Lower drawer with double ballbearing slide

Recommended assortments: 5941VU/M, 5940/SBK and 5915VU/5

* Colours available on request

21 kg

C41H-O	RAL 2011	1	041000002
C41H-N	RAL 9005	1	041000005
C41H-B	RAL 5002	1	041000006
C41H-R	RAL 3000	1	041000008
C41H-G	RAL 7016	1	041000010
C41H-Y	RAL 1023	1	041000012
C41H-W	RAL 9016	1	041000021
C41H-V	RAL 6016	1	041000024



C41H-O

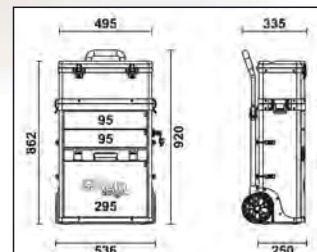
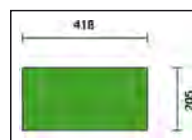

C41H/CE

tool chest
with removable partitions for small tools,
made from plastic material

1,3 kg

C41H/CE

1 041000916



C42H

three-module tool trolley

Main features:

- Sheet metal frame and plastic tops, synonymous with remarkable sturdiness and reduced weight.
- 3 detachable modules:
 - 1 upper tool box, 220 mm high
 - 1 central tool module, 180 mm high.
 - 1 lower tool module with castors, 330 mm high.
- Oversized castors (ø 160 mm).
- Telescopic handle, can be adjusted in 3 positions
- Quick module release system: easy, quick access to all tool compartments.
- Upper tool box with interior object compartment and 3 tool trays built into cover.
- Can be used with 2 modules.

Recommended assortments: 5940/SBK and 5915VU/5

14 kg

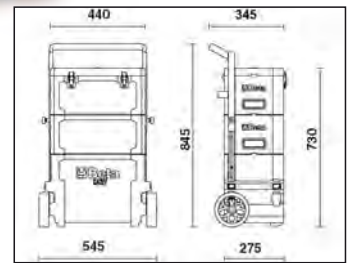

C42H

1 042000002



CX49-G

multi-purpose trolley

can be used as a mobile workstation for diagnostic tools, laptops, testers and battery chargers.

Specifications:

- Painted sheet metal frame: unparalleled firmness and sturdiness
- Ergonomic handle
- 2-level top
- Pull-out drawer for housing a mini keyboard
- 2 central shelves with adjustable position and 1 fixed low shelf
- 4 useful side cable reels made of plastic - 2 useful side containers
- 2 fixed rear castors Ø 160 mm
- 2 steering front castors Ø 100 mm (one with brake)
- Weight: 43 kg

CX49-G

1 049000102

1099 mm
460 mm
435 mm



CA49-G

multi-purpose trolley with door

can be used as a mobile workstation for diagnostic tools, laptops, testers and battery chargers.

Specifications:

- Painted sheet metal frame: unparalleled firmness and sturdiness
- Ergonomic handle
- 2-level top
- Pull-out drawer for housing a mini keyboard
- 1 shelf with adjustable position, 1 fixed shelf and door
- 4 useful side cable reels made of plastic
- 2 useful side containers
- 2 fixed rear castors Ø 160 mm
- 2 steering front castors Ø 100 mm (one with frame)
- Weight: 36.5 kg

CA49-G

1 049000112



1099 mm
460 mm
435 mm

4900-COVER C49

nylon cover for multi-purpose tool trolley item C49

4900-COVER C49

1 049000930



C48M

electric platform cart, with panels

Compact dimensions and versatile use make the C48M platform cart the ideal solution for handling heavy loads (boxes, containers, bulky objects, parts of equipment) in the power-assisted mode in complete safety, including in hardly accessible areas and in work environments which cannot be accessed via conventional forklift trucks.

This results in significantly reduced hazards for operators - e.g. musculoskeletal disorders caused by manual handling of loads.

Motorized platform, with 24V - 400W motor with 2x12V 33Ah battery supply and Curtis control card.

Loading floor made from sturdy steel, coated with non-slip rubber, with round tubular panels preventing objects from falling during transport.

The panels can be removed, to cater to individual transportation requirements.

The control console is equipped with the following:

- ignition key
- speed adjusting knob
- side butterfly handles for traction control
- intermittent beep, which is activated when moving in reverse
- battery charge indicator
- electric brake cut-out button
- emergency mushroom head button.

Fitted with 2 pneumatic traction wheels (Ø 260 mm) and 2 swivelling rubber wheels (Ø 150mm), electromagnetic brake and differential gear.

Supplied with an external battery charger, 220V/50Hz - V/A 24/12

FUNCTIONAL SPECIFICATIONS

Carrying capacity: 400 kg

Driving speed: 4-6 km/h (adjustable)

Battery life: 4 hours

Maximum permitted slope with a full load: 6%

Maximum permitted slope with 100 kg load: 18%

Safety devices:

Electronic brake

Buzzer

Anti-crushing guard

Battery charge indicator

Curtis control cart

TECHNICAL SPECIFICATIONS

Overall dimensions: 1280x630x1100h mm

Useful dimensions of loading platform with panels: 1150x570 mm

Useful dimensions of loading platform without panels: 1260x620 mm

Height of loading platform from floor: 320 mm

Height of battery compartment from floor: 65 mm

Weight with batteries: 140 kg

Beta
BRUTUS

400
kg

CE



1100
630
1280



140 kg

C48P

folding tool trolley

Main features:

- Loading platform made of reinforced polypropylene (PP), with non-slip coating and TPV inserts for corner protection
- Retractable handle for quick, compact storage
- Four non-marking castors, Ø 125 mm: 2 fixed and 2 steering with brakes
- Maximum capacity: 300 kg.
- Loading platform working width: 705 mm
- Loading platform depth: 480 mm
- Loading platform height: 200 mm



11 kg

C48P



048000030

C51

trolley

- 3 tops covered in antislip ribbed rubber
- Ergonomic handle
- Two fixing options for central worktop
- Four castors Ø 100 mm: 2 fixed and 2 steering (1 with brake)
- Static load capacity: 200 kg (distributed between 3 shelves)

21 kg

C51 O	RAL 2011	1	051000001
C51 G	RAL 7016	1	051000002
C51 R	RAL 3000	1	051000003

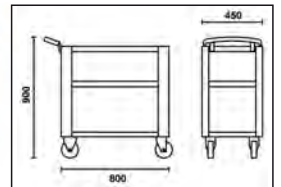
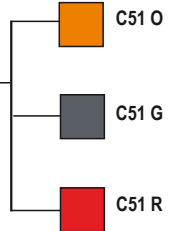

Beta



RSC51

service tool trolley with 3 drawers

Main features:

- ABS reinforced worktop, solid and sturdy
 - Multipurpose top with anti-fall edges and 8 holes for accommodating screwdrivers
 - 3 drawers (588x367 mm) with ball bearing slides, 70 mm high
 - Drawer bases protected by foamed rubber mats
 - Each drawer can accommodate up to 4 EVA foam or ABS thermoformed trays
 - Front centralized safety lock
 - Convenient side screwdriver holder included
 - Two built-in side spray can holders
 - Large lower shelf protected by an anti-oil and anti-petrol rubber mat
 - 4 castors, Ø 125 mm: 2 fixed castors and 2 swivel castors (one with brake)
- Static load capacity: 400 kg
 - Capacity of each drawer: 15 kg, evenly distributed

400 kg



RSC51-R



RSC51-A

RSC51-FO

38 kg



h	max
70 mm	15 kg

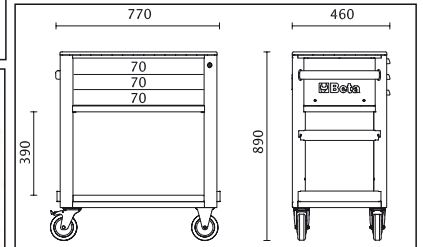
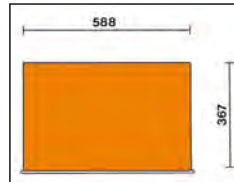

RSC51-FO	RAL 2011 - 7016	1	051000300
RSC51-R	RAL 3000 - 7016	1	051000303
RSC51-A	RAL 7016	1	051000307

2400 RSC24/MP

folding shelf for items RSC24, RSC24A, RSC51, RSC24AXLP/7, RSC24AXXL

- For use as additional worktop
- Worktop dimensions: 390x440 mm, protected by an anti-oil and anti-petrol rubber mat
- Load capacity: 20 kg

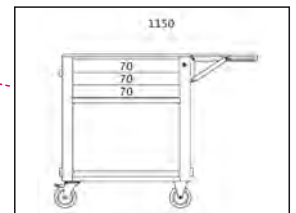

3,4 kg

2400 RSC24/MP		1	024004900
---------------	--	---	-----------



Beta



CP51

high-grade trolley

- 2 tops covered with rubber mats
- Ergonomic handle
- Four high-grade castors Ø 125 mm:
2 fixed and 2 steering with brake
- Static load capacity: 750 kg (shared by 2 tops)

37 kg

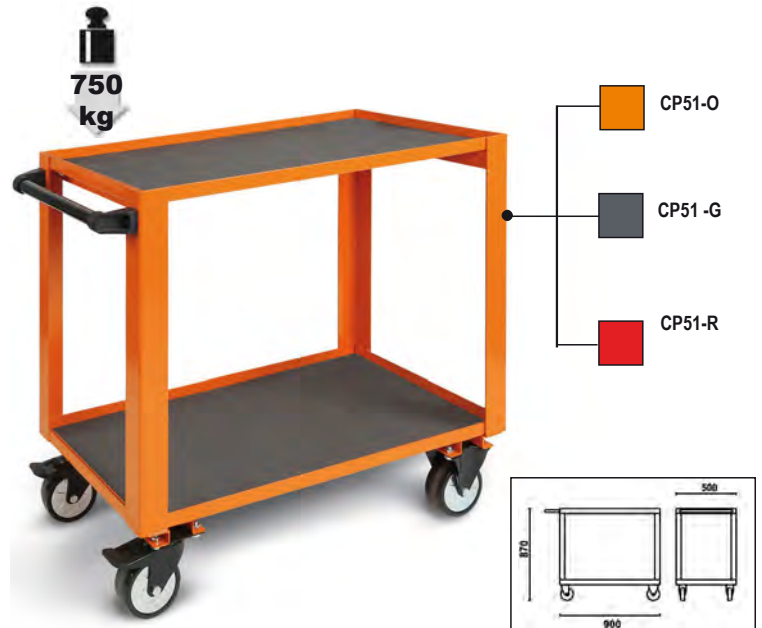

Model	Color	Weight	Capacity	Part No.
CP51 O	RAL 2011	1	750 kg	051000501
CP51 G	RAL 7016	1	750 kg	051000502
CP51 R	RAL 3000	1	750 kg	051000503

CB52

gearbox/transmission trolley
with liquid recovery system
Inclined plane and drain holes
allow liquids to be recovered in collection tank

Fitted with:

- 4 swivel castors, including 2 with brakes
- Tool drawer
- Pull-out liquid collection tank; capacity: 7 l
- 2 shelves

Features:

- Dimensions: 1200x640x870 mm
- Weight: 60 kg

60 kg



CB52-O

1 052000201

C56P O

folding workbench

Compact and easy to carry.

Worktop (800x500mm, 30 mm thick) made of MDF and galvanized sheet iron, for use on both sides.

Handle with rubber cover, for easy transportation.

Feet with nonslip cover.

Static load capacity: 250 kg

18 25 kg

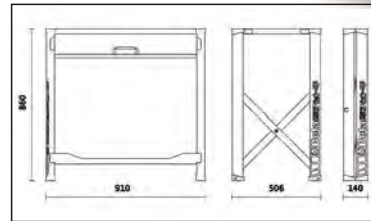

C56P O



1 056000011

C56PL O

folding workbench, Light version

Lightweight, compact, easy to carry.

Worktop (800x500mm) made galvanized sheet iron, for use on one side, protected by an anti-oil and anti-petrol rubber cover.

Handle with rubber cover, for easy transportation.

Feet with nonslip cover.

Static load capacity: 200 kg

18 18,5 kg

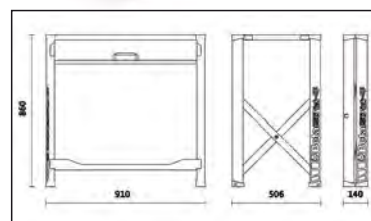

C56PL O



1 056000021

C54S

Cargo tool cabinets

These tool cabinets are designed according to detailed research and offer accurate, comfortable and rational solutions for end users.

Two perforated panels attached to the doors may be opened giving access to additional storage space.

Main features:

- 1 drawer, with slides.
- Easy tool layout according to users' needs.
- Easy wall mounting by means of two slots located at the back of the cabinet.
- Safety lock for both drawers and doors.
- Empty thermoformed tray for 1/2" sockets and accessories



C54S-O

37 kg

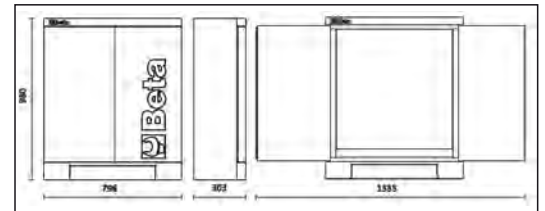

C54S-O

1 054000301

 **Beta**



C57SA

MasterCargo workbench

- Model with tool storage board (C57P) and one drawer cabinet.

Drawer cabinet: five drawers, 588x367 mm, 3 90 mm high, 1 180 mm and 1 280 mm high, with ball bearing slides. Can accommodate thermoformed trays. Centralized lock.

Panel tool holder with holes on back for wall mounting. Vertically operated aluminium shutter, with lock. Three removable perforated panels for supporting tools.

Multi-ply worktop, coated in plastic laminate with three holes for vice item 1599F/150 - 1599GI/150, to be ordered separately.



C57S/A-O

205 kg



C57S/A-G

C57S/A-R



h	max
90 mm	30 kg
180 mm	40 kg
280 mm	40 kg

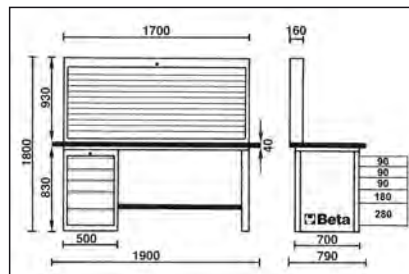

C57S/A-O	RAL 2011	1	057001005
C57S/A-G	RAL 7016	1	057001205
C57S/A-R	RAL 3000	1	057001405

C57SD

MasterCargo workbench

- Model with one drawer cabinet

Drawer cabinet: five drawers, 588x367 mm, 3 90 mm high, 1 180 mm and 1 280 mm high, with ball bearing slides. Can accommodate thermoformed trays. Centralized lock.

Multi-ply worktop, coated in plastic laminate with three holes for vice item 1599F/150 - 1599GI/150, to be ordered separately.



C57S/D-O



h	max
90 mm	30 kg
180 mm	40 kg
280 mm	40 kg

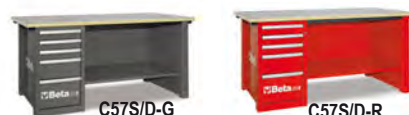

C57S/D-G

C57S/D-R

158 kg

C57S/D-O	RAL 2011	1	057001004
C57S/D-G	RAL 7016	1	057001204
C57S/D-R	RAL 3000	1	057001404

C57SB

MasterCargo workbench

- Model with tool storage board (C57P) and two drawer cabinets.

Drawer cabinet: five drawers, 588x367 mm, 3 90 mm high, 1 180 mm and 1 280 mm high, with ball bearing slides. Can accommodate thermoformed trays. Centralized lock.

Panel tool holder with holes on back for wall mounting. Vertically operated aluminium shutter, with lock. Three removable perforated panels for supporting tools.

Multi-ply wood worktop, coated in plastic laminate with three holes for vice item 1599F/150 - 1599GI/150, to be ordered separately.



C57S/B-O

243 kg



C57S/B-G



C57S/B-R



h	max
90 mm	30 kg
180 mm	40 kg
280 mm	40 kg

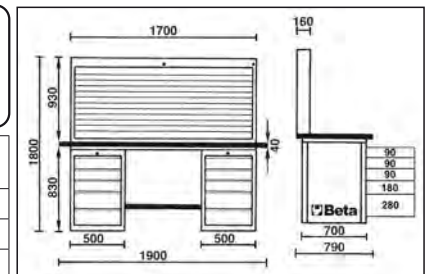

C57S/B-O	RAL 2011	1	057001006
C57S/B-G	RAL 7016	1	057001206
C57S/B-R	RAL 3000	1	057001406

C57SC

MasterCargo workbench

- Model with two drawer cabinets.

Drawer cabinet: five drawers, 588x367 mm, 3 90 mm high, 1 180 mm and 1 280 mm high, with ball bearing slides. Can accommodate thermoformed trays. Centralized lock.

Multi-ply wood worktop, coated in plastic laminate with three holes for vice item 1599F/150 - 1599GI/150, to be ordered separately.



C57S/C-O



h	max
90 mm	30 kg
180 mm	40 kg
280 mm	40 kg



C57S/C-G



C57S/C-R

196 kg

C57S/C-O	RAL 2011	1	057001003
C57S/C-G	RAL 7016	1	057001203
C57S/C-R	RAL 3000	1	057001403

C57SP

panel tool holder

Panel tool holder with two holes on back for wall mounting.
Aluminium shutter, vertically adjustable, with lock.
Three removable perforated panels for tool holding.

60 kg

C57SP-O	RAL 2011	1	057001020
C57SP-G	RAL 7016	1	057001220
C57SP-R	RAL 3000	1	057001420

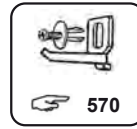

C57SP G

C57SP R

5700LAMP

MasterCargo workbench lamp

- Sturdy sheet metal frame comprising four elements; provided with screws for assembling the lamp.
- Lamp holder with 1120-Lumen LED strip, 4000K, 14W.
- Power supply 230V.
- Provided without wire.

9 kg

5700LAMP		1	057000005
----------	--	---	-----------



C58P

panel tool holder

- Panel tool holder with two holes on back for wall mounting.
- Security locked shutter made of painted aluminium.
- Two removable perforated panels for tool holding.

47,5 kg

C58P-O	RAL 2011	1	058000221
C58P-G	RAL 7016	1	058000222
C58P-R	RAL 3000	1	058000223



C58P-G



C58P-R



1360 mm

C58P-O

PV

wall tool panel

	LxA mm			
PV1	1000x920	10,2	1	088880010
PV1,5	1500x920	14,2	1	088880015



MODULAR WORKBENCHES

Beta has launched the new range of workbenches, MODULAR, designed to make it possible for professionals to configure their workplaces from scratch, adapting them to their individual needs.

The range comes in a wide choice of **preassembled combinations**; alternatively, you can fully **customize** your configuration, including the worktops, legs, mobile roller cabs and tool chests, tool wall systems and accessories.

The 75-cm-deep worktop means having a large, convenient, functional work surface available. It can be fitted with a vice, thereby allowing heavy-duty jobs to be carried out.

The new MODULAR range, designed according to the latest ergonomics studies, is enhanced by Beta's well-known sturdiness and quality, thereby standing out as an essential work partner.



Configure your workshop online



go to www.beta-tools.com

TOOL CHEST



TOOL WALL SYSTEMS



WORKTOPS



LEGS

C58BC-W1,6

simple workbench with wood worktop, 1.6 m long

Main features:

- Worktop (1,600x750 mm), made from multi-ply wood, 38 mm thick
- Steel frame with 4 supporting legs
- Holes for a vice (1599F/150 - 1599GI/150, to be ordered separately)
- Lower half-shelf for objects, 288x335 mm; thickness: 40 mm
- Can be fixed to floor
- Static load capacity: 1,000 kg, evenly distributed

Following accessories can be added:

- Perforated side panel C58PFL
- Anti-fall edge, 1,600 mm, C58BAC 1,6

61 kg

1000 kg

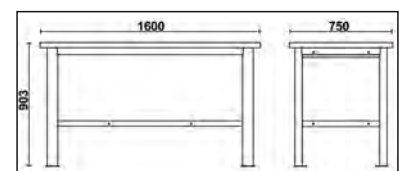

C58BC-W1,6

1 058000601

C58BC-X1,6

simple workbench with worktop made from stainless steel coated MDF, 1.6 m long

Main features:

- Worktop (1,600x750 mm) made from stainless steel coated MDF, 38 mm thick
- Steel frame with 4 supporting legs
- Holes for a vice (1599F/150 - 1599GI/150, to be ordered separately)
- Lower half-shelf for objects, 1,288x335 mm; thickness: 40 mm
- Can be fixed to floor
- Static load capacity: 1,000 kg, evenly distributed

Following accessories can be added:

- Perforated side panel C58PFL
- Anti-fall edge, 1,600 mm, C58BAC 1.6

74 kg

1000 kg

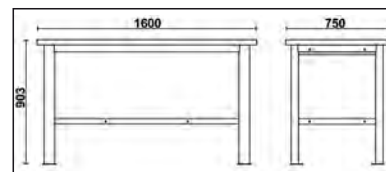

C58BC-X1,6

1 058000606

C58BC-W1,6 2C

workbench, 1.6 m long, with wood worktop and 2 drawers

Main features:

- Worktop (1,600x750 mm) made from multi-ply wood, 38 mm thick
- 2 drawers (367x588 mm) with ball bearing slides:
 - 1 drawer 70 mm high
 - 1 drawer 140 mm high.
- Drawer bases protected by foamed rubber mats
- Each drawer can accommodate up to 4 EVA foam or ABS thermoformed trays
- Front centralized lock
- Steel frame with 4 supporting legs
- Holes for a vice (1599F/150 - 1599GI/150, to be ordered separately)
- Lower half-shelf for objects, 1,288x335 mm; thickness: 40 mm
- Can be fixed to floor
- Static load capacity: 1,000 kg, evenly distributed

Following accessories can be added:

- Perforated side panel C58PFL
- Anti-fall edge, 1,600 mm, C58BAC 1.6

103,5 kg

1000 kg



C58BC-W1,6 2C/O



C58BC-W1,6 2C/A



h	max
70 mm	25 kg
140 mm	30 kg

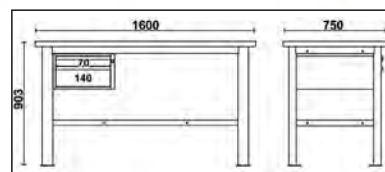

C58BC-W1,6 2C/O

1 058000611

C58BC-W1,6 2C/A

1 058000613

C58BC-W1,6 4C

workbench, 1.6 m long with wood worktop and 4 drawers

Main features:

- Worktop (1,600x750 mm) made from multi-ply wood, 38 mm thick
- 4 drawers (367x588 mm) with ball bearing slides:
 - 1 drawer 210 mm high
 - 3 drawers 70 mm high.
- Drawer bases protected by foamed rubber mats
- Each drawer can accommodate up to 4 EVA foam or ABS thermoformed trays
- Front centralized lock
- Steel frame with 4 supporting legs
- Holes for a vice (1599F/150 - 1599GI/150, to be ordered separately)
- Lower half-shelf for objects, 1,288x335 mm; thickness: 40 mm
- Can be fixed to floor
- Static load capacity: 1,000 kg, evenly distributed

Following accessories can be added:

- Perforated side panel C58PFL
- Anti-fall edge, 1,600 mm, C58BAC 1.6

1000 kg

RAL 2011



C58BC-W1,6 4C/O

82 kg

RAL 7016



C58BC-W1,6 4C/A



h	max
70 mm	25 kg
210 mm	30 kg

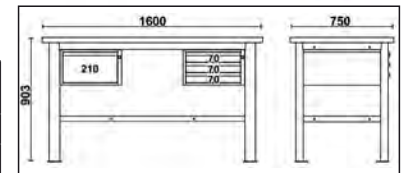

C58BC-W1,6 4C/O

1

058000612

C58BC-W1,6 4C/A

1

058000614

C58BC-W2,1

simple workbench with wood worktop, 2.1 m long

Main features:

- Worktop (2,100x750 mm) made from multi-ply wood, 38 mm thick
- Steel frame with 4 supporting legs
- Holes for a vice (1599F/150 - 1599GI/150, to be ordered separately)
- Lower half-shelf for objects, 1,788x335 mm; thickness: 40 mm
- Can be fixed to floor
- Static load capacity: 800 kg, evenly distributed

Following accessories can be added:

- Perforated side panel C58PFL
- Anti-fall edge, 2,100 mm, C58BAC 2.1

800 kg



70 kg

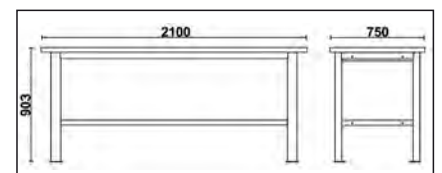

C58BC-W2,1

1

058000621

C58BC-X2,1

simple workbench with worktop made from stainless steel coated MDF, 2.1 m long

Main features:

- Worktop (2,100x750 mm) made from stainless steel coated MDF, 38 mm thick
- Steel frame with 4 supporting legs
- Holes for a vice (1599F/150 - 1599GI/150, to be ordered separately)
- Lower half-shelf for objects, 1,788x335 mm; thickness: 40 mm
- Can be fixed to floor
- Static load capacity: 1,000 kg, evenly distributed

Following accessories can be added:

- Perforated side panel C58PFL
- Anti-fall edge, 2,100 mm, C58BAC 2.1

93 kg

800 kg

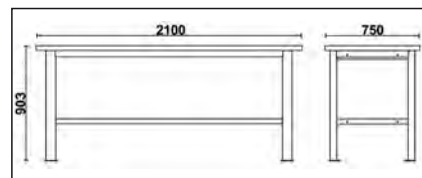

C58BC-X2,1

1 058000626

C58BC-W2,1 2C

workbench, 2.1 m long, with wood worktop and 2 drawers

Main features:

- Worktop (2,100x750 mm) made from multi-ply wood, 38 mm thick
- 2 drawers (367x588 mm) with ball bearing slides:
 - 1 drawer 70 mm high
 - 1 drawer 140 mm high.
- Drawer bases protected by foamed rubber mats
- Each drawer can accommodate up to 4 EVA foam or ABS thermoformed trays
- Front centralized lock
- Steel frame with 4 supporting legs
- Holes for a vice (1599F/150 - 1599GI/150, to be ordered separately)
- Lower half-shelf for objects, 1,788x335 mm; thickness: 40 mm
- Can be fixed to floor
- Static load capacity: 800 kg, evenly distributed

Following accessories can be added:

- Perforated side panel C58PFL
- Anti-fall edge, 2,100 mm, C58BAC 2.1

91 kg

800 kg



h	max
70 mm	25 kg
140 mm	30 kg

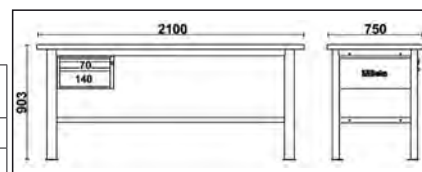

C58BC-W2,1 2C/O

1 058000631

C58BC-W2,1 2C/A

1 058000636

C58BC-W2,1 4C

workbench, 2.1 m long, with wood worktop and 4 drawers

Main features:

- Worktop (2,100x750 mm) made from multi-ply wood, 38 mm thick
- 4 drawers (367x588 mm) with ball bearing slides:
 - 2 drawers 70 mm high
 - 2 drawers 140 mm high.
- Drawer bases protected by foamed rubber mats
- Each drawer can accommodate up to 4 EVA foam or ABS thermoformed trays
- Front centralized lock
- Steel frame with 4 supporting legs
- Holes for a vice (1599F/150 - 1599GI/150, to be ordered separately)
- 2 lower half-shelves for objects, 1,788x335 mm; thickness: 40 mm
- Static load capacity: 800 kg, evenly distributed
- Can be fixed to floor

Following accessories can be added:

- Perforated side panel C58PFL
- Anti-fall edge, 2,100 mm, C58BAC 2.1

800
kg

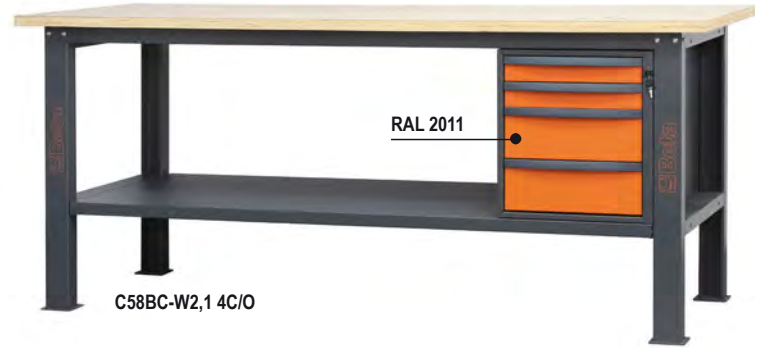

118 kg

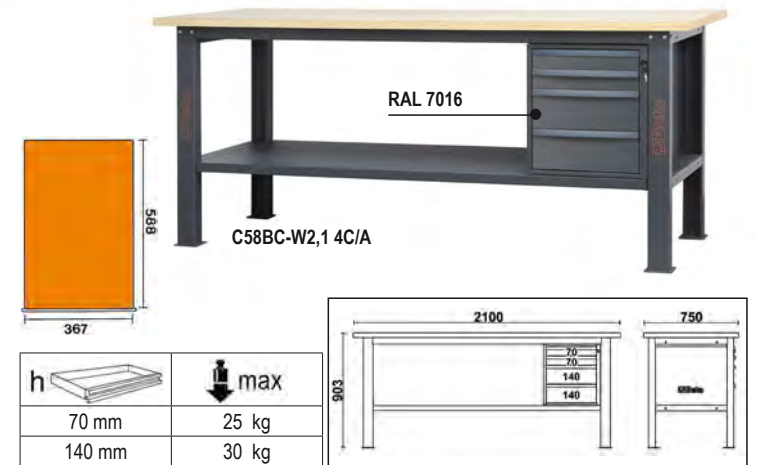

C58BC-W2,1 4C/O	1	058000632
C58BC-W2,1 4C/A	1	058000637

C58BC-W2,1 4CA

workbench, 2.1 m long, with wood worktop, 4 drawers and door module

Main features:

- Worktop (2,100x750 mm) made from multi-ply wood, 38 mm thick
- 4 drawers (367x588 mm) with ball bearing slides:
 - 2 drawers 70 mm high
 - 2 drawers 140 mm high.
- Drawer bases protected by foamed rubber mats
- Each drawer can accommodate up to 4 EVA foam or ABS thermoformed trays
- Front centralized lock
- 1 module with door and lock
- Steel frame with 4 supporting legs
- Holes for a vice (1599F/150 - 1599GI/150, to be ordered separately)
- 2 lower half-shelves for objects, 1,788x335 mm; thickness: 40 mm
- Static load capacity: 800 kg, evenly distributed
- Can be fixed to floor

Following accessories can be added:

- Perforated side panel C58PFL
- Anti-fall edge, 2,100 mm, C58BAC 2.1

800
kg



133 kg

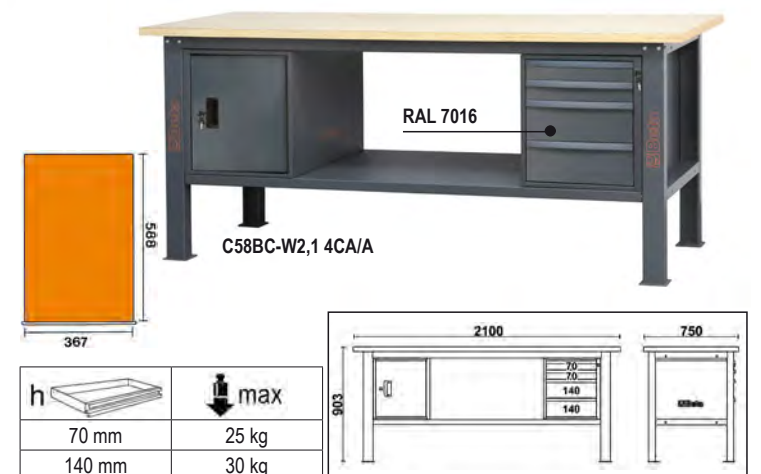

C58BC-W2,1 4CA/O	1	058000633
C58BC-W2,1 4CA/A	1	058000638

C58BC-W2,1 6CA

workbench, 2.1 m long, with wood worktop, 6 drawers and door module

Main features:

- Worktop (2,100x750 mm) made from multi-ply wood, 38 mm thick
- 6 drawers (367x588 mm) with ball bearing slides:
 - 1 drawer 210 mm high
 - 4 drawers 70 mm high
 - 1 drawer 140 mm high.
- Drawer bases protected by foamed rubber mats
- Each drawer can accommodate up to 4 EVA foam or ABS thermoformed trays
- Front centralized lock
- 1 module with door and lock
- Steel frame with 4 supporting legs
- Holes for a vice (1599F/150 - 1599GI/150, to be ordered separately)
- 2 lower half-shelves for objects, 1,788x335 mm; thickness: 40 mm
- Static load capacity: 800 kg, evenly distributed
- Can be fixed to floor

Following accessories can be added:

- Perforated side panel C58PFL
- Anti-fall edge, 2,100 mm, C58BAC 2.1

162 kg

C58BC-W2,1 6CA/O	1	058000634
C58BC-W2,1 6CA/A	1	058000639

800 kg



C58BC-W2,1 6CA/O



C58BC-W2,1 6CA/A



h	max
70 mm	25 kg
140 mm	30 kg
210 mm	30 kg

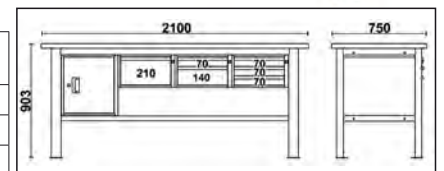

C58BC-W2,1 8CA

workbench, 2.1 m long, with wood worktop, 8 drawers and door module

Main features:

- Worktop (2,100x750 mm) made from multi-ply wood, 38 mm thick
- 8 drawers (367x588 mm) with ball bearing slides:
 - 5 drawers 70 mm high
 - 2 drawers 140 mm high
 - 1 drawer 210 mm high.
- Drawer bases protected by foamed rubber mats
- Each drawer can accommodate up to 4 EVA foam or ABS thermoformed trays
- Front centralized lock
- 1 module with door and lock
- Steel frame with 4 supporting legs
- Holes for a vice (1599F/150 - 1599GI/150, to be ordered separately)
- 2 lower half-shelves for objects, 1,788x335 mm; thickness: 40 mm
- Static load capacity: 800 kg, evenly distributed
- Can be fixed to floor

Following accessories can be added:

- Perforated side panel C58PFL
- Anti-fall edge, 2,100 mm, C58BAC 2.1

174 kg

C58BC-W2,1 8CA/O	1	058000635
C58BC-W2,1 8CA/A	1	058000640

800 kg



C58BC-W2,1 8CA/O



C58BC-W2,1 8CA/A



h	max
70 mm	25 kg
140 mm	30 kg
210 mm	30 kg

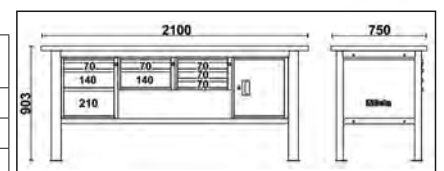

C58BC-X2,1 4C

workbench, 2.1 m long, with worktop made from stainless steel coated MDF and 4 drawers

Main features:

- Worktop (2,100x750 mm) made from stainless steel coated MDF, 38 mm thick
- 4 drawers (367x588 mm) with ball bearing slides:
 - 2 drawers 70 mm high
 - 2 drawers 140 mm high.
- Drawer bases protected by foamed rubber mats
- Each drawer can accommodate up to 4 EVA foam or ABS thermoformed trays
- Front centralized lock
- Steel frame with 4 supporting legs
- Holes for a vice (1599F/150 - 1599GI/150, to be ordered separately)
- 2 lower half-shelves for objects, 1,788x335 mm; thickness: 40 mm
- Static load capacity: 800 kg, evenly distributed
- Can be fixed to floor

Following accessories can be added:

- Perforated side panel C58PFL
- Anti-fall edge, 2,100 mm, C58BAC 2.1

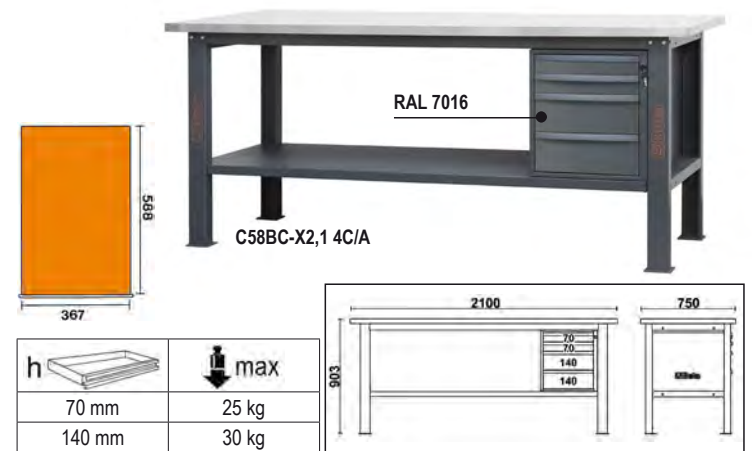

C58BC-X2,1 4C/O	1	058000623
C58BC-X2,1 4C/A	1	058000627

C58BC-X2,1 4CA

workbench, 2.1 m long, with worktop made from stainless steel coated MDF, 4 drawers and door module

Main features:

- Worktop (2,100x750 mm) made from stainless steel coated MDF, 38 mm thick
- 4 drawers (367x588 mm) with ball bearing slides:
 - 2 drawers 70 mm high
 - 2 drawers 140 mm high.
- Drawer bases protected by foamed rubber mats
- Each drawer can accommodate up to 4 EVA foam or ABS thermoformed trays
- Front centralized lock
- 1 module with door and lock
- Steel frame with 4 supporting legs
- Holes for a vice (1599F/150 - 1599GI/150, to be ordered separately)
- 2 lower half-shelves for objects, 1,788x335 mm; thickness: 40 mm
- Static load capacity: 800 kg, evenly distributed
- Can be fixed to floor

Following accessories can be added:

- Perforated side panel C58PFL
- Anti-fall edge, 2,100 mm, C58BAC 2.1

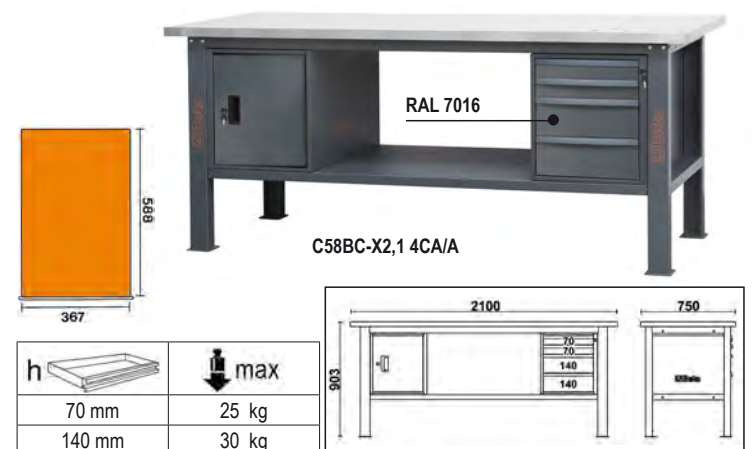
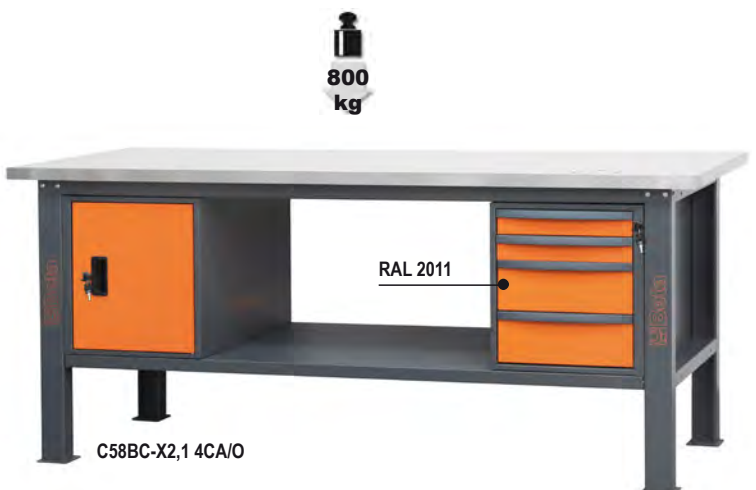

C58BC-X2,1 4CA/O	1	058000624
C58BC-X2,1 4CA/A	1	058000628

C58BC-X2,1 8CA

workbench, 2.1 m long, with worktop made from stainless steel coated MDF, 8 drawers, 8 drawers and door module

Main features:

- Worktop (2,100x750 mm) made from stainless steel coated MDF, 38 mm thick
- 8 drawers (367x588 mm) with ball bearing slides:
 - 5 drawers 70 mm high
 - 2 drawers 140 mm high
 - 1 drawer 210 mm high.
- Drawer bases protected by foamed rubber mats
- Each drawer can accommodate up to 4 EVA foam or ABS thermoformed trays
- Front centralized lock
- 1 module with door and lock
- Steel frame with 2 supporting legs
- Holes for a vice (1599F/150 - 1599GI/150, to be ordered separately)
- 2 lower half-shelves for objects, 1,788x335 mm; thickness: 40 mm
- Static load capacity: 800 kg, evenly distributed
- Can be fixed to floor

Following accessories can be added:

- Perforated side panel C58PFL
- Anti-fall edge, 2,100 mm, C58BAC 2.1

197 kg

C58BC-X2,1 8CA/O	1	058000625
C58BC-X2,1 8CA/A	1	058000629



h	max
70 mm	25 kg
140 mm	30 kg
210 mm	30 kg

C58PLT-W 1,6

worktop (1,600x750 mm) made from multi-ply wood, for modular workbenches C58BC

- Thickness: 38 mm
- Holes for a vice (1599F/150 - 1599GI/150, to be ordered separately)

35,5 kg

C58PLT-W 1,6	1	058000641
--------------	---	-----------



C58PLT-X 1,6

worktop (1,600x750 mm) made from stainless steel coated MDF, for modular workbenches C58BC

- Thickness: 38 mm
- Holes for a vice (1599F/150 - 1599GI/150, to be ordered separately)

48,5 kg

C58PLT-X 1,6	1	058000646
--------------	---	-----------



C58PLT-W 2,1

worktop (2,100x750 mm) made from multi-ply wood, for modular workbenches C58BC

- Thickness: 38 mm
- Holes for a vice (1599F/150 - 1599GI/150, to be ordered separately)

41 kg

C58PLT-W 2,1	1	058000651
--------------	---	-----------



C58PLT-X 2,1

worktop (2,100x750 mm) made from stainless steel coated MDF, for modular workbenches C58BC

- Thickness: 38 mm
- Holes for a vice (1599F/150 - 1599GI/150, to be ordered separately)



63,5 kg

C58PLT-X 2,1

1 058000656

C58GF

fixed height leg, for modular workbenches C58BC

- Sturdy sheet metal frame, with holes for fixing shelves
- Height: 866 mm
- Can be fixed to floor
- Colour: anthracite grey RAL7016
- Carrying capacity: 400 kg

8 kg



C58GF

1 058000660

C58GT

vertically adjustable leg, for modular workbenches C58BC

Vertically adjustable height allows individual requirements to be satisfied, thereby translating into optimally ergonomic workbenches.

- Sturdy sheet metal frame, with holes for fixing shelves
- Height: 715 ÷ 1,065 mm; hole pitch: 25 mm
- Can be fixed to floor
- Colour: anthracite grey RAL7016
- Carrying capacity: 400 kg

10 kg



C58GT

1 058000661

C58GRGM

leg with steering castors and handle, for modular workbenches C58BC

- Sturdy sheet metal frame, with holes for fixing shelves
- 2 steering castors, Ø 125 mm, with brakes
- Side handle for convenient carrying of workbench
- Overall height: 824 mm, including castor
- Colour: anthracite grey RAL7016
- Carrying capacity: 400 kg

9,5 kg



C58GRGM

1 058000662

C58GRF

leg with fixed castors, for modular workbenches C58BC

- Sturdy sheet metal frame, with holes for fixing shelves
- 2 fixed castors, Ø 125 mm
- Overall height: 824 mm, including castor
- Colour: anthracite grey RAL7016
- Carrying capacity: 400 kg

8,5 kg



C58GRF

1 058000663

C58CS 1C

tool chest, 257 mm high, with 1 drawer, for modular workbenches C58BC

- 1 fully removable drawer (367x588 mm), with ball bearing slides, 210 mm high
- Front centralized safety lock
- Drawer base protected by foamed rubber mat
- Each drawer can accommodate up to 4 EVA foam or ABS thermoformed trays



18,5 kg

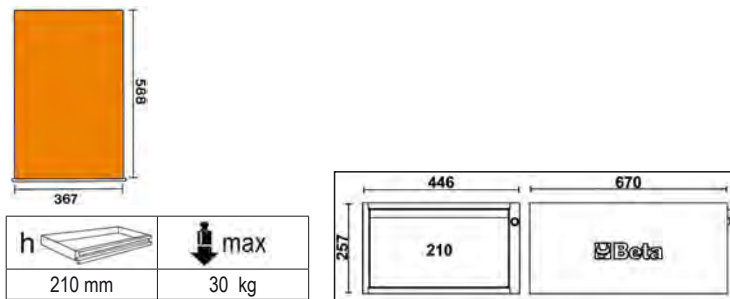

C58CS/O 1C	1	058000671
C58CS/A 1C	1	058000674

C58CS 2C

tool chest, 257 mm high, with 2 drawers, for modular workbenches C58BC

- 2 fully removable drawers (367x588 mm), with ball bearing slides:

1 drawer 70 mm high

1 drawer 140 mm high

- Front centralized safety lock

- Drawer bases protected by foamed rubber mats

- Each drawer can accommodate up to 4 EVA foam or ABS thermoformed trays



21 kg

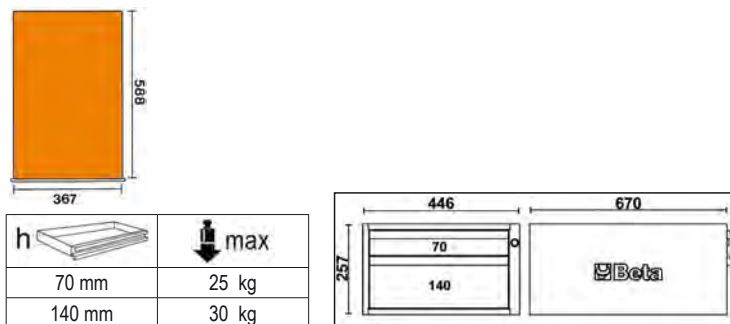

C58CS/O 2C	1	058000672
C58CS/A 2C	1	058000675

C58CS 3C

tool chest, 257 mm high, with 3 drawers, for modular workbenches C58BC

- 3 fully removable drawers (367x588 mm), with ball bearing slides, 70 mm high
- Front centralized safety lock
- Drawer bases protected by foamed rubber mats
- Each drawer can accommodate up to 4 EVA foam or ABS thermoformed trays



24 kg

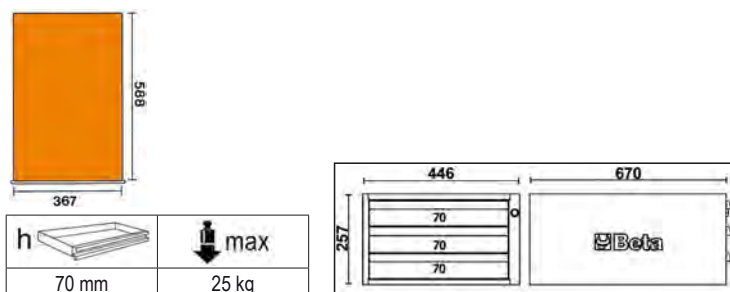

C58CS/O 3C	1	058000673
C58CS/A 3C	1	058000676

C58MA

module, 479 mm high, with door, for modular workbenches C58BC

- Front safety lock
- Sheet metal door can be installed with right or left opening
- Usable interior dimensions: 440x640x447 mm

15 kg

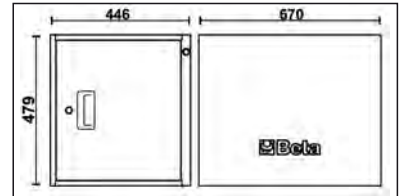

C58MA/O	1	058000680
C58MA/A	1	058000681

C58CSH 3C

tool chest, 479 mm high, with 3 drawers, for modular workbenches C58BC

- 3 fully removable drawers (367x588 mm), with ball bearing slides:
 - 1 drawer 70 mm high
 - 1 drawer 140 mm high
 - 1 drawer 210 mm high
- Front centralized safety lock
- Drawer bases protected by foamed rubber mats
- Each drawer can accommodate up to 4 EVA foam or ABS thermoformed trays

31 kg

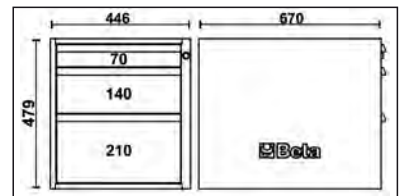

h	max
70 mm	25 kg
140 mm	30 kg
210 mm	30 kg

C58CSH/O 3C	1	058000682
C58CSH/A 3C	1	058000686

C58CSH 4C

tool chest, 479 mm high, with 4 drawers, for modular workbenches C58BC

- 4 fully removable drawers (367x588 mm), with ball bearing slides:
 - 2 drawers 70 mm high
 - 2 drawers 140 mm high
- Front centralized safety lock
- Drawer bases protected by foamed rubber mats
- Each drawer can accommodate up to 4 EVA foam or ABS thermoformed trays

35 kg

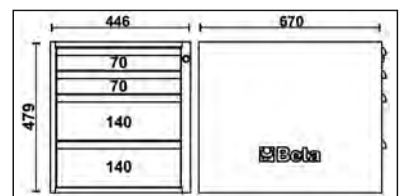

h	max
70 mm	25 kg
140 mm	30 kg

C58CSH/O 4C	1	058000683
C58CSH/A 4C	1	058000687

C58CSH 5C

tool chest, 479 mm high, with 5 drawers, for modular workbenches C58BC

- 5 fully removable drawers (367x588 mm), with ball bearing slides:
 - 4 drawers 70 mm high
 - 1 drawer 140 mm high
- Front centralized safety lock
- Drawer bases protected by foamed rubber mats
- Each drawer can accommodate up to 4 EVA foam or ABS thermoformed trays

37,5 kg



RAL 2011

C58CSH/O 5C

RAL 7016

C58CSH/A 5C

C58CSH/O 5C	1	058000684
C58CSH/A 5C	1	058000688

h	max
70 mm	25 kg
140 mm	30kg

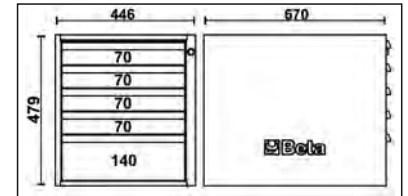

C58CSH 6C

tool chest, 479 mm high, with 6 drawers, for modular workbenches C58BC

- 6 fully removable drawers (367x588 mm), with ball bearing slides, 70 mm high
- Front centralized safety lock
- Drawer bases protected by foamed rubber mats
- Each drawer can accommodate up to 4 EVA foam or ABS thermoformed trays

40 kg



RAL 2011

C58CSH/O 6C

RAL 7016

C58CSH/A 6C

C58CSH/O 6C	1	058000685
C58CSH/A 6C	1	058000689

h	max
70 mm	25 kg

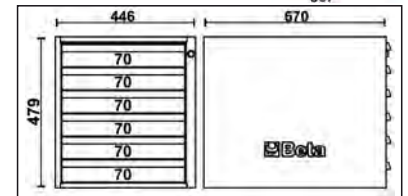

C58K/2PF-1,6M

kit of 2 perforated tool panels with frames, for modular workbenches C58BC, 1.6 m long

Kit contents:

- 3 supporting brackets
- 3 400-mm uprights
- 2 765-mm supports; can accommodate 1 19" rack multi-socket (not included)
- 2 perforated tool panels, 765x25x400 mm

14,4 kg

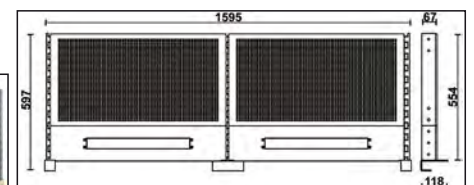
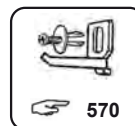

C58K/2PF-1,6M	1	058000802
---------------	---	-----------

C58K/4PF-1,6M

kit of 4 perforated tool panels with frames, for modular workbenches
C58BC, 1.6 m long

Kit contents:

- 3 supporting brackets
- 6 400-mm uprights
- 2 765-mm supports; can accommodate 1 19" rack multi-socket (not included)
- 4 perforated tool panels, 765x400 mm

23,9 kg

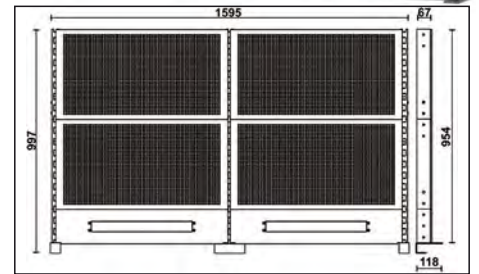
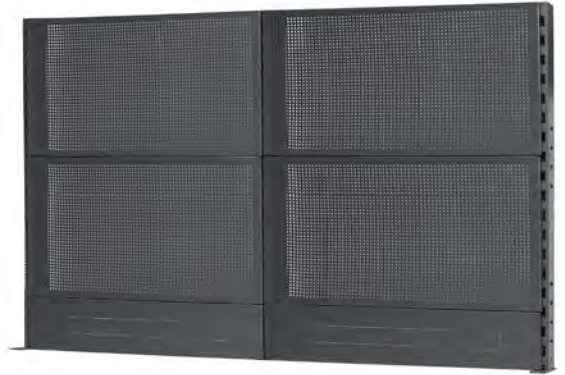
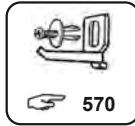

C58K/4PF-1,6M

1 058000804

C58K/2PF-2,1M

kit of 2 perforated tool panels with frames, for modular workbenches
C58BC, 2.1 m long

Kit contents:

- 3 supporting brackets
- 3 400-mm uprights
- 2 1,015-mm supports; can accommodate 1 19" rack multi-socket (not included)
- 2 perforated tool panels, 1,015x25x400 mm

17 kg

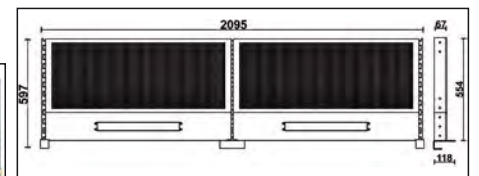
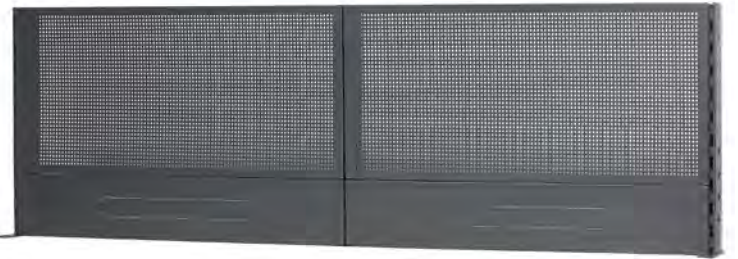

C58K/2PF-2,1M

1 058000812

C58K/4PF-2,1M

kit of 4 perforated tool panels with frames, for modular workbenches
C58BC, 2.1 m long

Kit contents:

- 3 supporting brackets
- 6 400-mm uprights
- 2 1,015-mm supports; can accommodate 1 19" rack multi-socket (not included)
- 4 perforated tool panels, 1,015x25x400 mm

28,2 kg

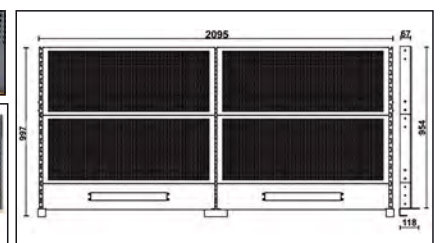
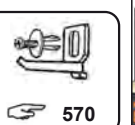

C58K/4PF-2,1M

1 058000814

C58SP 1,6

supporting half-shelf, for modular workbenches C58BC, 1.6 m long

- Thickness: 40 mm
- Fixing material included

9,7 kg



C58SP 1,6

1 058000690

C58SP 2,1

supporting half-shelf, for modular workbenches C58BC, 2.1 m long

- Thickness: 40 mm
- Fixing material included

13,3 kg



C58SP 2,1

1 058000691

C58BAC 1,6

anti-fall edge for modular workbenches C58BC, 1.6 m long

- Can accommodate 2 electrical outlets and 1 19" rack multi-socket (not included)
- Dimensions: 1,600x55x120 mm

4,5 kg



C58BAC 1,6

1 058000692

C58BAC 2,1

anti-fall edge for modular workbenches C58BC, 2.1 m long

- Can accommodate 2 electrical outlets and 1 19" rack multi-socket (not included)
- Dimensions: 2.100x55x120 mm

5,8 kg



C58BAC 2,1

1 058000693

C58PFL

perforated side panel for modular workbenches C58BC

- Dimensions: 560x25x545 mm
- Fixing material included

1,8 kg



C58PFL

1 058000696

C58MP-0,8M

shelf for modular workbenches C58BC, 1,6 m long

- Dimensions: 774x335 mm
- Designed for application of aluminium profiles with LED strip item 5000 RSC50 2.0/PLEDC or 5000 RSC50 2.0/PLED-ST (to be ordered separately), to light under-workbench modules

3,5 kg



C58MP-0,8M

1 058000840

C58MP-1M

shelf for modular workbenches C58BC, 2,1 m long

- Dimensions: 1,024x335 mm
- Designed for application of aluminium profiles with LED strip item 5000 RSC50 2.0/PLEDC or 5000 RSC50 2.0/PLED-ST (to be ordered separately), to light under-workbench modules

4,5 kg



C58MP-1M

1 058000841

C58BLP-1,6M

LED lamp track, for modular workbenches C58BC, 1,6 m long

- Frame length: 1,550 mm
- Can be supplied with 1 LED lamp item C58PLED-150 (to be ordered separately)

5,2 kg



C58BLP-1,6M

1 058000850

C58BLP-1M

LED lamp track, for modular workbenches, C58BC 2,1 m long

- Frame length: 1,024 mm
- Can be supplied with 1 LED lamp item C58PLED-90 (to be ordered separately) • To complete the set-up of the 2,1 m bench, 2 units must be ordered

3,8 kg



C58BLP-1M

1 058000851

C58PLED-150

LED lamp for modular workbenches C58BC, 1,6 m long

- Dimensions: 1,500x25x78 mm
- Power: 48W
- Brightness: 4,320 lumens
- Light temperature: 6400k
- Light beam: 180°
- Degree of protection: IP20
- Average life: >20,000 hours
- Operating temperature: -10 °C ÷ +45 °C
- Operating voltage: 220-240AC, 50/60 Hz
- Supplied with fixing clips

540 g



C58PLED-150

1 058000860

C58PLED-90

LED lamp for modular workbenches C58BC, 2.1 m long

CE

- Dimensions: 900x23x75 mm
- Power: 24W
- Brightness: 2,200 lumens
- Light temperature: 6400k
- Light beam: 180°
- Degree of protection: IP20
- Average life: >20,000 hours
- Operating temperature: -10 °C ÷ +45 °C
- Operating voltage: 220-240AC, 50/60 Hz
- Supplied with fixing clips



340 g

C58PLED-90

1 058000861

C56

workbench

- Worktop made of painted sheet metal with external edge
- Steel frame with 6 supporting legs
- Static load capacity: 1200 kg
- Matches panel toolholder C57P; cannot be fixed to worktop
- Two drawers with lock
- Can be fixed to floor

82 kg



C56-O	RAL 2011	1	056000201
C56-G	RAL 7016	1	056000202
C56-R	RAL 3000	1	056000203

C56W

workbench with wood top

- Multi-ply wood worktop with holes for a vice (1599F/125 - 1599GI/125, to be ordered separately).
- Steel frame with 6 supporting legs
- Static load capacity: 1,200 kg
- Matches panel tool holder C57P; cannot be fixed to worktop.
- Two drawers with locks.
- Can be fixed to floor.

86 kg



C56W-O	RAL 2011	1	056000251
C56W-G	RAL 7016	1	056000252
C56W-R	RAL 3000	1	056000253

C59A

"Endurance" workbench with 1 cab with six drawers

Main features:

- Worktop made from multi-ply wood with holes for vice item 1599F/125 - 1599GI/125 (to be ordered separately).
- 6 drawers (588x367 mm) with ball bearing slides:
 - 4 drawers, 70 mm high
 - 1 drawer, 140 mm high
 - 1 drawer, 280 mm high.
- Drawers protected by foamed rubber mats.
- Hard-wearing nylon drawer front.
- Roller cabs can accommodate thermoformed trays.
- Front centralized safety lock.
- Lower object shelf.
- Can be fitted with paper roll holder (2400 RSC24/PC) and bottle holder (2400 RSC24/PF-), to be ordered separately.

115 kg



C59A-O



1500 kg



C59A-A



C59A-R

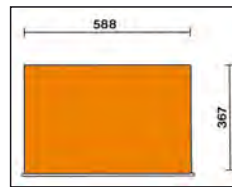

h	max
70 mm	25 kg
140 mm	30 kg
280 mm	35 kg

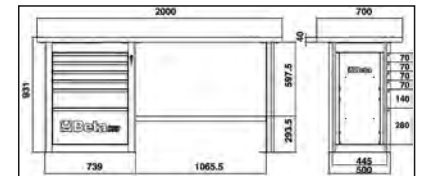

C59A-O	RAL 2011 - 7016	1	059000011
C59A-A	RAL 7016	1	059000031
C59A-R	RAL 3000 - 7016	1	059000051

C59B

"Endurance" workbench with 2 cabs with six drawers

Main features:

- Worktop made from multi-ply wood with holes for vice item 1599F/125 - 1599GI/125 (to be ordered separately).
- 12 drawers (588x367 mm) with ball bearing slides:
 - 8 drawers, 70 mm high
 - 2 drawers, 140 mm high
 - 2 drawers, 280 mm high.
- Drawers protected by foamed rubber mats.
- Can accommodate thermoformed trays.
- Front centralized safety lock.
- Lower object shelf.
- Can be fitted with paper roll holder (2400 RSC24/PC) and bottle holder (2400 RSC24/PF-), to be ordered separately.

155 kg

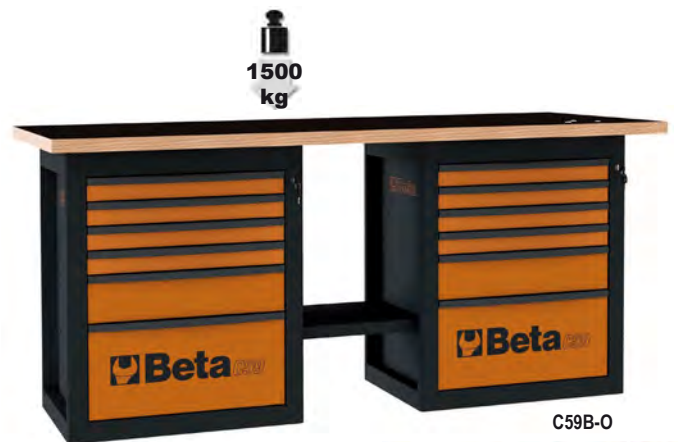

1500 kg

C59B-O



C59B-A



C59B-R

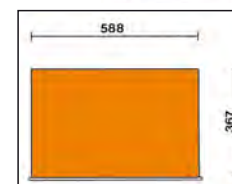

h	max
70 mm	25 kg
140 mm	30 kg
280 mm	35 kg

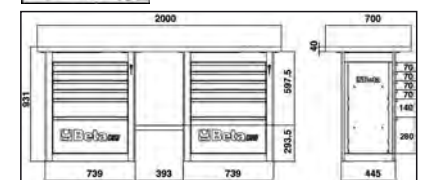

C59B-O	RAL 2011 - 7016	1	059000012
C59B-R	RAL 3000 - 7016	1	059000052
C59B-A	RAL 7016	1	059000032

"Endurance" workbench with 1 cab with six drawers, short model

Main features:

- Worktop made from multi-ply wood with holes for vice item 1599F/125 - 1599GI/125 (to be ordered separately).
- 6 drawers (588x367 mm) with ball bearing slides:
 - 4 drawers, 70 mm high
 - 1 drawer, 140 mm high
 - 1 drawer, 280 mm high.
- Drawers protected by foamed rubber mats.
- Can accommodate thermoformed trays.
- Front centralized safety lock.
- Lower object shelf.
- Can be fitted with paper roller holder (2400 RSC24/PC) and bottle holder (2400 RSC24/PF-), to be ordered separately.

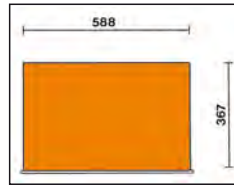
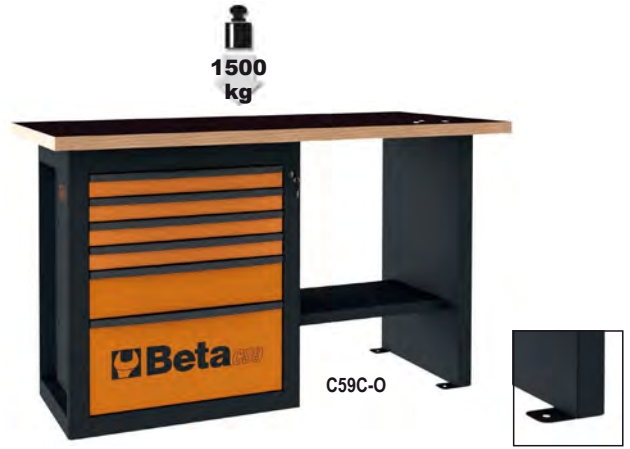

h	max
70 mm	25 kg
140 mm	30 kg
280 mm	35 kg

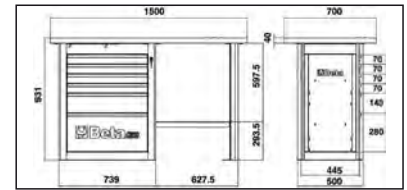

105 kg

C59C-O	RAL 2011 - 7016	1	059000013
C59C-R	RAL 3000 - 7016	1	059000053
C59C-A	RAL 7016	1	059000033

